



# SPARE PARTS LIST

## DEMOLITION ROBOTS

DXR140, Valid for machine 1 to 254,  
2019-06

**A** DXR 140  
SUPPORT LEGS

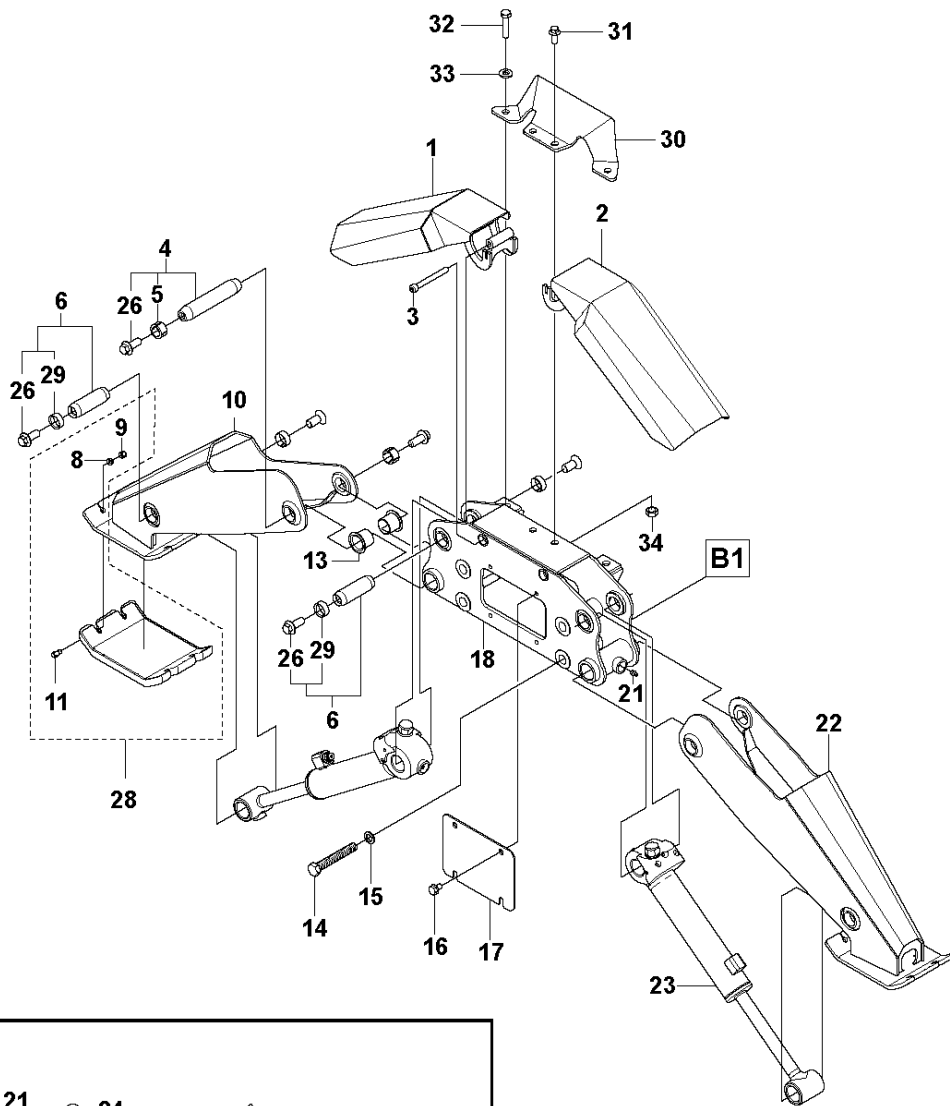
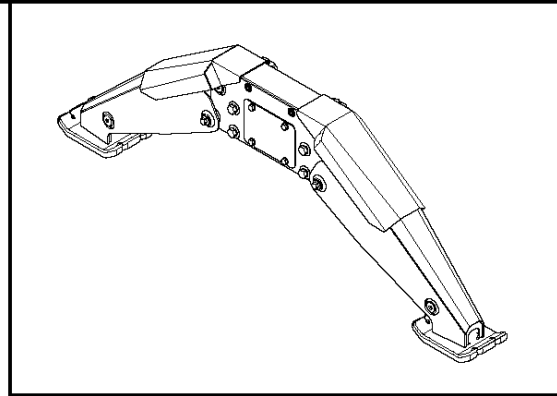

**23**

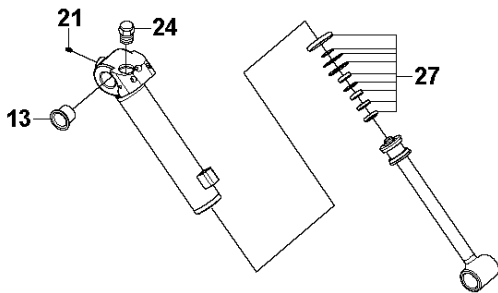

## SUPPORT LEGS

DXR140, Valid for machine 1 to 254, 2019-06

Ref	Part No	Description	Remark	QTY	KIT
1	575 43 35-01	COVER		2	
2	575 43 36-01	COVER		2	
3	725 55 09-55	SCREW IHSCM		4	
4	525 80 38-01	SHAFT		4	
5	529 29 92-01	SLEEVE		8	4
6	586 11 98-01	SHAFT		4	
8	522 67 17-01	WASHER		16	28
9	522 66 95-01	LOCK NUT		16	28
10	529 27 36-01	SUPPORT LEG		2	
11	522 66 72-02	SCREW IHSCM		16	28
13	525 80 24-01	BEARING BUSH		8	23
14	575 29 32-01	SCREW EHHM		8	
15	522 67 19-01	WASHER		8	
16	575 65 97-01	SCREW EHHFM		4	
17	575 65 98-01	PLATE		1	
18	575 48 77-01	BRACKET	REAR	1	
18	575 48 75-01	BRACKET	FRONT	1	
21	504 89 53-01	LUBRICATION NIPPLE		2	23
22	529 27 35-01	SUPPORT LEG		2	
23	525 57 14-03	CYLINDER		4	
24	576 37 88-01	VALVE		4	23
26	525 87 35-01	SCREW EHHFM		24	4, 6
27	575 76 20-01	SEAL		4	23
28	587 18 63-02	FOOTPLATE		1	
29	586 15 94-01	SLEEVE		16	6
30	583 83 41-01	PROTECTION		1	
31	574 25 89-01	SCREW EHHFM		2	
32	525 61 80-01	SCREW EHHM		2	
33	525 39 55-01	WASHER		4	
34	731 71 20-51	HEXAGON NUT FLANGE		2	

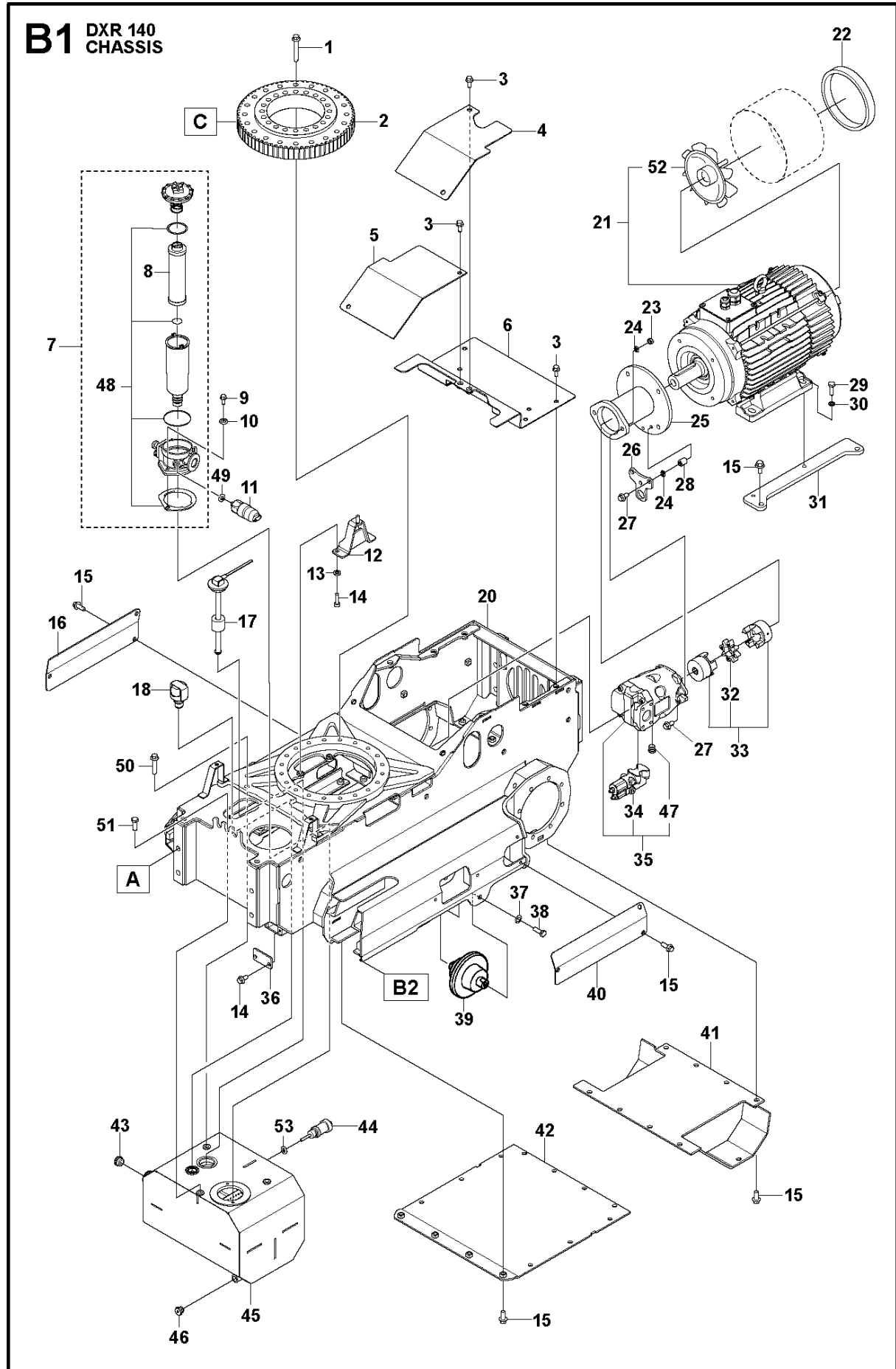

## CHASSIS

DXR140, Valid for machine 1 to 254, 2019-06

Ref	Part No	Description	Remark	QTY	KIT
1	575 28 66-01	SCREW EHHM		20	
2	525 75 61-01	BEARING		1	
3	574 25 89-01	SCREW EHHFM		6	
4	529 29 22-01	COVER		1	
5	574 62 31-01	COVER		1	
6	529 29 15-01	COVER		1	
7	576 38 86-01	KIT		1	
8	573 95 16-01	FILTER		1	7
9	725 54 53-01	SCREW IHSCM		2	
10	502 40 71-03	WASHER		2	
11	510 14 17-01	SWITCH		1	
12	529 27 80-01	BRACKET		1	
13	576 74 41-01	WASHER		2	
14	725 54 55-55	SCREW IHSCM		2	
15	522 70 66-01	SCREW EHHFM		14	
16	575 43 69-01	COVER		1	
17	573 95 18-01	LEVEL GLASS		1	
18	505 29 06-01	AIR FILTER		1	
20	583 96 43-01	MAIN BODY	Valid for machine S/N 1-254	1	
20	579 67 34-01	MAIN BODY	Valid for machine S/N 255-forward	1	
21	587 97 78-01	MOTOR	15 kW	1	
22	575 85 05-05	SEALING STRIP		1	
23	522 66 95-01	LOCK NUT		2	
24	522 67 17-01	WASHER		4	
25	574 71 34-01	BRACKET		1	
26	574 71 71-01	BRACKET		1	
27	574 25 11-01	SCREW EHHFM		9	
28	522 51 65-01	SLEEVE		2	
29	725 24 95-76	SCREW EHHM		4	
30	522 44 98-01	WASHER		4	
31	529 31 72-01	BRACKET		2	
32	525 75 50-01	COUPLING		1	33
33	525 75 41-01	COUPLING		1	
34	576 37 89-01	REGULATOR		1	35
35	525 75 53-01	HYDRAULIC PUMP		1	
36	575 84 94-01	COVER		1	
37	510 24 36-01	WASHER		4	
38	574 25 59-01	SCREW EHHM		4	
39	525 80 08-01	SUPPORT ROLLER	Valid for machine S/N 1-128	1	
39	505 26 86-01	SUPPORT ROLLER	Valid for machine S/N 129-forward	1	
40	575 42 63-01	COVER	Valid for machine S/N 1-128	1	
40	583 95 83-01	COVER	Valid for machine S/N 129-forward	1	
41	529 28 64-01	PLATE		1	
42	529 28 99-01	PLATE		1	
43	574 71 40-01	INDICATOR		1	
44	510 19 58-02	GAUGE		1	
45	525 51 19-01	HYDRAULIC TANK		1	
46	589 02 17-01	PLUG		1	
47	578 39 18-01	PLUG	60 Hz	1	35
48	590 13 69-01	SEAL KIT		1	7
49	502 40 71-01	WASHER		1	
50	575 65 09-01	SCREW EHHFM		2	
51	574 25 11-01	SCREW EHHFM		6	
52	590 22 06-01	FAN		1	21
53	501 72 09-03	WASHER		1	

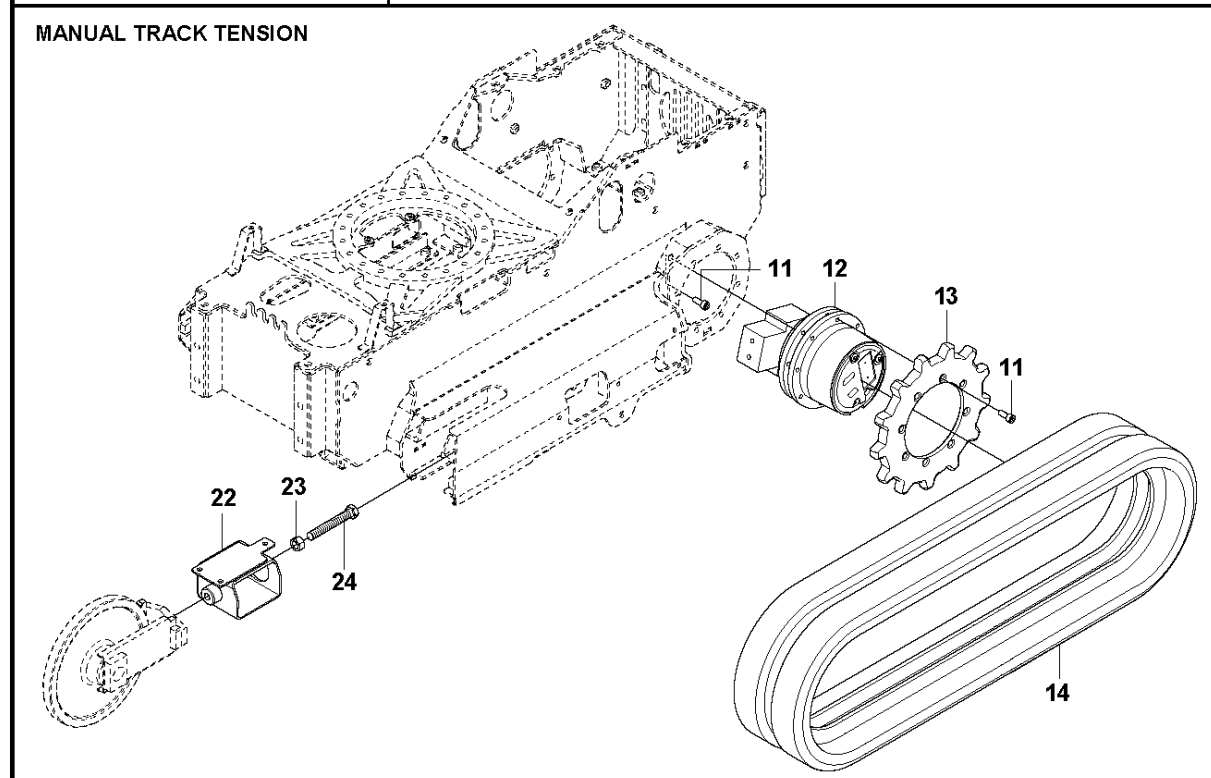
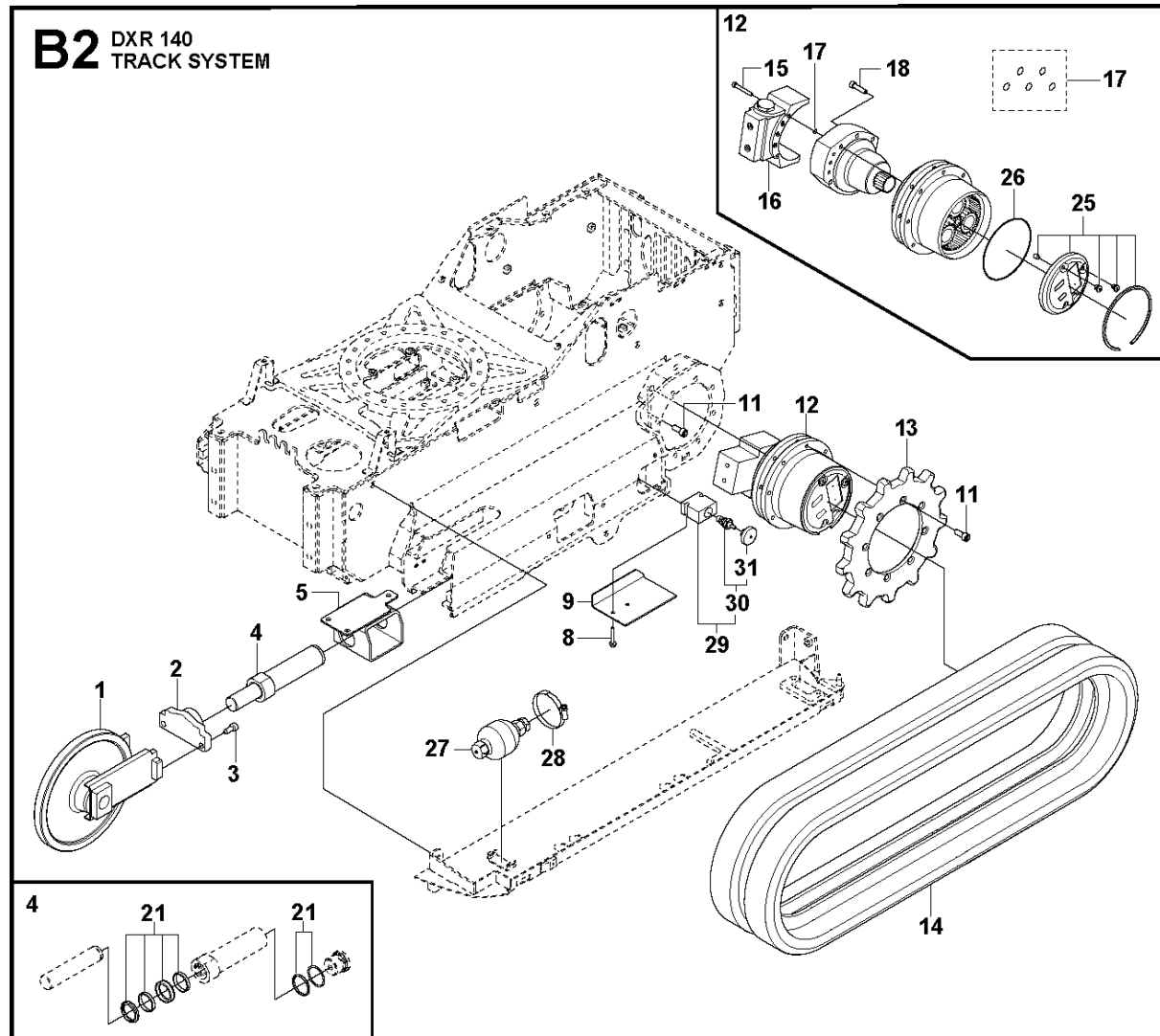

## TRACK SYSTEM

DXR140, Valid for machine 1 to 254, 2019-06

Ref	Part No	Description	Remark	QTY	KIT
1	525 80 09-01	TENSION ROLLER		2	
2	579 31 77-01	PLATE		2	
3	725 54 95-01	SCREW IHSCM		4	
4	505 26 74-01	CYLINDER		2	
5	575 38 91-01	TUBE	LH	1	
5	575 38 96-01	TUBE	RH	1	
8	522 70 70-01	SCREW EHHFM		2	
9	575 39 13-01	PROTECTION		1	
11	501 06 21-01	SCREW IHSCM		16	
12	574 70 11-01	DRIVE MOTOR		2	
13	525 79 75-01	SPROCKET		2	
14	579 32 84-01	RUBBER TRACKS		2	
15	725 54 67-51	SCREW IHSCM		4	12
16	522 96 49-01	VALVE KIT		2	12
17	522 96 50-01	SEAL		2	12
18	725 54 61-51	SCREW IHSCM		14	12
18	725 54 57-51	SCREW IHSCM		8	
21	522 85 76-01	SEAL		2	4
22	574 71 77-01	TUBE	LH	1	
22	574 71 79-01	TUBE	RH	1	
23	575 29 29-01	NUT		2	
24	575 29 31-01	SCREW EHHM		2	
25	590 14 32-01	COVER KIT		2	12
26	590 34 21-01	O-RING		2	12
27	575 59 56-01	ACCUMULATOR		1	
28	575 61 14-01	HOSE CLAMP		1	
29	575 59 66-01	CONTROL VALVE		1	
30	515 98 18-01	VALVE		1	29
31	576 38 54-01	KNOB		1	29, 30

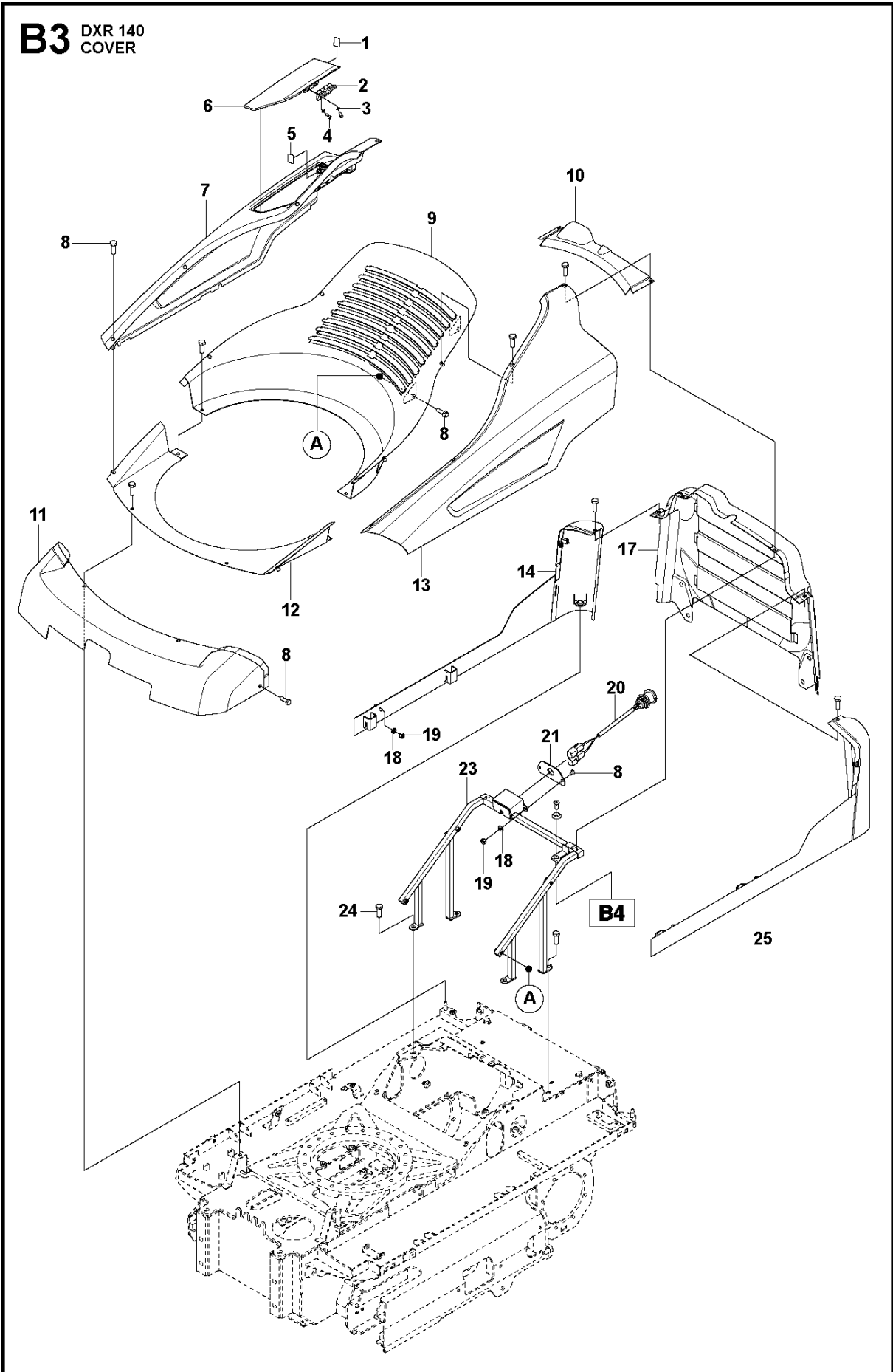



## COVER

DXR140, Valid for machine 1 to 254, 2019-06

Ref	Part No	Description	Remark	QTY KIT
1	575 78 31-01	LATCH		1
2	510 36 21-01	HINGE		1
3	576 41 78-01	WASHER		4
4	725 53 27-01	SCREW IHSCM		4
5	574 71 62-01	MAGNET		1
6	574 62 63-01	COVER		1
7	574 52 49-01	COVER		1
8	522 66 86-01	SCREW EHHFM		14
9	577 02 80-01	COVER		1
10	574 52 90-01	COVER		1
11	574 53 15-01	COVER		1
12	577 01 74-01	COVER		1
13	574 56 28-01	COVER		1
14	574 52 35-01	COVER		1
17	574 52 91-01	COVER		1
18	522 67 15-01	WASHER		8
19	522 66 93-02	LOCK NUT		10
20	584 85 16-01	SWITCH		1
21	574 68 37-01	LID		1
23	574 65 12-01	BRACKET		1
24	574 25 11-01	SCREW EHHFM		4
25	574 56 24-01	COVER		1

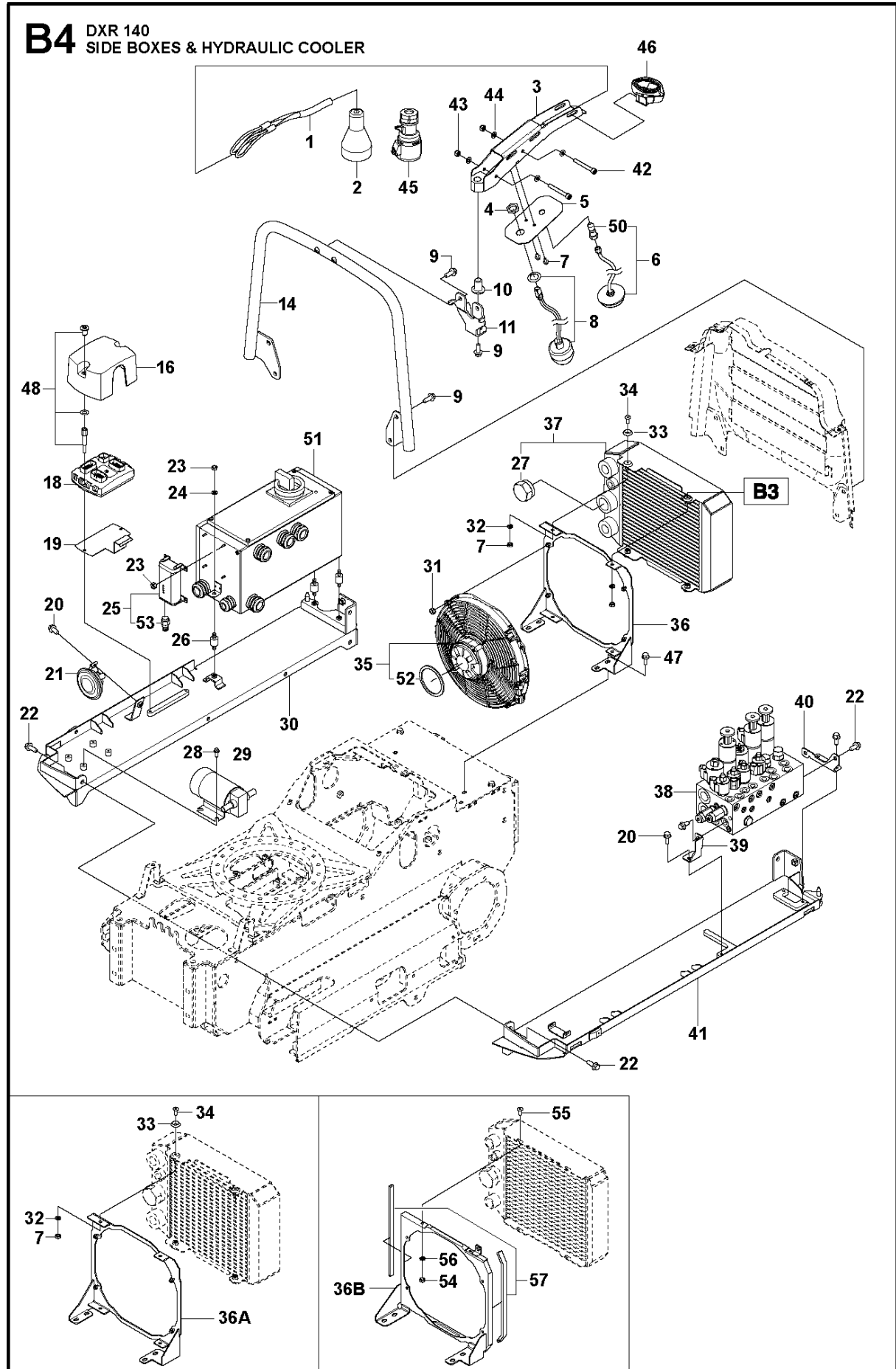

## SIDE BOXES &amp; HYDRAULIC COOLER

DXR140, Valid for machine 1 to 254, 2019-06

Ref	Part No	Description	Remark	QTY	KIT
1	574 66 78-01	CABLE CLAMP		1	
2	510 27 77-02	CABLE		1	
3	581 56 63-01	ARM		1	
4	581 48 08-01	NUT		1	
5	581 59 08-01	BRACKET		1	
6	580 28 92-01	ANTENNA		1	
7	522 66 94-01	LOCK NUT		2	
8	581 10 35-01	LIGHT		1	
9	574 25 89-01	SCREW EHHFM		3	
10	574 71 30-01	PIN		1	
11	581 59 15-01	BRACKET		1	
14	576 56 64-01	PROTECTOR BAR		1	
15	522 66 86-01	SCREW EHHFM		2	
16	574 66 49-01	PROTECTION		1	
17	574 70 15-01	SCREW		2	
18	576 73 75-01	ELECTRONIC BOX		1	
19	574 70 14-01	BRACKET		1	
20	725 24 47-51	SCREW		4	
21	510 12 60-01	HORN		1	
22	522 70 66-01	SCREW EHHFM		10	
23	732 25 12-01	HEXAGON LOCKING NUT		7	
24	522 67 15-01	WASHER		3	
25	505 27 45-01	ELECTRIC BOX		1	
26	575 72 77-01	DAMPER		3	
27a	585 31 48-01	VALVE	Valid for Hydac element, S/N 1-215	1	37a
27b	585 84 21-01	VALVE	Valid for Ymer element, S/N 216-forward	1	37b
28	522 66 84-01	SCREW EHHFM		4	
29	588 83 87-01	OIL PUMP	Valid for machine S/N 255-forward	1	
29	589 38 14-01	OIL PUMP	Valid for machine S/N 1-254	1	
30	573 97 24-01	BOX		1	
31	522 66 93-01	LOCK NUT		4	
32	522 67 16-01	WASHER		4	
33	523 04 24-01	WASHER		4	
34	725 64 51-01	SCREW IHCSFM		4	
35	523 03 20-01	FAN		1	
36a	574 71 07-01	BRACKET	For Hydac element, S/N 1-215	1	
36b	582 67 67-01	BRACKET	For Ymer element, S/N 216-forward	1	
37a	523 03 21-01	OIL COOLER	Hydac element, S/N 1-215	1	
37b	594 11 66-01	OIL COOLER	Ymer element, S/N 216-forward	1	
38	573 96 47-01	VALVE ASSY	Valid for machine S/N 1-254	1	
38	590 21 76-01	VALVE ASSY	Valid for machine S/N 255-forward	1	
39	574 69 25-01	BRACKET		1	
40	574 69 26-01	BRACKET		1	
41	573 97 23-01	BOX		1	
42	587 15 87-01	SCREW EHHM		2	
43	522 66 94-01	LOCK NUT		2	
44	522 67 16-01	WASHER		4	
45	531 11 71-31	SOCKET		1	
46	522 73 36-01	STRAP		1	
47	522 66 87-01	SCREW EHHFM		4	
48	574 70 15-01	SCREW		2	
50	592 64 65-01	ADAPTER		1	6
51	584 81 03-01	ELECTRONIC BOX		1	
52	582 18 02-01	SPACER RING		1	35
53	592 64 64-01	ADAPTER		1	25
54	522 66 93-01	LOCK NUT		16	
55	587 39 42-01	SCREW IHANM		7	
56	522 67 15-01	WASHER		19	
57	587 39 43-01	SEAL KIT		1	

**C1** DXR 140  
TOWER

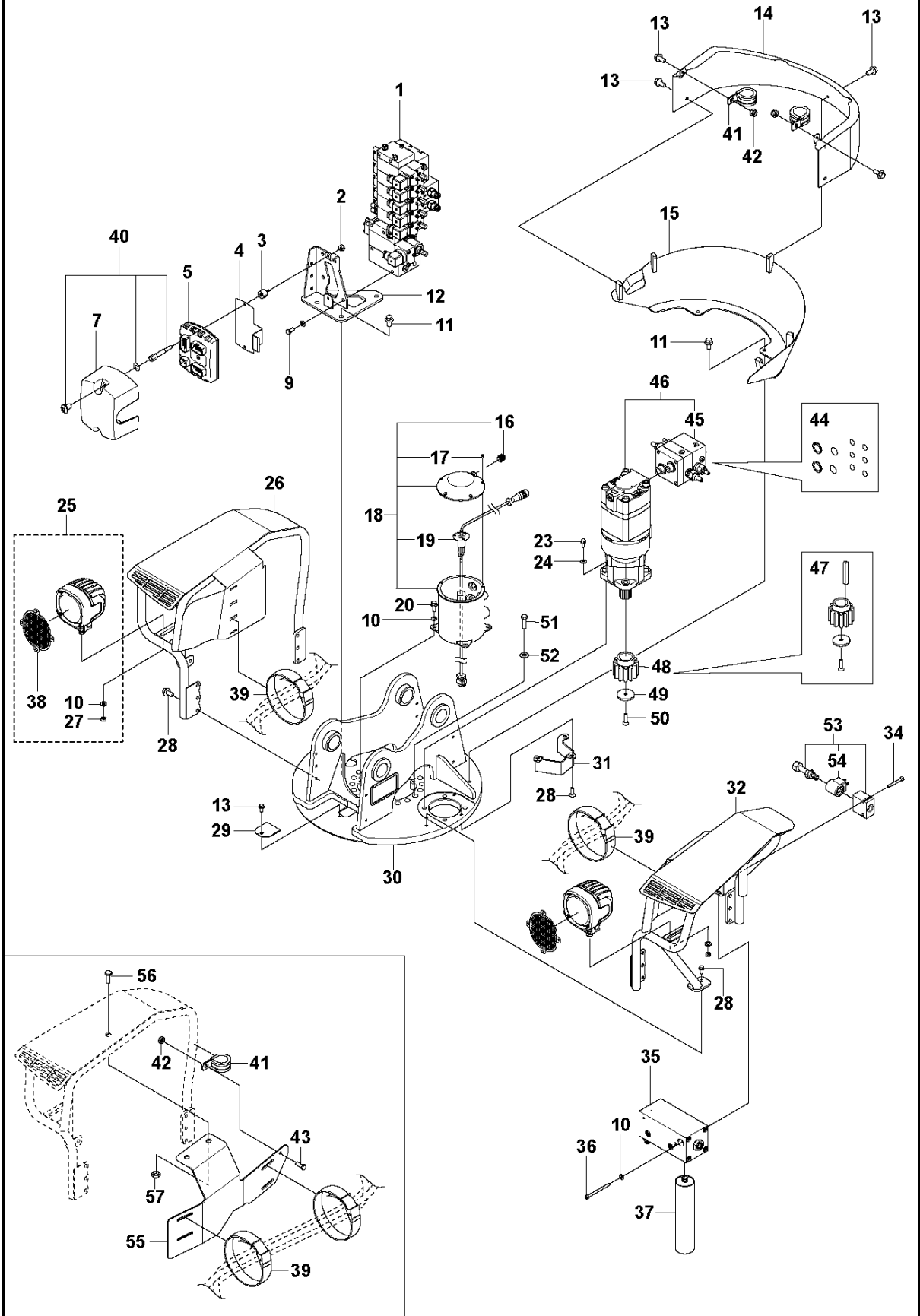

## TOWER

DXR140, Valid for machine 1 to 254, 2019-06

Ref	Part No	Description	Remark	QTY	KIT
1	585 45 09-01	BLOCK		1	
2	576 15 67-01	NUT		2	
3	575 72 78-01	DAMPER		2	
4	574 70 14-01	BRACKET		1	
5	576 73 75-02	ELECTRONIC BOX		1	
6	574 70 15-01	SCREW		2	
7	574 66 49-01	PROTECTION		1	
9	522 66 78-01	SCREW EHHM		2	
10	734 11 63-01	WASHER		10	25
11	522 70 66-01	SCREW EHHFM		5	
12	525 85 98-01	CONSOLE		1	
13	522 66 86-01	SCREW EHHFM		1	
14	588 08 16-01	COVER		1	
15	588 06 56-01	COVER		1	
16	576 67 61-01	CABLE		1	18
17	576 67 60-01	SCREW IHSCM		5	18
18	579 65 31-01	SWIVEL		1	
19	576 67 59-01	SWIVEL		1	18
20	725 54 53-01	SCREW IHSCM		4	
23	510 24 12-01	SCREW IHSCM		4	
24	510 24 36-01	WASHER		4	
25	588 12 61-01	LIGHT		2	
26	588 11 04-01	FRAME		1	
27	522 66 94-01	LOCK NUT		2	25
28	522 70 71-02	SCREW EHHFM		13	
29	576 43 49-01	COVER		1	
30	525 84 61-01	BASEPLATE		1	
31	575 81 45-01	PROTECTION		1	
32	588 15 98-01	FRAME		1	
34	503 20 00-33	SCREW EHHFM		2	
35	505 27 78-01	PUMP		1	
36	576 15 49-01	SCREW		2	
37	521 91 77-01	GREASE		1	
38	588 90 38-01	LENS	For old work light, 573 96 49-01	1	25
38	588 90 36-01	LENS	For new work light, 588 12 61-01	1	25
39	522 73 36-01	STRAP		4	
40	574 70 15-01	SCREW		2	
41	583 83 12-01	HOSE CLAMP		2	
42	522 66 93-01	LOCK NUT		1	
44	579 83 43-01	SEAL KIT		1	45, 46
45	576 37 93-01	VALVE		1	46
46	579 42 83-01	SLEWING DRIVE		1	
47	591 16 19-01	LOOSE PARTS KIT	For old slew motor with key shaft	1	
48	590 50 32-01	PINION	For new slew motor with spline shaft	1	
49	590 50 28-01	WASHER		1	
50	725 64 55-51	SCREW IHCSFM		1	
51	574 25 75-01	SCREW EHHM		21	
52	510 24 36-01	WASHER		31	
53	522 74 00-01	CONTROL VALVE		1	
54	522 96 30-01	SOLENOID		1	53
55	581 91 73-01	PROTECTIVE PLATE	Valid for machine S/N 1-106	1	
56	522 70 66-01	SCREW EHHFM		51	
57	522 66 95-01	LOCK NUT		18	

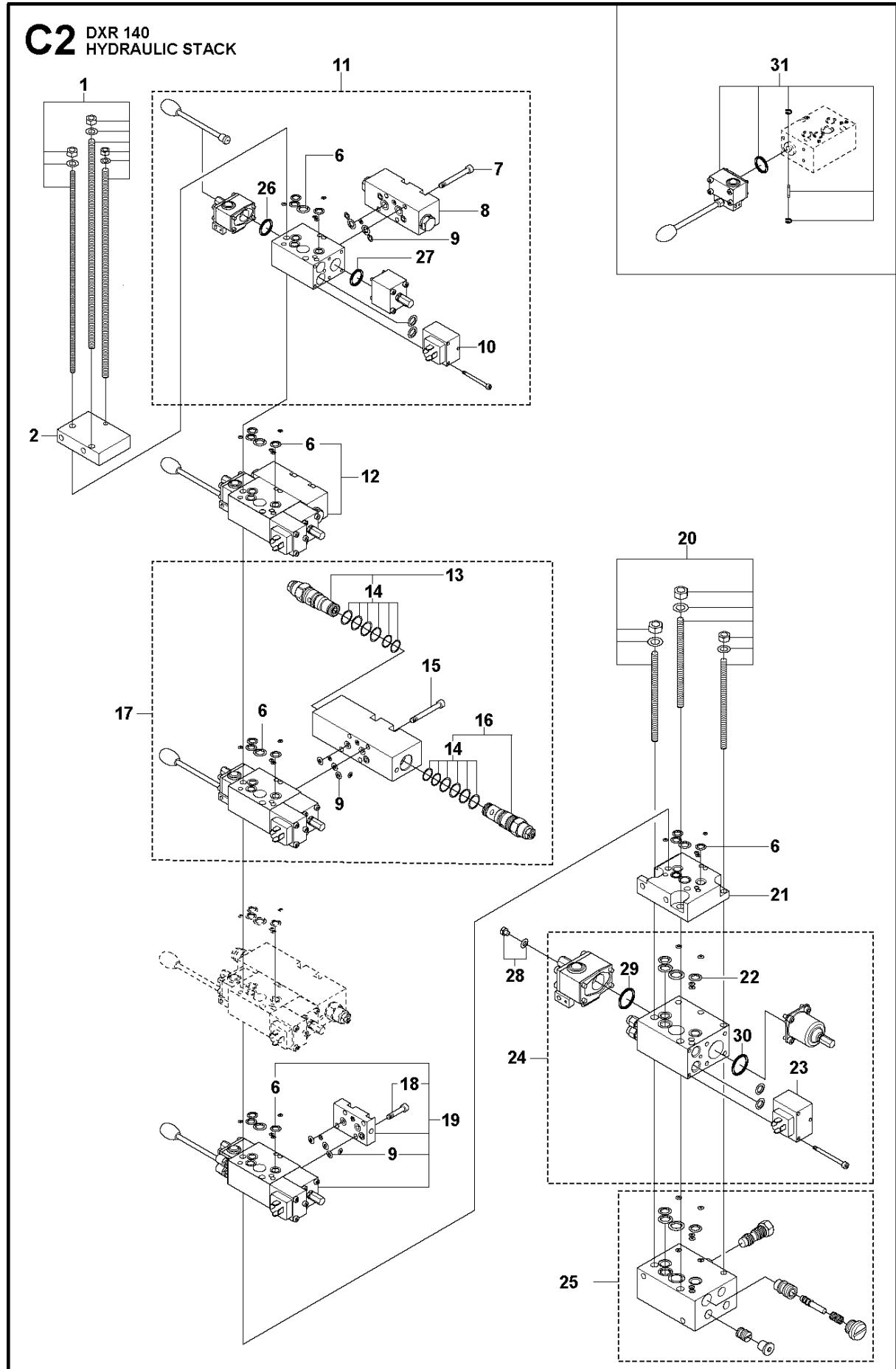

## HYDRAULIC STACK

DXR140, Valid for machine 1 to 254, 2019-06

Ref	Part No	Description	Remark	QTY	KIT
1	522 96 34-01	TAP	5 sections	1	
1	523 06 20-01	TAP	Extra hydraulic function 1 (6 sections)	1	
1	523 06 24-01	TAP	Extra hydraulic function 2 (7 sections)	1	
2	522 80 04-01	VALVE		1	
6	522 96 14-01	O-RING		1	11, 12, 17, 19
7	725 53 78-51	SCREW IHSCM		8	11
8	522 96 25-01	VALVE		2	11
9	522 96 16-01	O-RING		1	11, 17, 19
10	522 96 13-01	SOLENOID		1	11
11	576 30 36-01	VALVE	Cylinder 4	1	
12	576 30 15-01	VALVE	Cylinder 3	1	
13	522 96 23-01	VALVE		1	17
14	522 96 24-01	O-RING		2	13, 16, 17
15	725 53 80-51	SCREW IHSCM		8	17
16	522 96 22-01	VALVE		1	17
17	576 29 70-01	VALVE	Cylinder 1/2	2	
18	725 53 68-01	SCREW IHSCM		1	19
19	576 30 61-01	VALVE	Slew	1	
20	522 96 33-01	TAP		1	
21	522 79 98-01	VALVE		1	
22	522 96 19-01	O-RING		1	24
23	522 96 18-01	SOLENOID		1	24
24	576 31 14-01	VALVE		1	
25	576 31 23-01	VALVE		1	
26	TBD	TBD		10	11
27	TBD	TBD		10	11
28	501 11 56-01	LOOSE PARTS KIT	Stroke limiter removal kit	1	
29	TBD	TBD		1	24
30	TBD	TBD		1	24
31	585 82 37-01	HYDRAULIC KIT	Manual maneuver kit	5	

**C3** DXR 140 - S/N: 1-121  
HYDRAULIC BLOCK

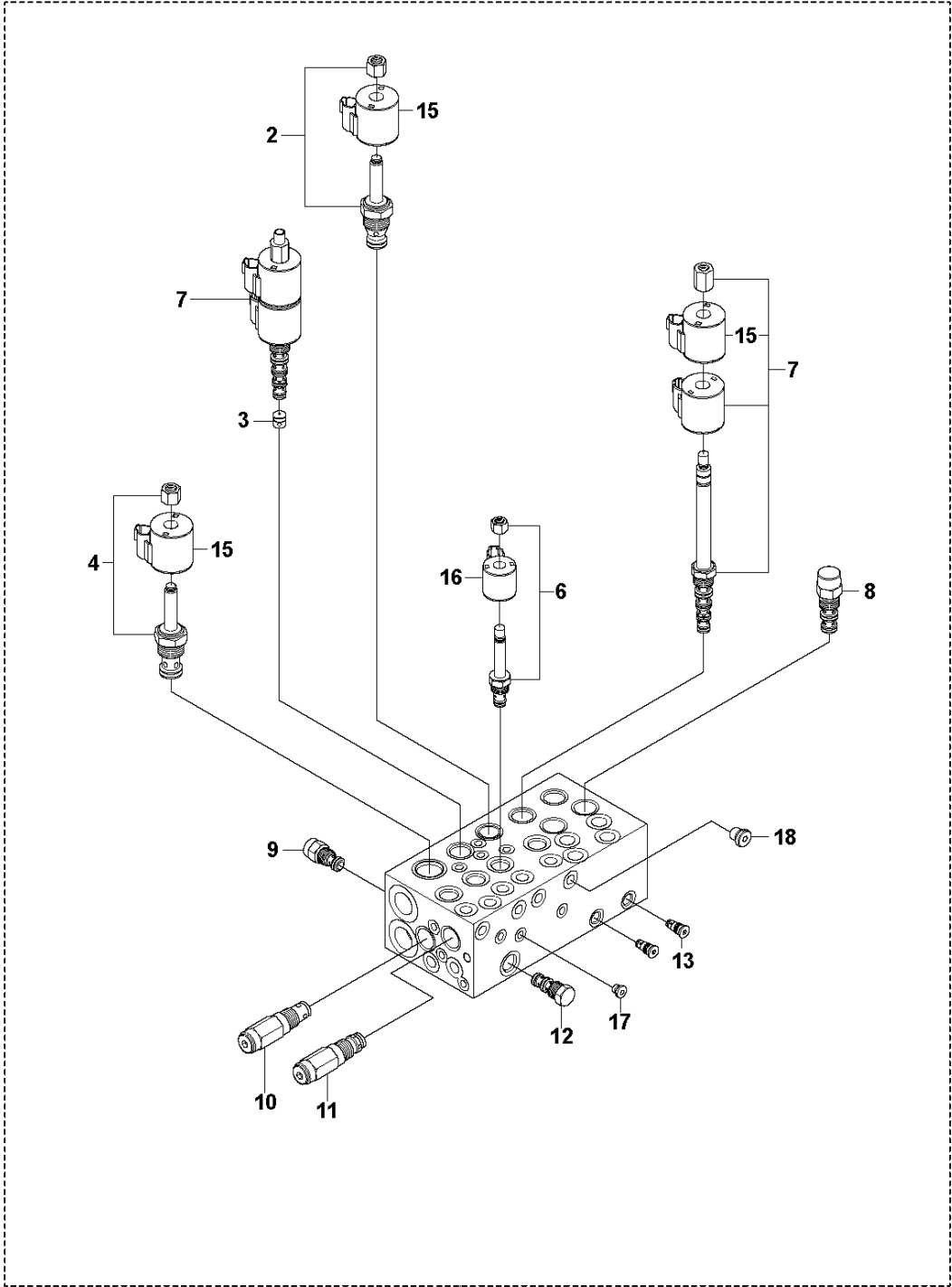

14



Ref	Part No	Description	Remark	QTY KIT	
2	576 34 75-01	VALVE	Pressure Control	1	14
3	576 34 67-01	VALVE	Outriggers, load-sensing signal check valve	1	14
4	576 33 88-01	VALVE	Circulation, on/off valve	1	14
6	576 34 69-01	VALVE	Outriggers, on/off valve	4	14
7	576 33 89-01	VALVE	Outriggers / Tracks, prop. valve	3	14
8	576 34 68-01	VALVE	Tracks, pressure compensator valve	2	14
9	576 34 76-01	VALVE	Load-sensing signal, bleed valve	1	14
10	576 34 72-01	VALVE	System pressure relief valve, 280 bar	1	14
11	576 34 71-01	VALVE	Outriggers pressure relief valve, 20 bar	1	14
12	576 34 74-01	VALVE	Load-sensing signal, shuttle check valve	1	14
13	576 34 73-01	VALVE	Tracks, load-sensing signal check valve	2	14
14	573 96 47-01	VALVE ASSY		1	
15	576 33 90-01	SOLENOID		8	7, 14
16	576 34 70-01	SOLENOID		4	14
17	582 09 33-01	PLUG			14
18	582 09 32-01	PLUG			14

**C3** DXR 140 - S/N: 122-254  
HYDRAULIC BLOCK

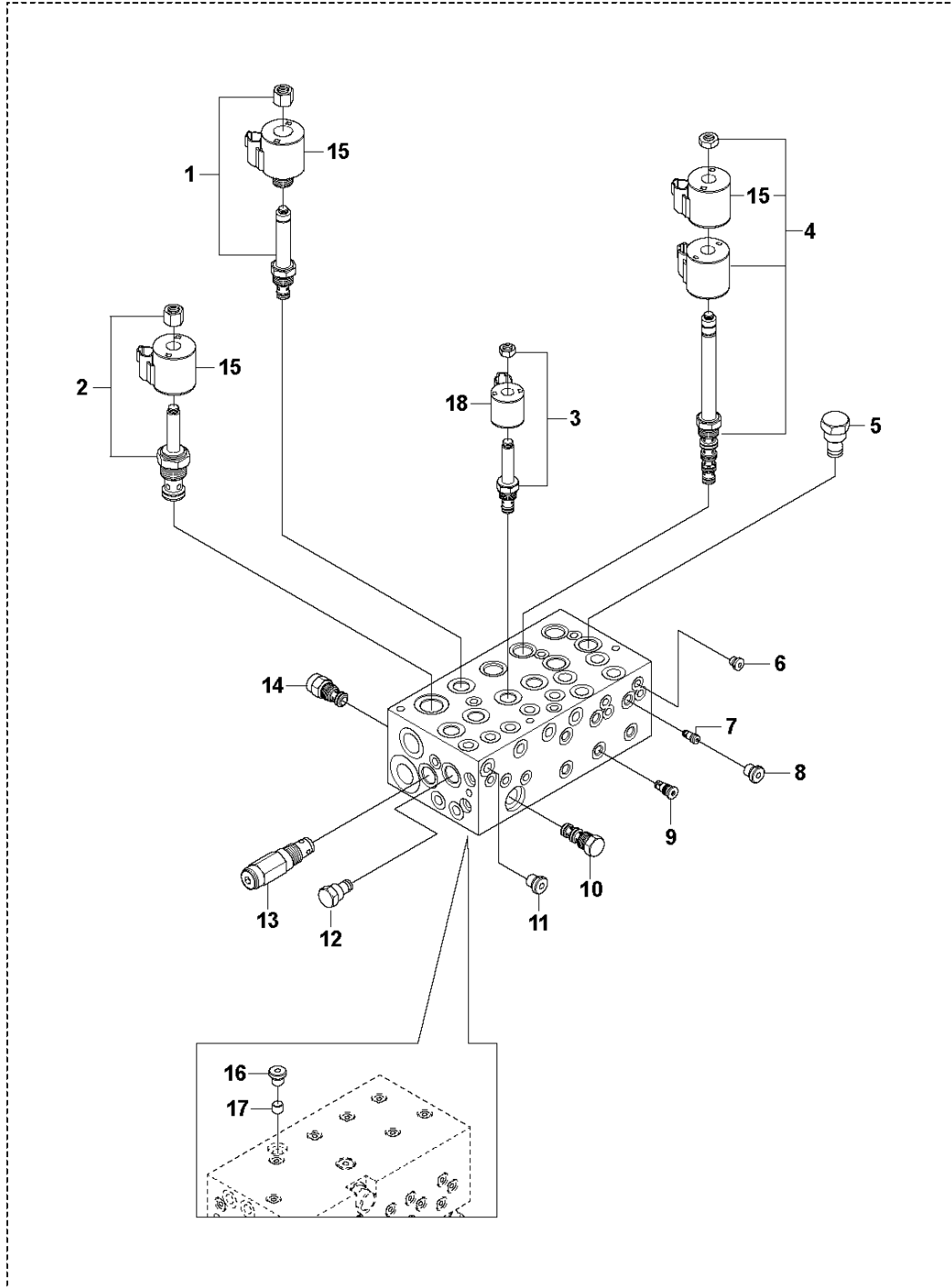

19

Ref	Part No	Description	Remark	QTY	KIT
1	576 34 75-01	VALVE	Pressure Control	1	19
2	576 33 88-01	VALVE	Circulation, on/off valve	1	19
3	586 29 53-01	VALVE	Outriggers, on/off valve	4	19
4	586 29 54-01	VALVE	Outriggers / Tracks, prop. valve	3	19
5	586 39 54-01	PLUG	Cavity Plug, 3-way	2	19
6	582 09 33-01	PLUG		34	19
7	586 29 55-01	VALVE	Outriggers / Tracks, load-sensing signal shuttel valve	3	19
8	582 09 31-01	PLUG		3	19
9	576 34 73-01	VALVE	Outriggers / Tracks, load-sensing signal check valve	3	19
10	576 34 74-01	VALVE	Load-sensing signal, shuttle check valve	1	19
11	582 09 32-01	PLUG		8	19
12	586 39 53-01	PLUG	Cavity Plug, 2-way	1	19
13	576 34 72-01	VALVE	System pressure relief valve, 280 bar	1	19
14	576 34 76-01	VALVE	Load-sensing signal, bleed valve	1	19
15	576 33 90-01	SOLENOID		8	4, 19
16	582 09 32-01	PLUG		8	19
17	TBD	TBD		1	19
18	576 34 70-01	SOLENOID		4	19
19	586 11 94-01	VALVE ASSY		1	

**D1** DXR 140  
ARM ONE

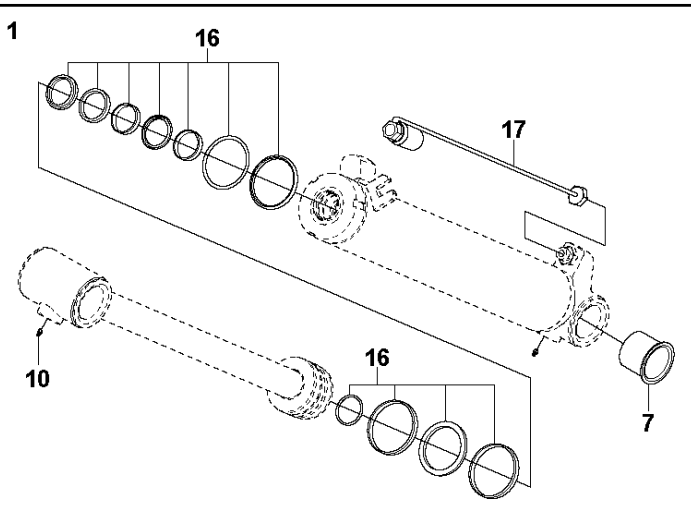
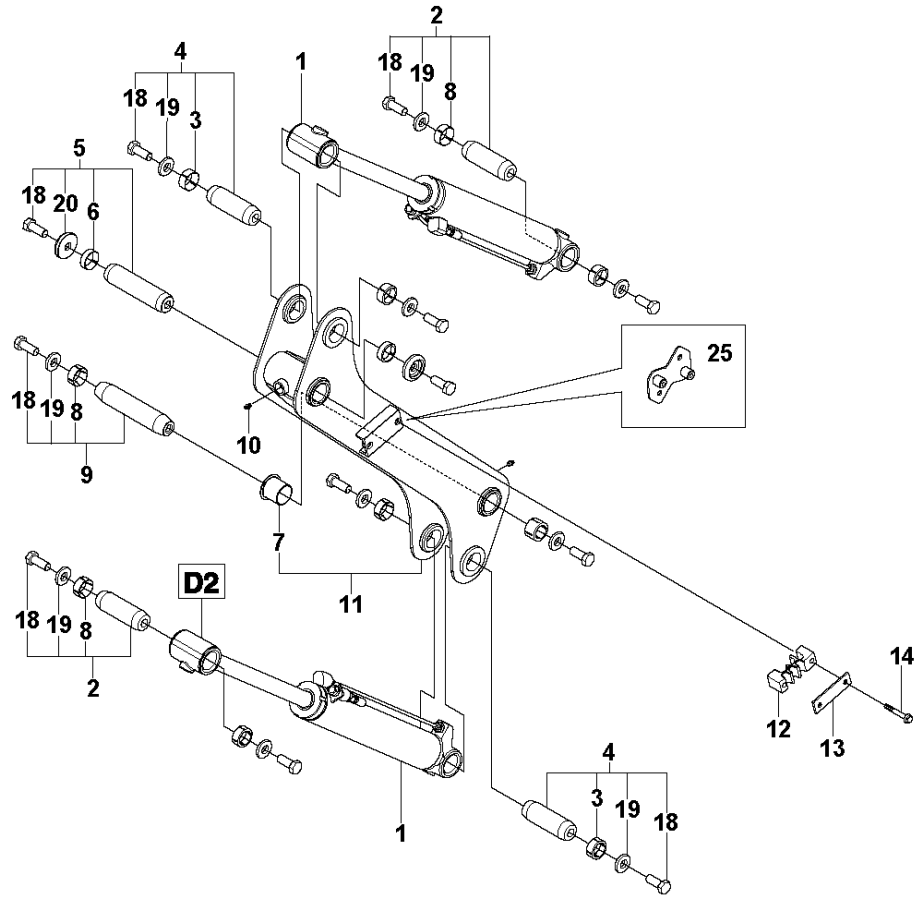
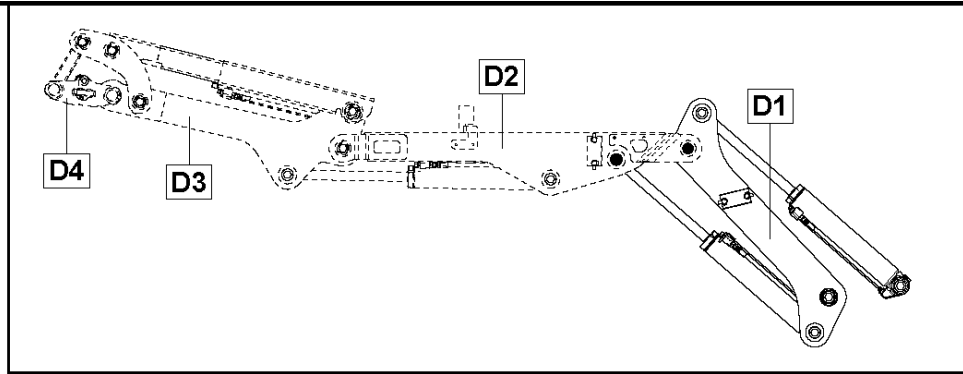

## ARM ONE

DXR140, Valid for machine 1 to 254, 2019-06

Ref	Part No	Description	Remark	QTY	KIT
1	525 57 13-01	CYLINDER		2	
2	525 76 32-01	SHAFT		2	
3	522 84 12-01	SLEEVE		6	4
4	525 76 22-01	SHAFT		3	
5	525 76 06-01	SHAFT		1	
6	522 84 11-01	SLEEVE		2	5
7	505 25 08-01	BEARING BUSH		12	1, 11
8	522 84 15-01	SLEEVE		4	2, 9
9	525 76 39-01	SHAFT		1	
10	504 89 53-01	LUBRICATION NIPPLE		6	1
11	525 43 03-01	ARM		1	
12	588 89 95-01	HOSE CLAMP		2	
13	588 90 10-01	PLATE		2	
14	725 25 03-55	SCREW EHHM		4	
16	576 45 42-01	SEAL		2	1
17	576 45 43-01	HYDRAULIC PIPE		2	1
18	522 84 23-01	SCREW EHHM		28	2, 4, 5, 9
19	582 30 03-01	WASHER		16	2, 4, 9
20	522 84 19-01	WASHER		10	5
25	581 89 99-01	BRACKET	Valid for machine S/N 1-106	1	

**D2** DXR 140  
ARM TWO

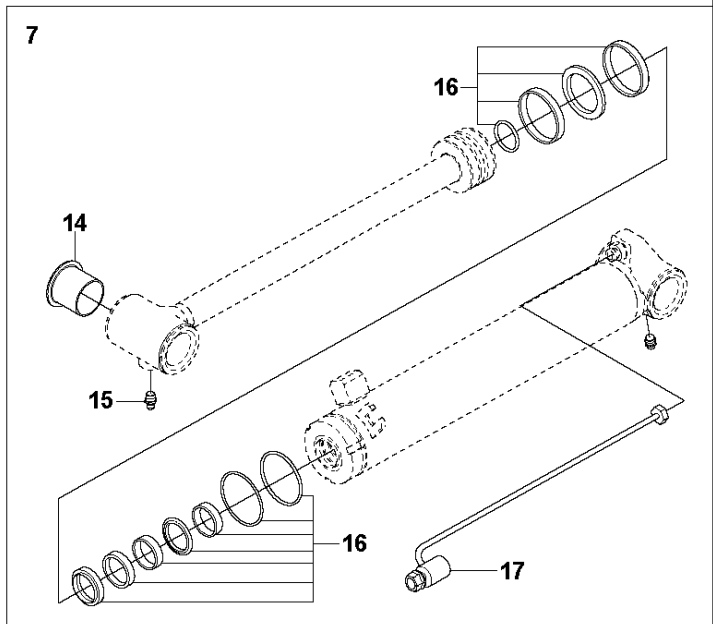
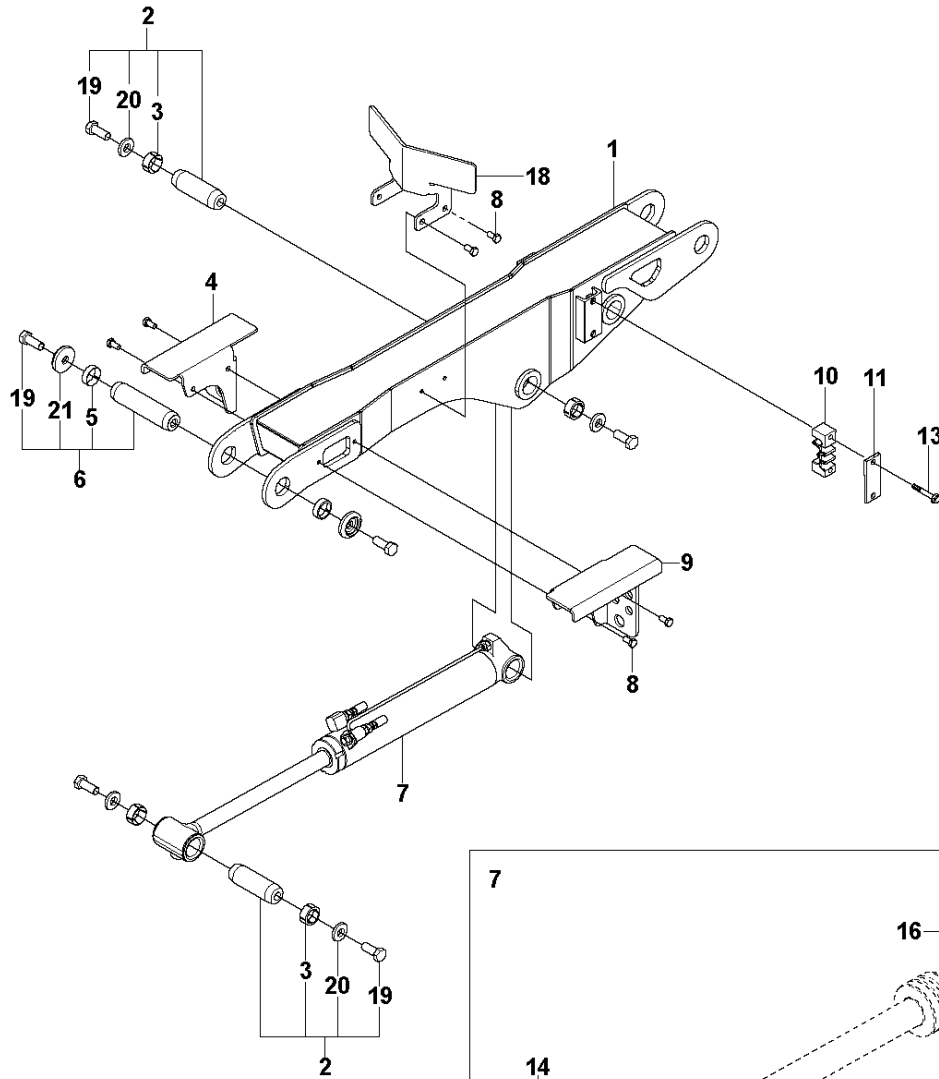
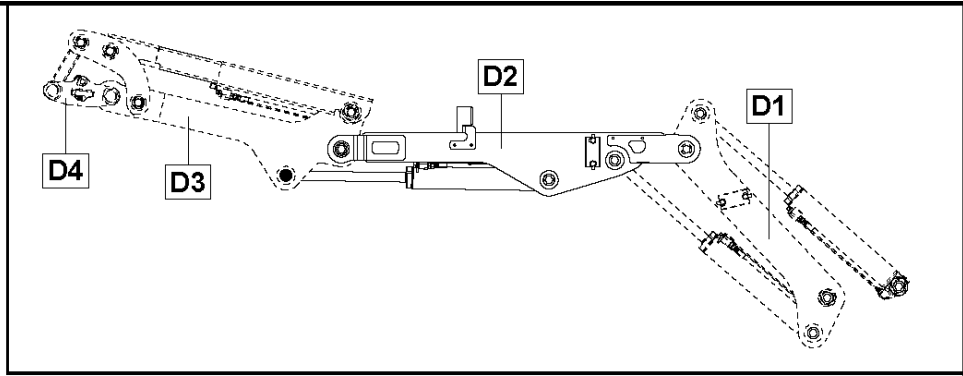

Ref	Part No	Description	Remark	QTY	KIT
1	581 83 64-01	ARM		1	
2	525 76 22-01	SHAFT		2	
3	522 84 12-01	SLEEVE		4	2
4	580 28 39-01	COVER		1	
5	522 84 11-01	SLEEVE		2	6
6	525 76 06-01	SHAFT		1	
7	525 57 13-01	CYLINDER		1	
8	574 25 89-01	SCREW EHHFM		4	
9	580 28 38-01	COVER		1	
10	588 89 95-01	HOSE CLAMP		2	
11	588 90 10-01	PLATE		2	
13	725 25 03-55	SCREW EHHM		4	
14	505 25 08-01	BEARING BUSH		4	7
15	504 89 53-01	LUBRICATION NIPPLE		2	7
16	576 45 42-01	SEAL		1	7
17	576 45 43-01	HYDRAULIC PIPE		1	7
18	581 87 88-01	PLATE		1	
19	522 84 23-01	SCREW EHHM		30	2, 6
20	582 30 03-01	WASHER		16	2
21	522 84 19-01	WASHER		10	6

**D3** DXR 140  
ARM THREE

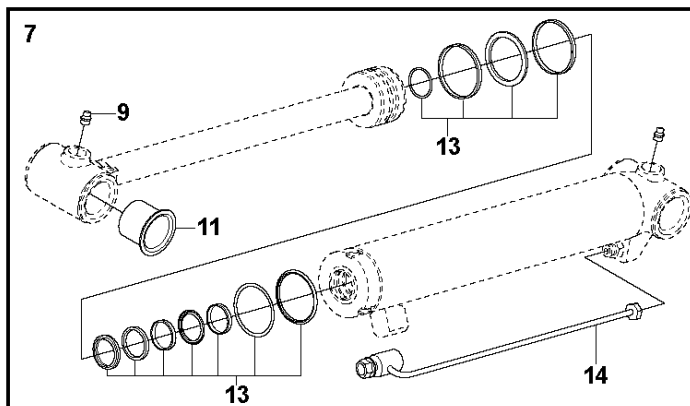
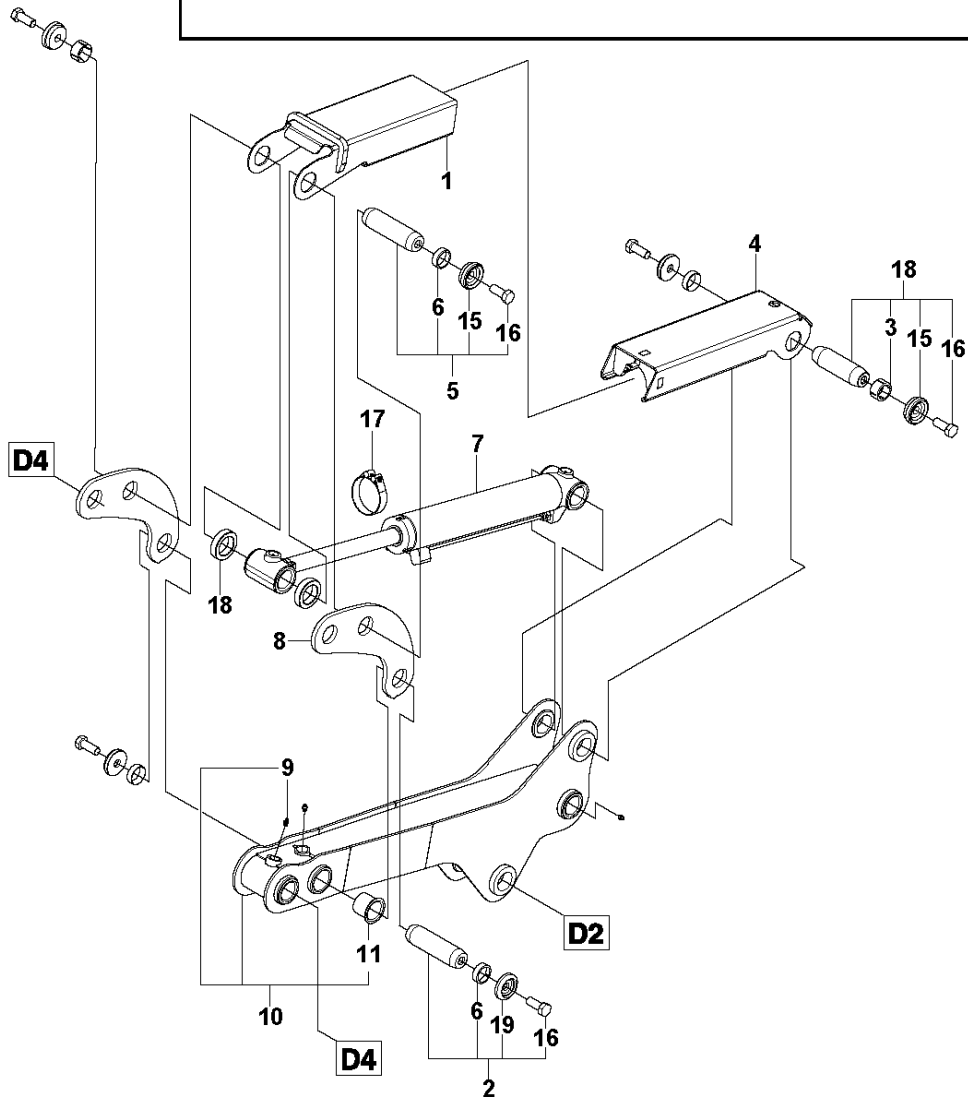
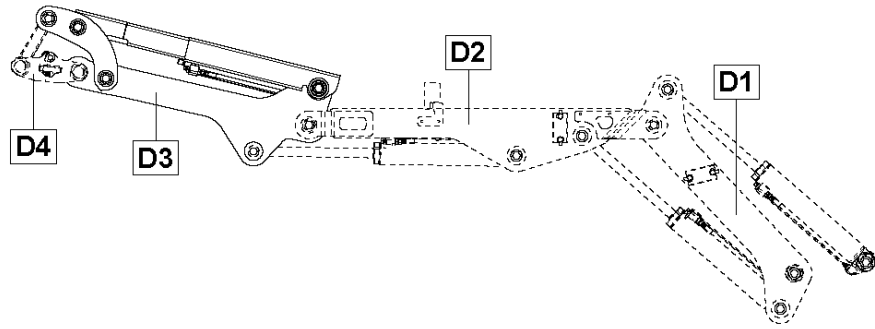



## ARM THREE

DXR140, Valid for machine 1 to 254, 2019-06

Ref	Part No	Description	Remark	QTY	KIT
1	592 76 64-01	PROTECTION		1	
2	525 76 27-01	SHAFT		2	
3	522 84 13-01	SLEEVE		2	18
4	592 76 66-01	PROTECTION		1	
5	582 65 37-01	SHAFT ASSY		1	
6	522 84 11-01	SLEEVE		8	2, 5
7	525 57 13-01	CYLINDER		1	
8	525 47 66-01	PLATE		2	
9	504 89 53-01	LUBRICATION NIPPLE		5	7, 10
10	525 45 74-01	ARM		1	
11	505 25 08-01	BEARING BUSH		8	7, 10
13	576 45 42-01	SEAL		1	7
14	576 45 43-01	HYDRAULIC PIPE		1	7
15	582 29 99-01	WASHER		4	5, 18
16	522 84 11-01	SLEEVE		30	2, 5, 18
17	582 65 36-01	HOSE CLAMP		2	
18	591 18 61-01	SLEEVE		2	
19	522 84 19-01	WASHER		10	2

**D4** DXR 140  
TOOL HOLDER

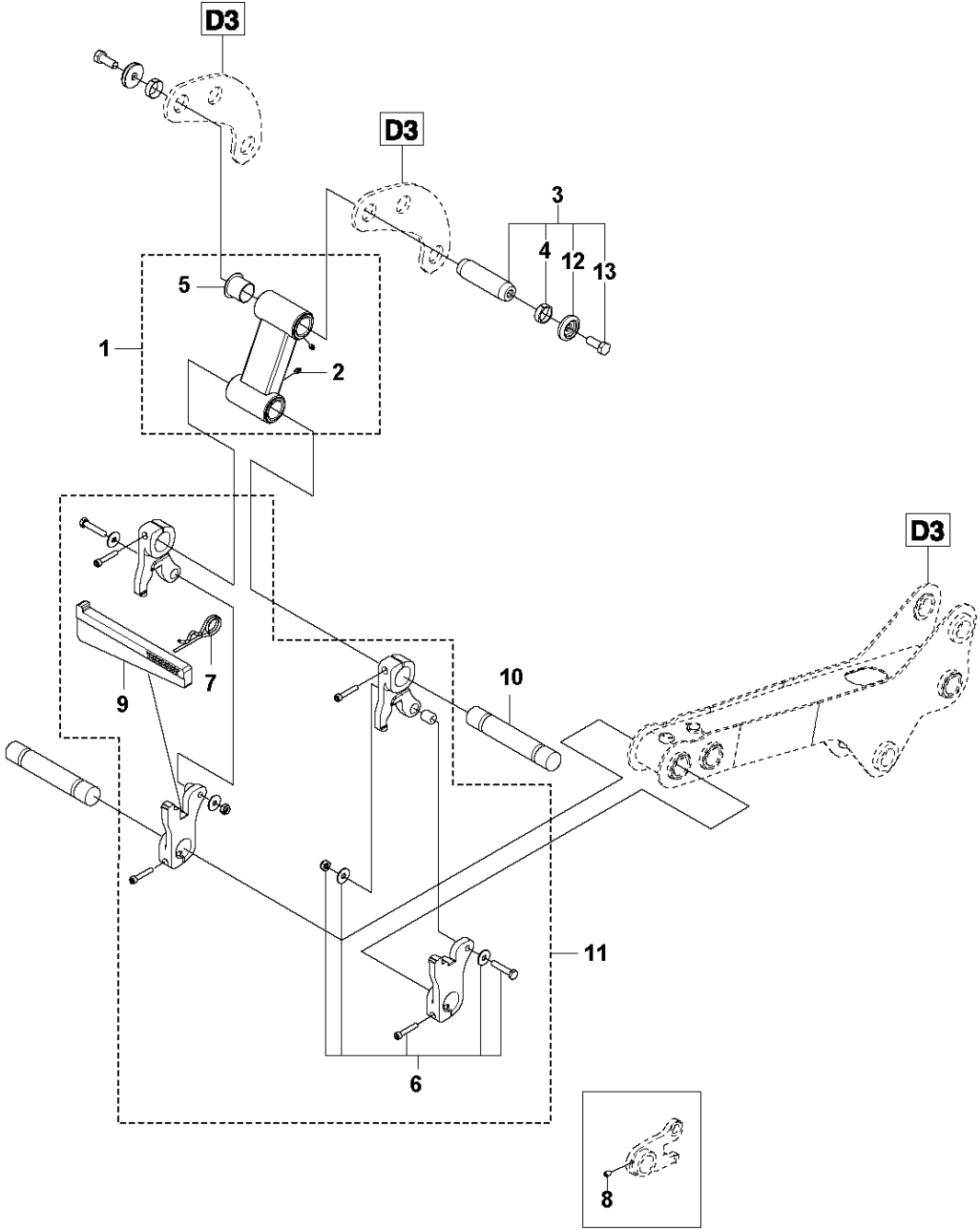
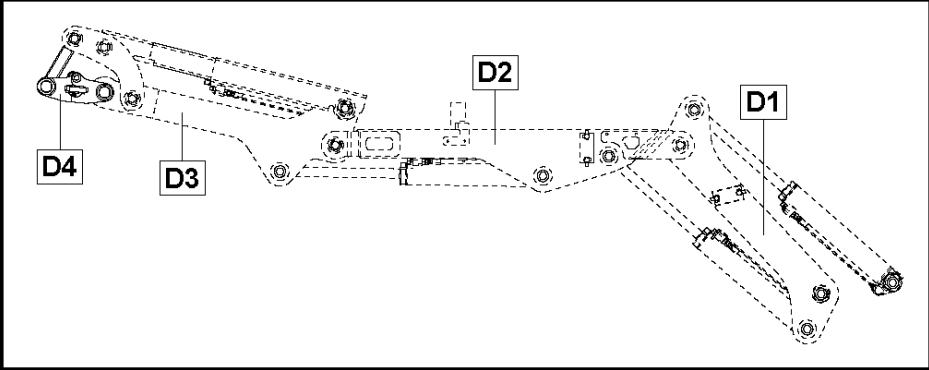

## TOOL HOLDER

DXR140, Valid for machine 1 to 254, 2019-06

Ref	Part No	Description	Remark	QTY	KIT
1	525 47 67-01	ARM		1	
2	504 89 53-01	LUBRICATION NIPPLE		2	1
3	525 76 27-01	SHAFT		1	
4	522 84 11-01	SLEEVE		2	3
5	505 25 08-01	BEARING BUSH		6	1
6	582 60 61-01	LOOSE PARTS KIT		1	11
6	576 45 62-01	KIT	valid for old tool hitch	1	11
7	588 93 82-01	COTTER		1	11
7	505 32 30-01	CLIP	valid for old tool hitch	1	11
8	522 70 65-01	SCREW IHSETM	valid for old tool hitch	4	11
9	586 37 71-01	WEDGE		1	11
9	505 32 26-01	WEDGE	valid for old tool hitch	1	11
10	579 67 82-01	SHAFT		1	
10	525 84 51-01	SHAFT	valid for old tool hitch	2	
11	588 97 89-01	HITCH		1	
11	575 88 44-01	HITCH	valid for old tool hitch	1	
12	582 29 99-01	WASHER		4	3
13	523 84 23-01	ZUSATZGRIFF KLEIN		30	3

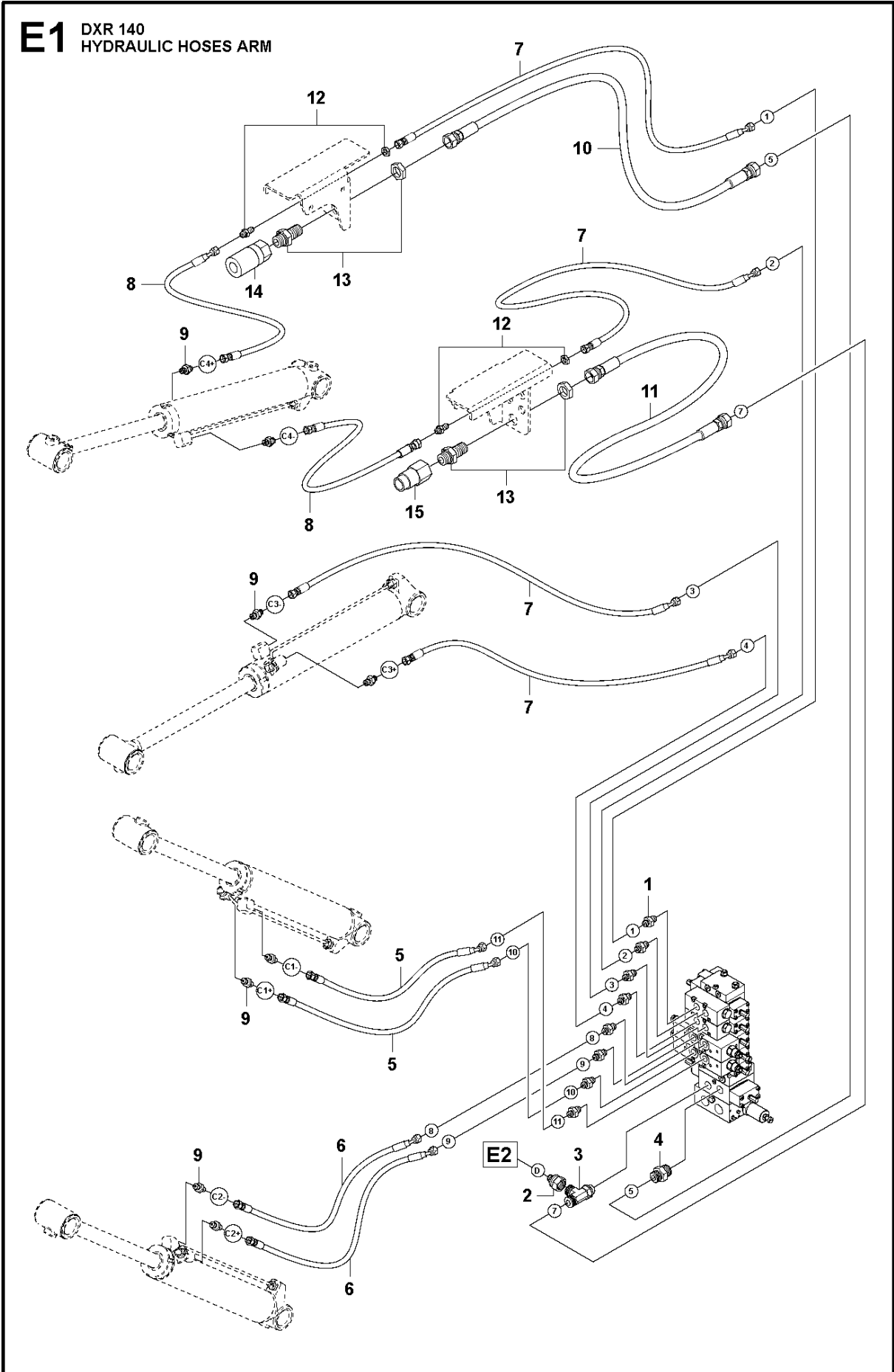

## HYDRAULIC HOSES ARM

DXR140, Valid for machine 1 to 254, 2019-06

Ref	Part No	Description	Remark	QTY KIT
1	522 73 00-01	ADAPTER		10
2	522 83 74-01	ADAPTER		1
3	522 61 36-01	ADAPTER		1
4	574 24 61-01	ADAPTER		3
5	585 48 56-02	HOSE ASSY		3
6	510 23 48-07	HOSE ASSY		2
7	585 48 56-04	HOSE ASSY		4
8	585 48 42-01	HOSE ASSY		10
9	510 24 57-01	ADAPTER		37
10	574 24 57-04	HOSE ASSY		1
11	585 48 32-02	HOSE ASSY		2
12	589 00 88-01	ADAPTER		2
13	574 68 73-01	ADAPTER		2
14	510 26 81-01	QUICK COUPLING		1
15	510 26 80-01	QUICK COUPLING		1

**E2** DXR 140  
HYDRAULIC HOSES BASE PLATE

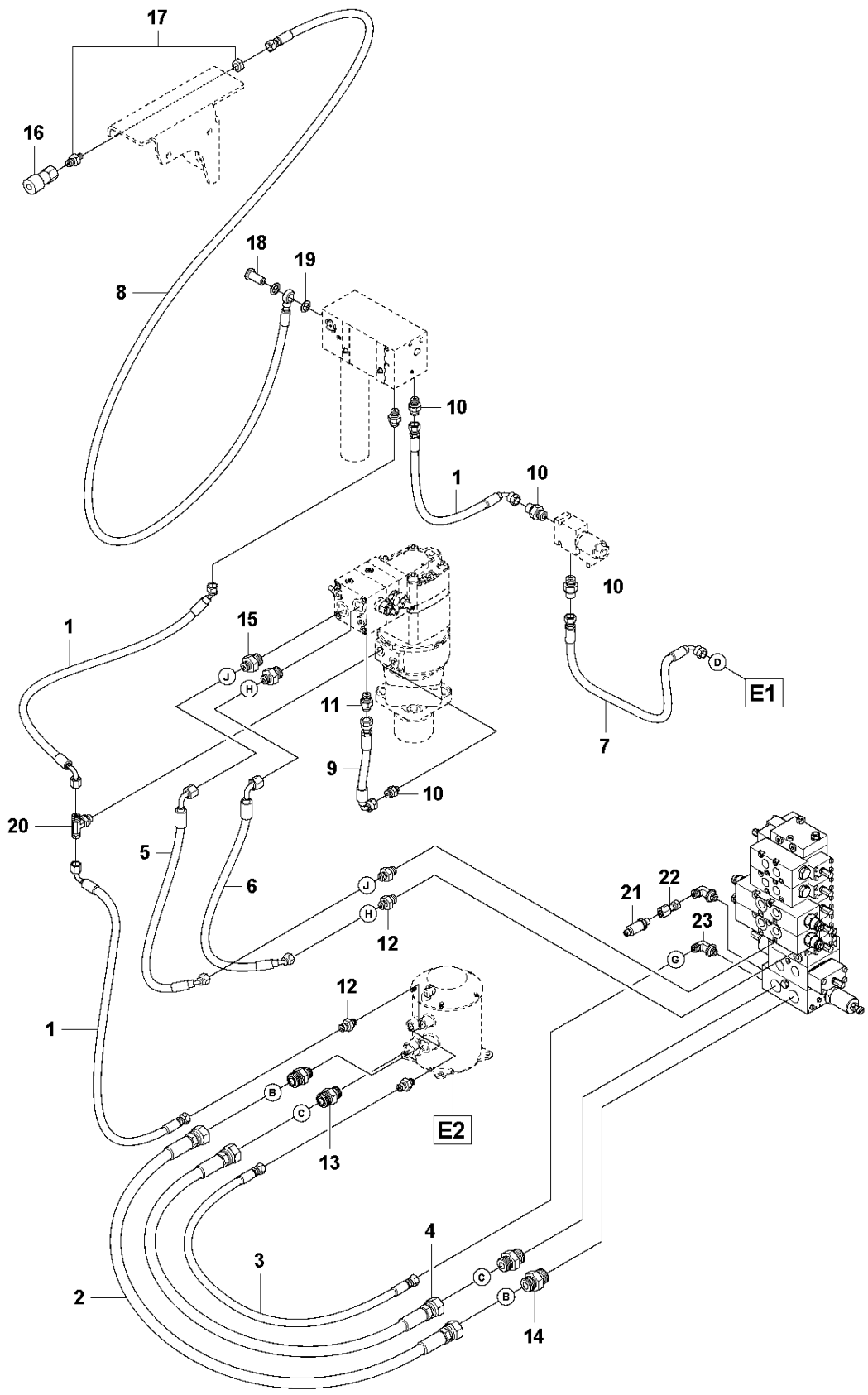

## HYDRAULIC HOSES BASE PLATE

DXR140, Valid for machine 1 to 254, 2019-06

Ref	Part No	Description	Remark	QTY KIT
1	510 25 18-12	HOSE ASSY		4
2	585 48 33-02	HOSE ASSY		2
3	510 25 18-13	HOSE ASSY		1
4	585 48 33-02	HOSE ASSY		2
5	582 31 37-01	HOSE ASSY		2
6	582 31 37-01	HOSE ASSY		2
7	522 67 25-17	HOSE ASSY		1
8	576 54 40-01	HOSE ASSY		1
9	585 48 55-05	HOSE ASSY		1
10	501 53 00-01	ADAPTER	Valid for machine S/N 1-254	7
10	589 01 08-01	ADAPTER	Valid for machine S/N 255-forward	1
11	589 01 09-01	ADAPTER		37
12	589 01 09-01	ADAPTER	"Valid for old machines with 1/4"" hose "	37
12	589 01 10-01	ADAPTER	"Valid for new machines with 3/8"" hose "	13
13	574 24 60-01	ADAPTER		3
14	574 24 61-01	ADAPTER		3
15	510 25 90-01	ADAPTER		2
16	510 26 79-01	QUICK COUPLING		1
17	510 25 79-01	ADAPTER		1
18	589 02 19-01	SCREW		1
19	501 72 09-01	WASHER		2
20	589 01 81-01	ADAPTER		1
21	522 49 53-02	SENSOR		1
22	510 40 87-01	ADAPTER		1
23	510 26 54-01	ADAPTER		2

**E3** DXR 140  
HYDRAULIC HOSES POWER PACK

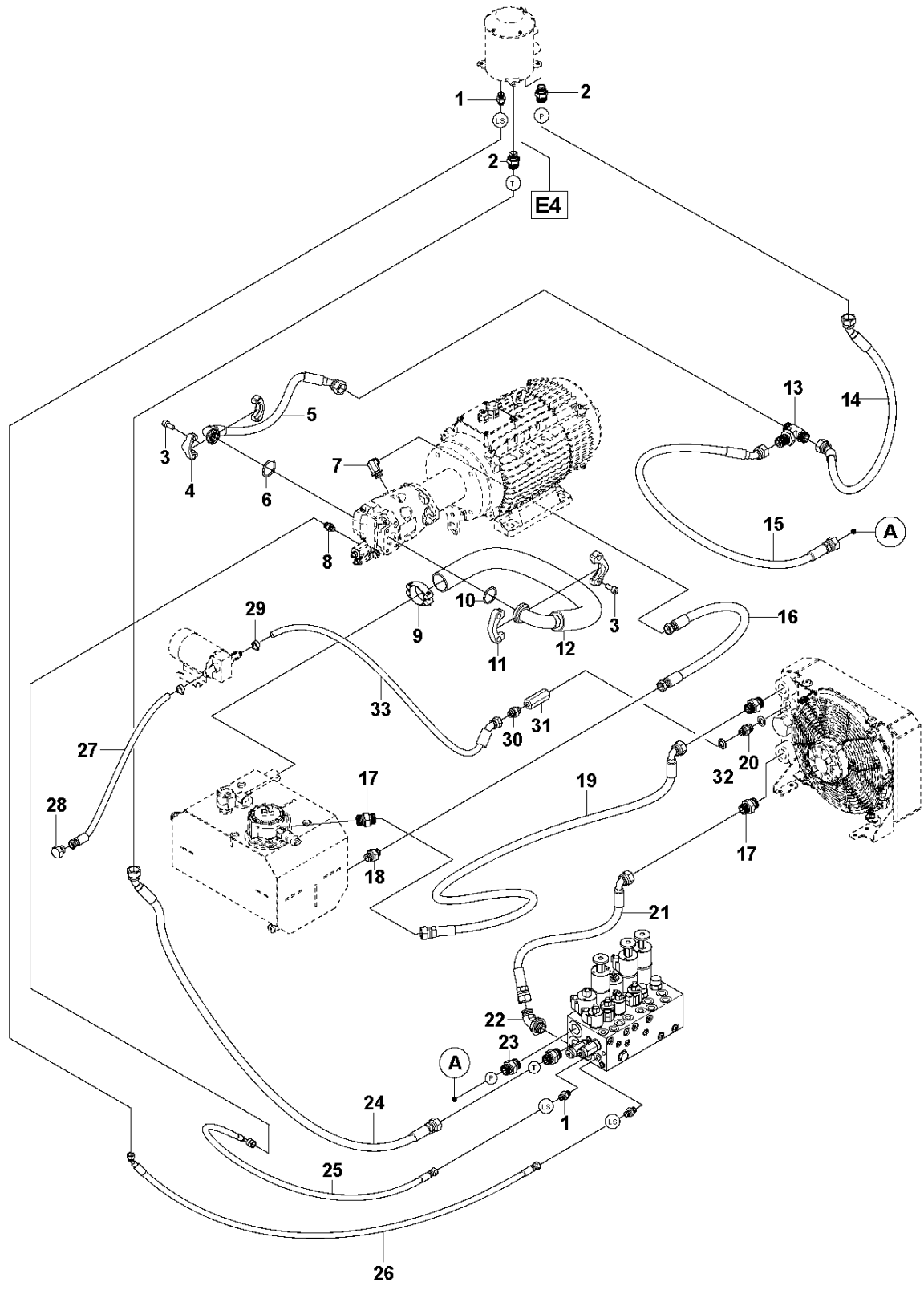



Ref	Part No	Description	Remark	QTY KIT
1	510 24 57-01	ADAPTER		19
2	574 24 60-01	ADAPTER		2
3	725 24 95-76	SCREW EHHM		8
4	574 24 12-01	FLANGE		2
5	576 03 42-01	HOSE ASSY		1
6	510 36 31-04	O-RING		1
7	574 89 08-01	ADAPTER		1
8	510 26 47-01	ADAPTER		1
9	510 36 32-02	HOSE CLAMP		1
10	510 36 31-03	O-RING		1
11	574 24 11-01	FLANGE		2
12	574 24 55-03	HOSE ASSY		1
13	574 68 74-01	ADAPTER		1
14	574 24 30-01	HOSE ASSY		1
15	574 24 32-04	HOSE ASSY		1
16	576 03 54-01	HOSE ASSY		1
17	510 26 46-01	ADAPTER		4
18	510 25 85-01	ADAPTER		1
19	510 19 53-03	HOSE ASSY		1
20	510 26 11-01	ADAPTER		1
21	576 03 53-01	HOSE ASSY		1
22	576 12 56-01	ADAPTER		1
23	574 24 61-01	ADAPTER		1
24	576 03 52-01	HOSE ASSY		1
25	522 67 25-11	HOSE ASSY		1
26	510 23 48-16	HOSE ASSY		1
27	585 48 57-01	HOSE ASSY		1
28	589 01 04-01	PLUG		1
29	522 67 20-01	HOSE CLAMP		2
30	589 01 96-01	ADAPTER		1
31	510 26 76-01	CHECK VALVE		1
32	501 72 09-02	WASHER	Valid for Ymer element, S/N 216-forward	2
33	501 46 48-02	HOSE ASSY		1

**E4** DXR 140  
HYDRAULIC HOSES TRACKS & SUPPORT LEGS

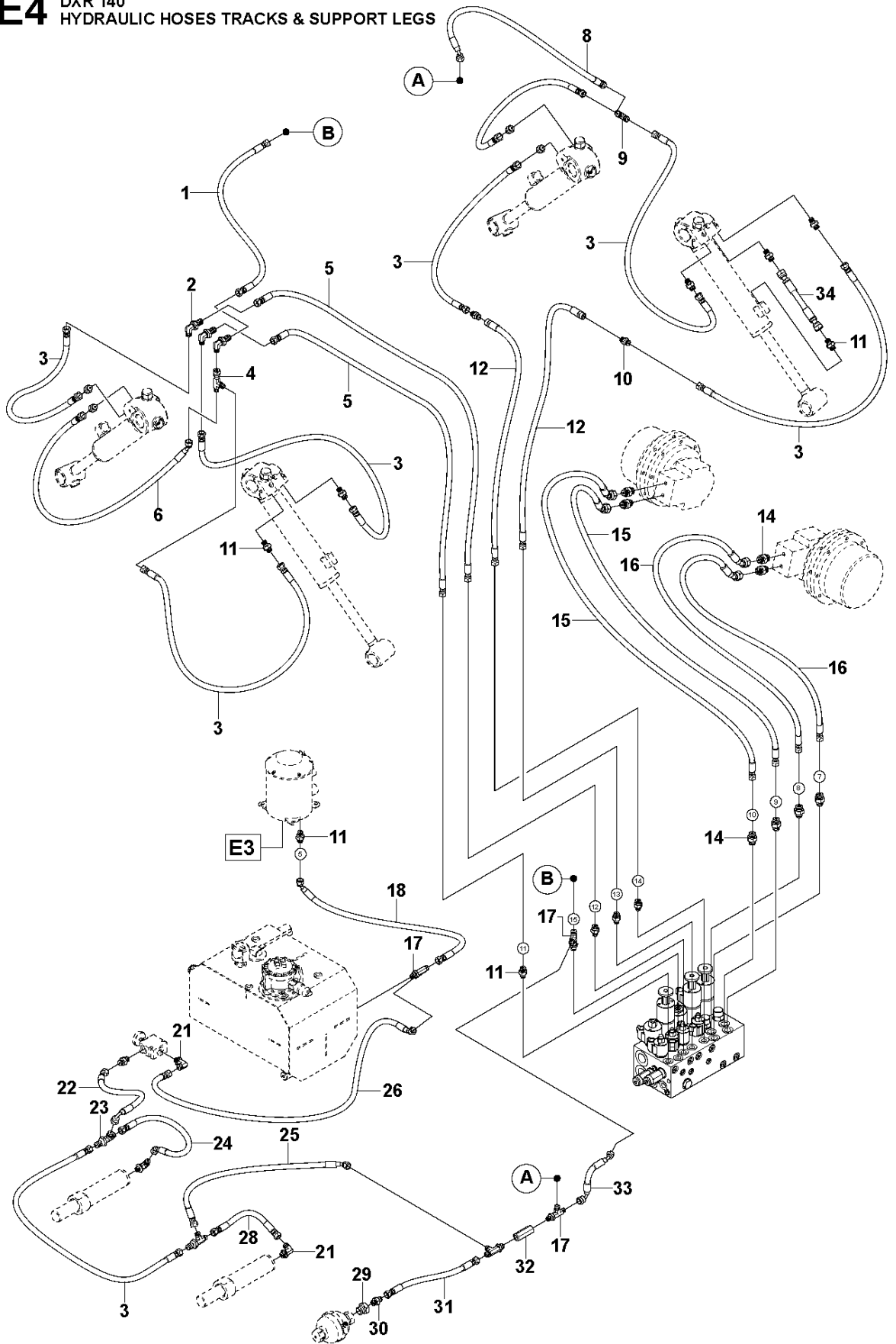

## HYDRAULIC HOSES TRACKS &amp; SUPPORT LEGS DXR140, Valid for machine 1 to 254, 2019-06

Ref	Part No	Description	Remark	QTY KIT
1	522 67 25-16	HOSE ASSY		1
2	589 00 92-01	ADAPTER		3
3	510 25 18-23	HOSE ASSY		2
4	514 37 35-01	ADAPTER		1
5	585 48 42-08	HOSE ASSY		1
6	585 48 55-01	HOSE ASSY		1
8	585 48 56-03	HOSE ASSY		1
9	510 24 73-01	ADAPTER		2
10	576 12 55-01	ADAPTER	Valid for machine S/N 1-254	4
11	510 24 57-01	ADAPTER		19
12	588 98 70-01	HOSE ASSY		2
14	510 24 58-01	ADAPTER		4
15	585 49 93-03	HOSE ASSY		2
16	585 49 93-04	HOSE ASSY		2
17	589 00 99-01	ADAPTER		1
18	510 23 48-15	HOSE ASSY	"Valid for old machines with 1/4" hose "	1
18	585 49 93-05	HOSE ASSY	"Valid for new machines with 3/8" hose "	1
21	510 26 54-01	ADAPTER		1
22	574 24 34-03	HOSE ASSY		1
23	575 59 54-01	ADAPTER		2
24	575 64 99-04	HOSE ASSY		1
25	575 64 99-02	HOSE ASSY		1
26	575 64 99-03	HOSE ASSY		1
28	510 25 18-26	HOSE ASSY		1
29	575 59 57-01	PLUG		1
30	510 24 57-01	ADAPTER		2
31	510 25 18-25	HOSE ASSY		1
32	575 59 62-01	CHECK VALVE		1
33	574 24 34-01	HOSE ASSY		1
34	585 48 42-12	HOSE ASSY		4

# F1 DXR 140 - S/N: 1-121 ELECTRICAL

38

25008553-3 P1int 32

1	2	3	4	5	6	7	8	9
10	11	12	13	14	15	16	17	18
19	20	21	22	23	24	25	26	27

22: K2-Steckp

K2	K3	K4	K5	K6	K7				
----	----	----	----	----	----	--	--	--	--

F2	F3	F4	F5
----	----	----	----

-S2	#	#	#
-T1	-T2	-T3	-S1
-K6	-Q1	-QM1_1	-QM1_2
-B1	-B2	-F1	-K1

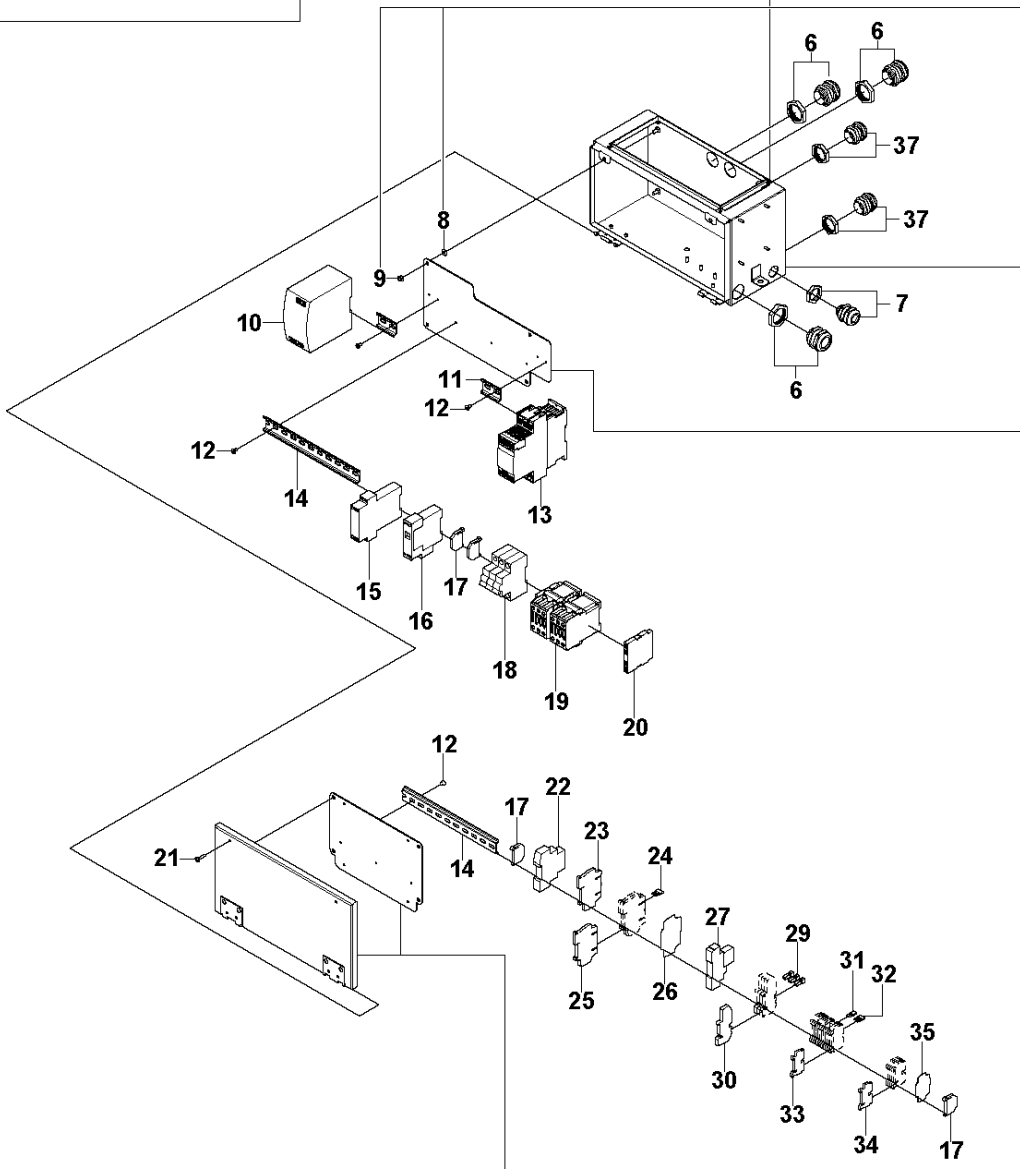
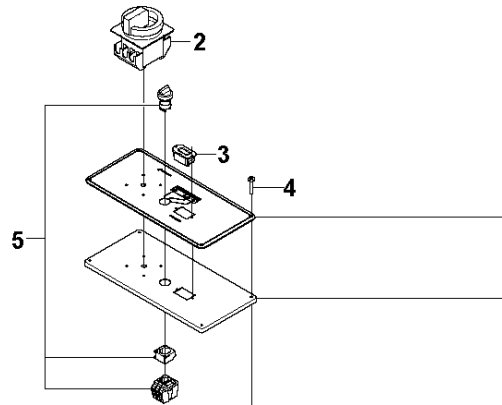

Ref	Part No	Description	Remark	QTY	KIT
1	576 29 46-01	BOX		1	
2	522 87 14-01	MAIN SWITCH		1	
3	510 28 49-01	HOUR METER		1	
4	725 23 33-51	SCREW EHHM		4	
5	575 88 81-01	SWITCH		1	
6	523 05 74-01	CABLE		3	
7	523 05 75-01	CABLE		1	
8	576 29 40-01	WASHER		8	1
9	576 29 36-01	NUT		8	1
10	505 52 74-01	TRANSFORMER	T1	1	
11	523 05 53-04	RAIL		2	
12	576 29 32-01	SCREW IHSCM		10	
13	525 51 31-01	STARTER	T2, Soft starter	1	
14	523 05 53-05	RAIL		2	
15	522 91 16-01	RELAY	B1, Safety relay	1	
16	522 86 92-01	RELAY	K1, Phase sequence relay	1	
17	522 92 21-01	STOP		4	
18	522 91 18-01	FUSE		1	
19	525 51 30-01	CONTACTOR		1	
20	576 71 61-01	RELAY	Auxiliary relay	1	
21	725 23 29-71	SCREW EHHM		2	
22	575 46 49-02	CONTROL	T3, Fan control relay	1	
23	522 92 25-01	RELAY		1	
24	575 89 44-01	BAR		1	
25	575 88 78-01	RELAY	K2, K3, K4, K5, K7	3	
26	575 89 49-01	PLATE		1	
27	575 88 91-01	RELAY	K6, Start relay	1	
29	575 89 42-01	JUMPER BAR		3	
30	522 92 18-01	FUSE HOLDER		4	
31	575 89 45-01	JUMPER BAR		1	
32	575 89 46-01	JUMPER BAR		1	
33	575 88 79-01	TERMINAL BLOCK		9	
34	575 88 80-01	TERMINAL BLOCK		5	
35	522 92 65-01	TERMINAL BLOCK		5	
37	523 05 73-01	CABLE		1	
38	588 18 09-01	STICKER		1	

**F1** DXR 140 - S/N: 122-367  
ELECTRICAL

43

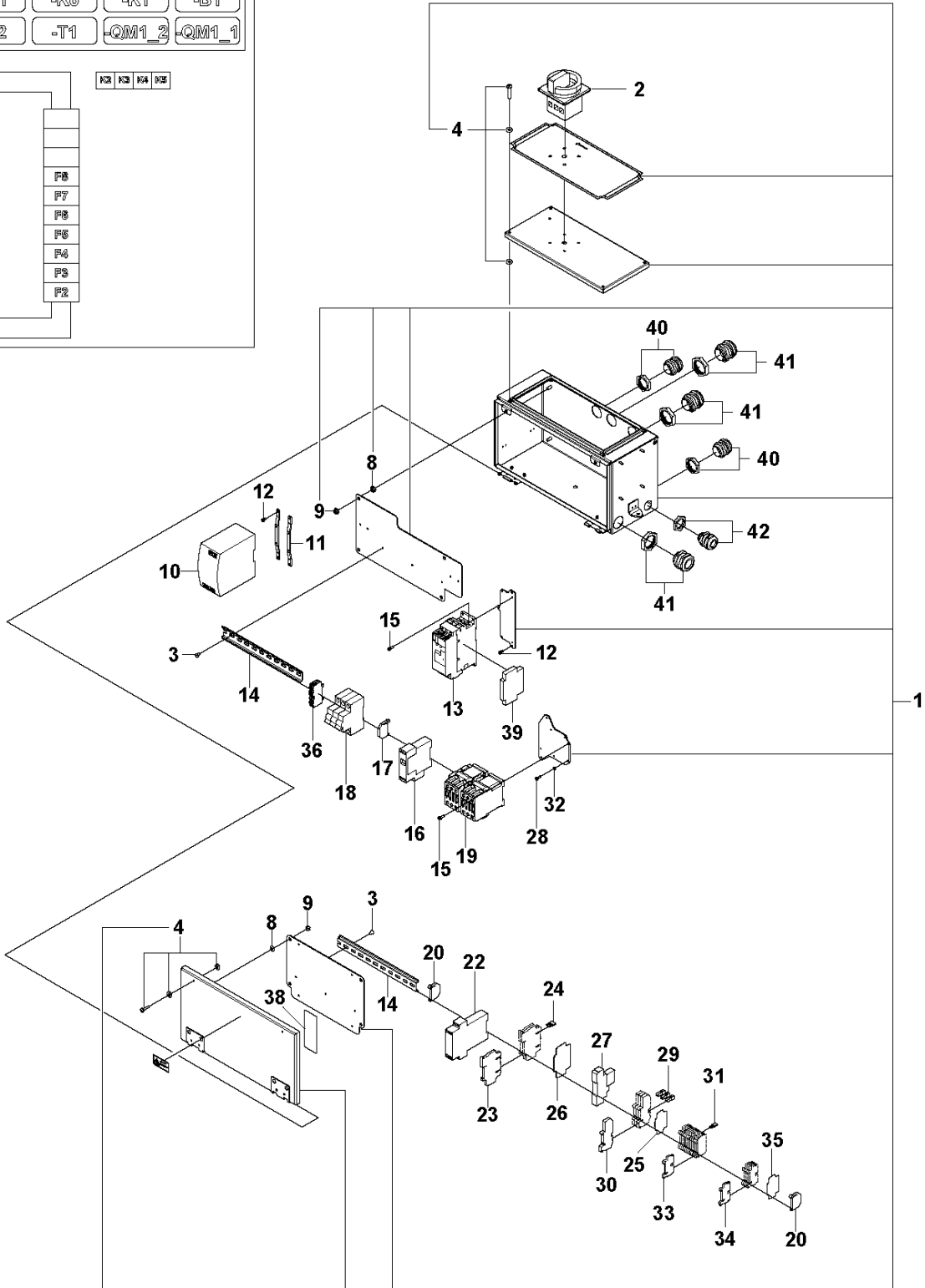
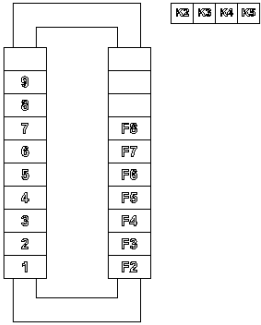
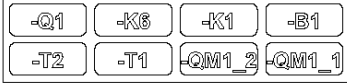

Ref	Part No	Description	Remark	QTY	KIT
1	584 81 04-01	ELECTRONIC BOX		1	
2	522 87 14-01	MAIN SWITCH		1	
3	581 31 05-01	SCREW IH PANM		11	
4	TBD	TBD		4	1
8	576 29 40-01	WASHER		8	1
9	576 29 36-01	NUT		8	1
10	505 52 74-01	TRANSFORMER	T1	1	
11	581 28 66-01	BRACKET		2	
12	725 52 87-01	SCREW IHSCM		4	
13	577 97 79-01	STARTER	T2, Soft starter	1	
14	523 05 53-05	RAIL	250mm	1	
14	523 05 53-08	RAIL	100mm	1	
15	585 27 89-01	SCREW IHSCFM		4	
16	522 86 92-01	RELAY	K1, Phase sequence relay	1	
17	522 92 21-01	STOP		1	
18	522 91 18-01	FUSE		1	
19	584 80 52-01	CONTACTOR		1	
20	584 82 16-01	TERMINAL BLOCK		2	
22	584 82 54-01	RELAY	B1, Safety relay	1	
23	522 92 25-01	RELAY	K2, K3, K4, K5	4	
24	575 89 44-01	BAR		1	
25	584 82 12-01	TERMINAL BLOCK		1	
26	575 89 49-01	PLATE		1	
27	575 88 88-01	RELAY	K6, Start relay	1	
28	725 52 89-01	SCREW IHSCM		4	
29	584 81 95-01	TERMINAL BLOCK		2	
30	584 80 60-01	FUSE HOLDER		7	
31	584 81 00-01	TERMINAL BLOCK		1	
32	585 27 84-01	WASHER		4	
33	584 80 57-01	TERMINAL BLOCK		7	
34	584 85 32-01	TERMINAL BLOCK		2	
35	584 85 35-01	TERMINAL BLOCK		1	
36	579 70 53-01	TERMINAL BLOCK		2	
38	580 36 71-01	STICKER		1	
39	577 97 80-01	RELAY	Aux relay, Soft starter	1	
40	523 05 73-01	CABLE		2	
41	523 05 74-01	CABLE		3	
42	523 05 75-01	CABLE		1	
43	588 18 10-01	STICKER	Label kit	1	

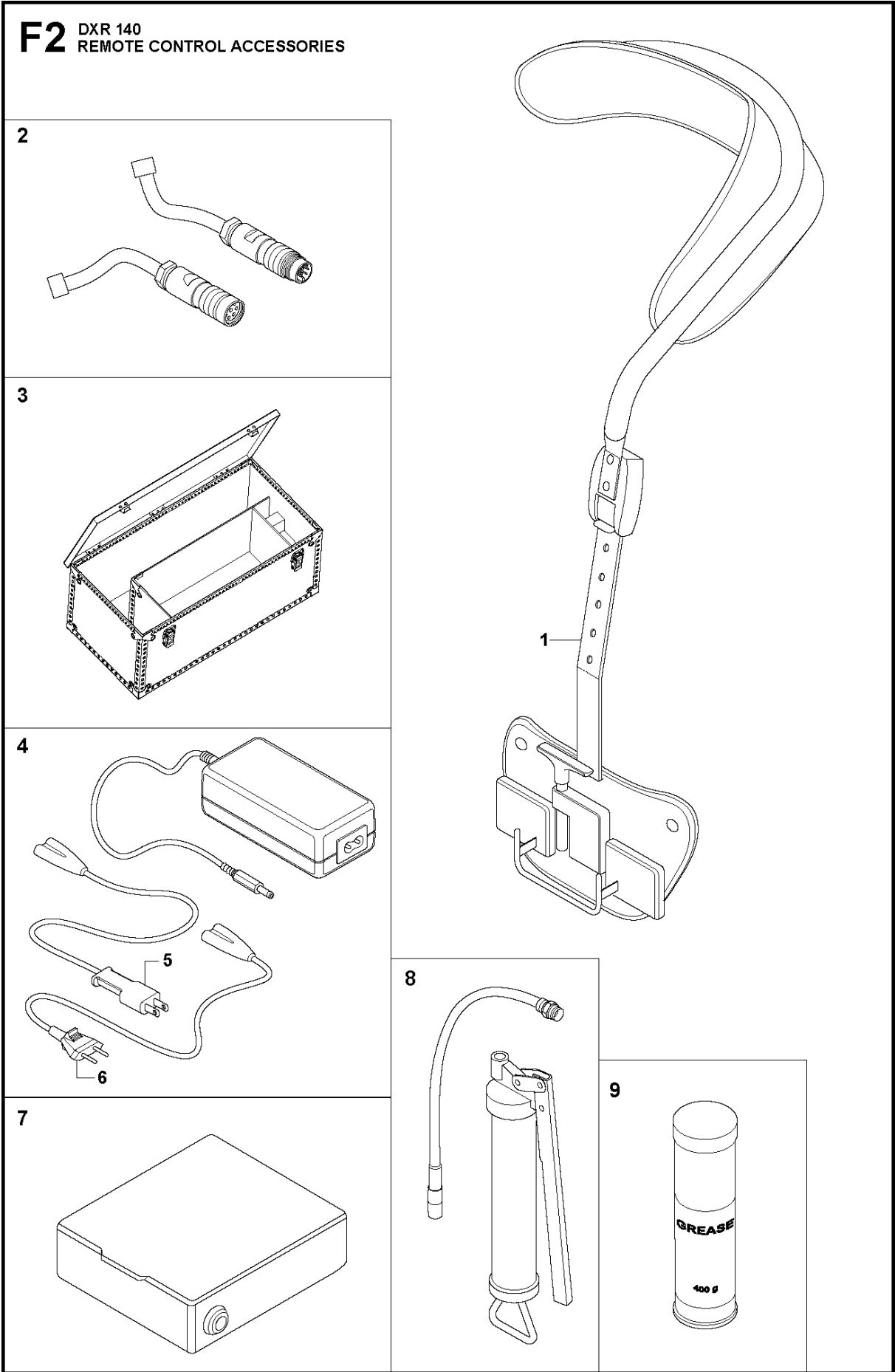



REMOTE CONTROL ACCESSORIES

DXR140, Valid for machine 1 to 254, 2019-06

Ref	Part No	Description	Remark	QTY KIT	
1	501 79 30-01	HARNES		1	
2	510 28 20-01	CABLE		1	
3	525 74 75-01	PACKING		1	
4	510 28 50-03	CHARGER		1	
5	510 28 07-02	CABLE	US cable	1	4
6	510 28 07-01	CABLE	EU cable	1	4
7	587 31 16-01	BATTERY		1	
8	506 38 49-02	GUN		1	
9	588 81 48-01	GREASE		1	

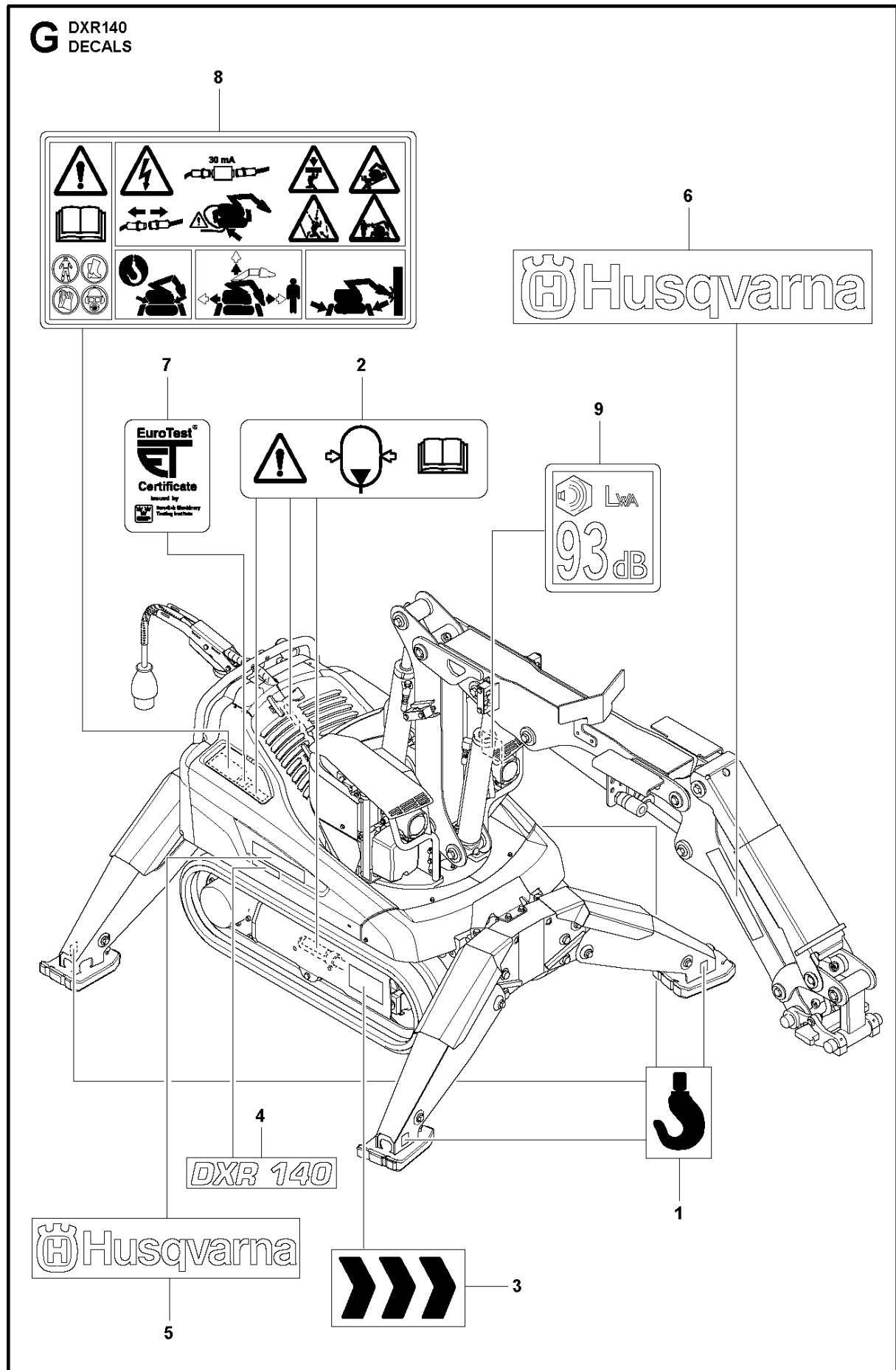

## DECALS

DXR140, Valid for machine 1 to 254, 2019-06

Ref	Part No	Description	Remark	QTY KIT
1	525 51 27-01	STICKER		4
2	596 88 34-01	STICKER		3
3	573 96 56-01	STICKER		2
4	575 34 82-01	STICKER		2
5	577 46 90-01	DECAL		2
6	588 77 84-02	STICKER		2
7	575 58 66-01	DECAL		1
8	523 02 17-01	STICKER		1
9	525 84 50-03	DECAL		1

**H** DXR140  
SCHIMS

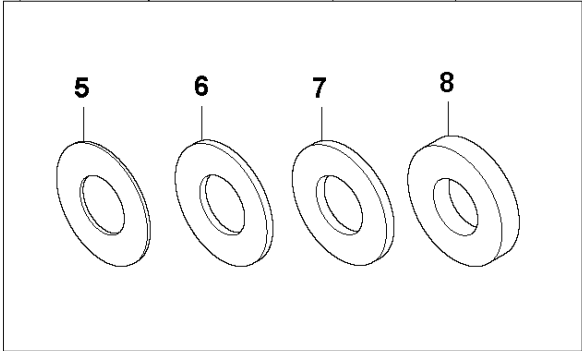
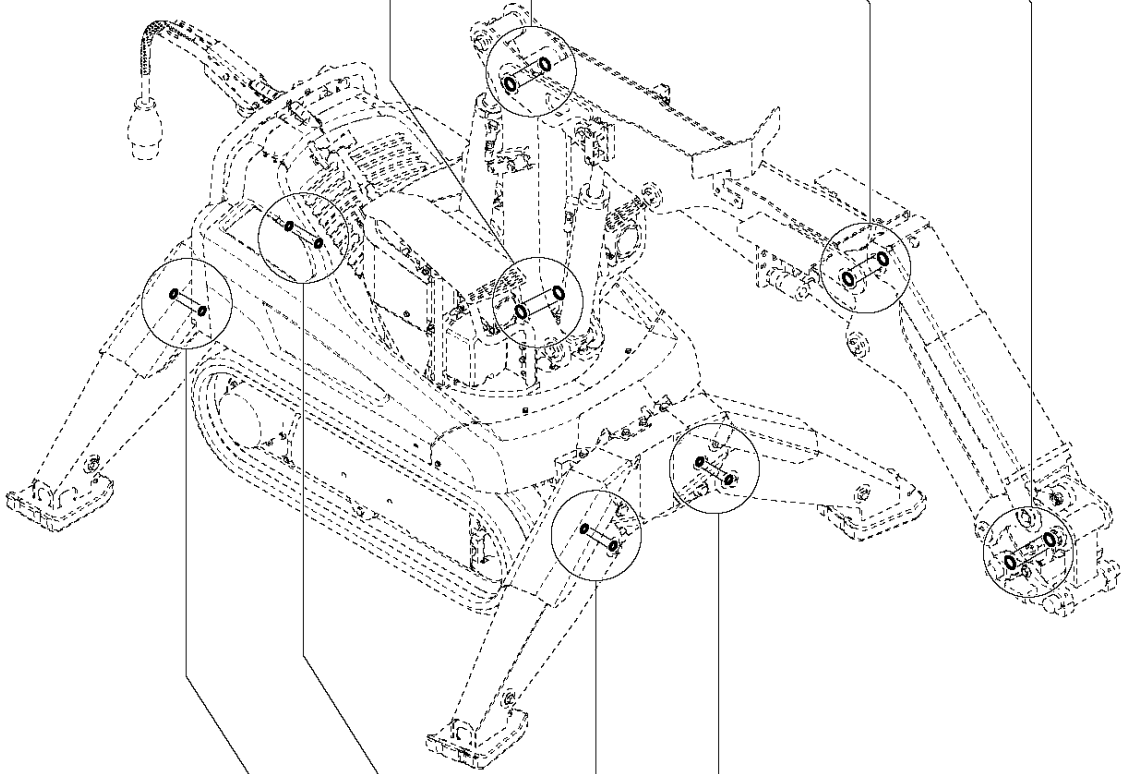
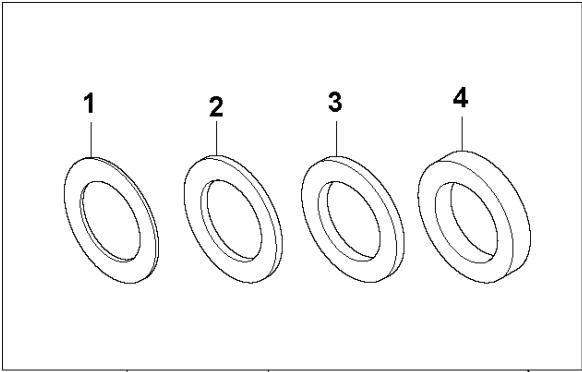

Ref	Part No	Description	Remark	QTY KIT
1	505 00 36-01	SPACER	I.D. 40mm, 0,2mm	0
2	505 00 36-02	SPACER	I.D. 40mm, 0,3mm	0
3	505 00 36-03	SPACER	I.D. 40mm, 0,5mm	0
4	505 00 36-04	SPACER	I.D. 40mm, 1,0mm	0
5	573 96 55-01	SPACER	I.D. 30mm, 0,2mm	0
6	573 96 55-02	SPACER	I.D. 30mm, 0,3mm	0
7	573 96 55-03	SPACER	I.D. 30mm, 0,5mm	0
8	573 96 55-04	SPACER	I.D. 30mm, 1,0mm	0

**J** DXR140  
WIRING HARNESS

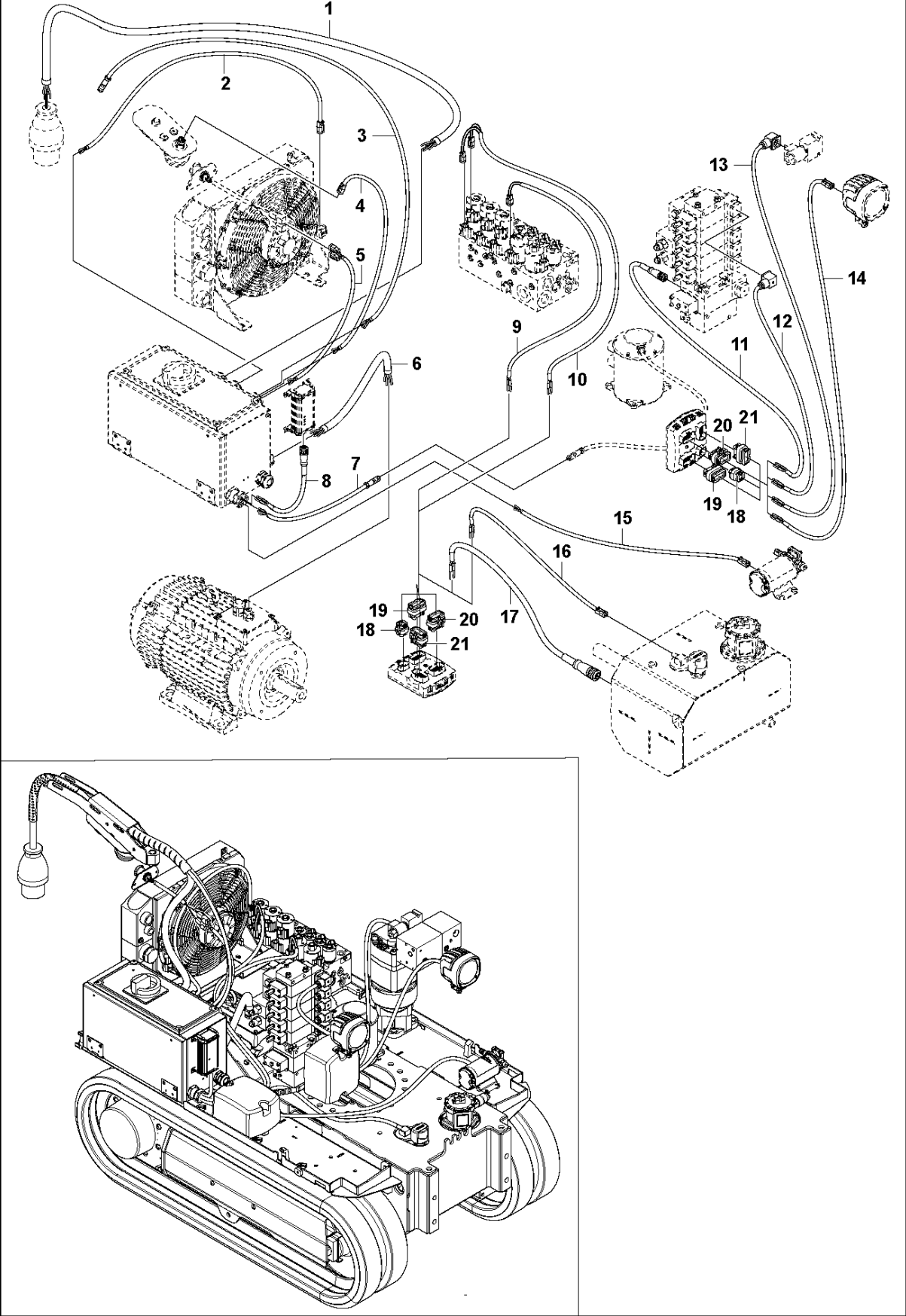

## WIRING HARNESS

DXR140, Valid for machine 1 to 254, 2019-06

Ref	Part No	Description	Remark	QTY KIT
1	586 62 43-01	CABLE ASSY	W1, Incoming power 400/460VAC	1
2	586 74 80-01	CABLE ASSY	W5, Cooling fan	1
3	593 84 01-02	CABLE ASSY	W42, Comm. to R/C	1
4	586 74 75-01	CABLE ASSY	W3, Warning light	1
5	586 61 64-01	CABLE ASSY	W7, Emergency stop	1
6	586 75 29-01	CABLE ASSY	W2, Outgoing power electric motor	1
7	586 75 47-01	CABLE ASSY	W43, CAN comm.to swivel	1
8	586 75 18-01	CABLE ASSY	W41, Bluetooth radio	1
9	579 67 41-01	CABLE ASSY	W10-15, Circulation valve, Outrigger On/Off, Pressure 6 Control	6
10	579 67 47-01	CABLE ASSY	W16-18, Tracks, Outriggers prop.	3
11	586 75 10-01	CABLE ASSY	W33, Oil pressure sensor	1
12	576 61 44-02	CABLE	W20-25, Tool, rotation, cylinder 1-4, extra 1 & 2	7
13	586 74 87-01	CABLE ASSY	W30, Grease pump	1
14	586 75 09-01	CABLE ASSY	W31-32, Work lights	2
15	579 67 40-01	CABLE ASSY	W6, Oil filling pump	1
16	586 75 45-01	CABLE ASSY	W38, Oil level sensor	1
17	586 75 15-01	CABLE ASSY	W36, Oil temp. sensor	1
18	522 92 74-01	CONNECTOR	8-way, black	1
19	522 92 75-01	CONNECTOR HOUSING	23 way, grey	1
20	522 92 75-02	CONNECTOR HOUSING	23 way, blue	1
21	522 92 75-03	CONNECTOR HOUSING	23 way, black	1

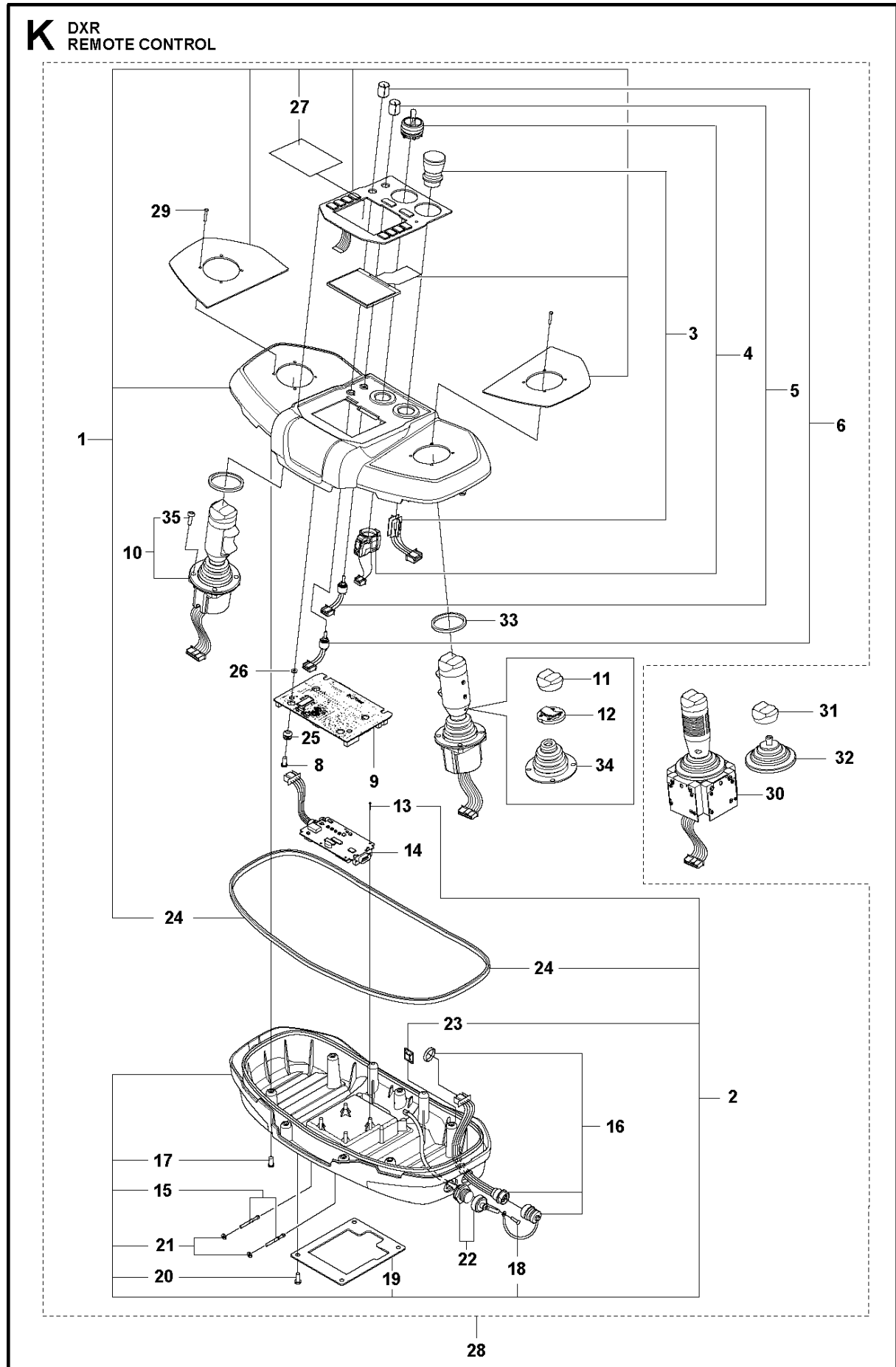



REMOTE CONTROL

DXR140, Valid for machine 1 to 254, 2019-06

Ref	Part No	Description	Remark	QTY	KIT
1	587 36 11-01	COVER KIT		1	28
2	587 36 61-01	COVER KIT		1	28
3	510 36 33-01	SWITCH	Machine stop	1	28
4	510 36 35-01	SWITCH	Main switch, ON/OFF	1	28
5	522 96 66-01	POTENTIOMETER	Tool	1	28
6	522 96 65-01	POTENTIOMETER	Machine	1	28
8	522 66 89-01	SCREW CRPANT		4	28
9	510 21 73-07	CONTROL BOARD	No firmware installed	1	28
10	582 45 09-01	JOYSTICK		1	28
11	582 42 18-01	PROTECTION		1	10, 28
12	582 42 10-01	BUTTON KIT		1	10, 28
13	522 79 66-01	SCREW CCRPANT		4	2,28
14	510 21 78-01	CONTROL BOARD	Bluetooth	1	28
15	510 22 26-01	SPRING PIN		2	2,28
16	522 96 67-01	CONNECTION	Communication cable	1	28
17	503 21 74-16	SCREW IHCT		9	2,28
18	523 00 50-01	SCREW CRPANT		1	2,28
19	510 10 85-01	PLATE		1	2,28
20	586 18 79-01	SCREW CRPANT		4	2,28
21	734 11 24-01	WASHER		1	2,28
22	586 14 66-01	CONTACT	USB	1	28
23	577 96 36-01	CABLE HOLDER		1	2,28
24	576 88 80-05	SEALING STRIP		1	1,2,28
25	510 21 76-01	BUSHING		1	28
26	734 11 36-60	WASHER		1	28
27	585 30 68-01	PROTECTION		1	1,28
28	585 16 11-01	REMOTE CONTROL		1	
29	582 42 06-02	SCREW		1	28
30	510 21 40-01	JOYSTICK	LEFT	1	
30	510 21 40-02	JOYSTICK	RIGHT	1	
31	576 63 31-01	SEAL		2	30
32	576 63 32-01	SEAL		2	30
33	589 75 28-01	WASHER		1	28
34	597 68 78-01	BELLOWS		2	10, 28
35	582 42 06-02	SCREW		8	10, 28