

WS 462

Reservdelar

Spare parts

Ersatzteile

Pieces de rechange

Piezas de repuesto

Ricambi

Peças sobresselente

No.	Pos.	Description	No.	Pos.	Description
501 37 29-01	M	Outer side Right 800mm compl.	531 11 33-03	G	Saw carriage complete
501 37 30-01	M	Outer side Left 800mm compl.	531 11 73-43	L	Potentiometer knob
501 37 31-01	M	Outer side Right 1000mm compl.	531 11 80-03	Q	Quick coupling 1800UV female
501 37 32-01	M	Outer side Left 1000mm compl.	531 11 80-05	Q	Nipple 1812
501 37 33-01	M	Outer side Right 1240mm compl.	531 11 80-06	Q	Quick coupling 18210 male
501 37 34-01	M	Outer side Left 1240mm compl.	531 11 80-18	Q	Ball valve
501 37 52-01	P	Tool kit	531 11 80-41	F	Hydraulic coupling 1/2" female
504 00 50-01	M	Flush bladeguard 800mm compl.	531 11 80-42	F	Hydraulic coupling 1/2" male
504 00 52-01	M	Flush bladeguard 1000mm cpl.	531 11 80-45	B	Hydraulic coupling 1/8" female
504 00 53-01	M	Flush bladeguard 1240mm cpl.	531 11 80-46	B	Hydraulic coupling 1/8" male
504 05 86-01	P	Husqvarna oil 150 1dl	531 11 81-13	D	Magnetic plug
504 10 02-01	J	Scale	531 11 81-92	Q	Water hose
504 10 29-01	P	Toolbag	531 11 81-95	B	Tooth wheel set
505 11 30-01	K	Excentric	531 11 81-96	B	Tooth wheel set
505 11 31-01	K	Handle bracket	531 11 81-98	B	Driving shaft
505 11 33-01	K	Beam	531 11 82-18	EQ	Quick coupling, male 13411 M
505 11 34-01	K	Snap locking	531 11 82-19	Q	Quick coupling 1300UV female
505 11 35-01	K	Hook	531 11 83-18	Q	Hose 0,45m
505 11 37-01	K	Handle holder	531 11 83-25	Q	Nipple 1312
505 11 38-01	K	Handle	531 11 83-37	B	Adapter 1/8"
505 11 39-01	K	Shaft seat	531 11 90-14	Q	Hose clamp 13-20
505 11 40-01	K	Spring	531 11 90-15	Q	Hose clamp 15-24
505 11 40-01	K	Spring	531 11 90-39	C	Bearing washer AS 3552
505 11 99-01	L	Tube	531 11 90-42	C	Bearing AXK 3552
505 12 00-01	L	Bracket	531 11 90-45	F	Ball D20xM5
505 12 02-01	L	Cone	531 11 90-63	A	Grease nipple
505 12 03-01	L	Cone	531 11 90-65	P	Wrench 18 mm
505 12 04-01	L	Shaft	531 11 90-98	F	Spring LBR 45F
505 12 05-01	L	Locking plate	531 11 90-99	F	Ball 6 mm
505 12 06-01	L	Locking plate	531 11 91-08	P	Grease gun
505 12 07-01	L	Locking stop	531 11 91-45	B	Washer, copper
505 12 08-01	L	Locking stop	531 11 91-46	BG	Bearing washer
505 12 09-01	L	Cone	531 11 91-49	BFG	Bearing AXK 1024
505 12 10-01	L	Washer	531 11 91-50	B	Bearing
505 15 29-01	L	Blade guard D800mm Assy	531 11 91-52	H	Plug
505 15 30-01	L	Blade guard D1000mm Assy	531 11 91-55	B	Bearing Nk 19/16
505 15 31-01	L	Blade guard D1240mm Assy	531 11 91-58	B	Shim 23.35x1
505 18 64-01	K	Parallell pin	531 11 91-65	LM	Blind rivet 4x12 st/st
505 18 65-01	K	Screw	531 11 91-81	K	Washer 10.5x22
505 18 66-01	K	Stop screw	531 11 91-83	DHJ	Washer 13x24x2
505 18 74-01	K	Blade guard guide	531 11 91-85	DF	Sealing ring 1/2"
505 21 61-01	E	Flange, inner	531 11 91-88	B	Radial seal GHH2 28x20,5x3,2
505 21 62-01	E	Hub	531 11 92-02	EH	Screw M6S 12x25
505 21 64-01	E	Radial seal 50x62x7 RF	531 11 92-03	HJ	Screw M6S 12x30
505 21 65-01	E	Lock ring SGA 50	531 11 92-18	M	Screw M6S 8x25
505 21 76-01	E	Blade flange compl.	531 11 92-28	BD	Screw MC6S 5x14
505 21 76-02	E	Blade flange 60mm compl.	531 11 92-35	H	Screw MC6S 8x14
505 21 80-01	E	Flange, inner 130	531 11 92-60	L	Washer 5x19x1
505 21 81-01	E	Blade flange 130 compl.	531 11 92-62	F	O-ring 18,3x2,4
531 11 30-37	Q	Water hose with valve	531 11 92-70	F	O-ring 24,2x3
531 11 30-45	H	Track 1,2m complete	531 11 92-74	D	O-ring 29,2x3
531 11 30-46	H	Track 2,0m complete	531 11 92-77	B	O-ring 31,4x1,6
531 11 30-47	H	Track 2,2m complete	531 11 92-80	B	O-ring 43x1,6
531 11 30-78	F	Shaft seal set	531 11 92-90	E	O-ring 61,6x2,4
531 11 31-69	B	Worm gear + comm. valve 50:1	531 11 92-93	F	O-ring 80x1,6
531 11 32-00	J	Mounting bracket universal	531 11 93-07	C	Key 6x6x14
531 11 32-44	D	Pivoting arm compl.	531 11 93-19	F	Shaft seal SCN 18x30x6
531 11 32-46	H	Mounting bracket complete	531 11 93-26	N	Washer
531 11 32-47	H	Coupling link complete	531 11 93-39	F	Plug VSTI M14X1,5
531 11 32-48	H	Track holder complete	531 11 93-40	F	Plug VSTI R1/2
531 11 32-51	B	Motor bracket complete	531 11 93-50	H	Screw MF6S 4x12 12.9
531 11 32-52	B	Feeding motor, track feed	531 11 93-53	M	Screw MLC6S 6x12
531 11 32-54	B	Feeding motor, down feed	531 11 93-60	D	O-ring 133,0x1,78
531 11 32-57	F	Hydraulic motor compl. WS 462	531 11 93-64	DJ	Spring
531 11 32-58	G	Guide wheel concentric compl.	531 11 93-75	C	X-Ring 114,0x1,78
531 11 32-59	G	Guide wheel excentric compl.	531 11 93-76	C	O-Ring 94,97x1,78
531 11 32-65	J	Measure rod complete	531 11 94-13	LM	Handle Bladeguard
531 11 32-66	F	Hydraulic motor WS 462	531 11 94-18	J	Screw M6S 12x120
531 11 32-68	Q	Cleaning brush complete	531 11 94-20	J	O-ring 40x2
531 11 32-71	C	Clutch trackfeeding compl.	531 11 94-26	GMN	Screw K6S 6x16 10.9 fzb

No.	Pos.	Description	No.	Pos.	Description
531 11 94-32	N	Plug	531 12 23-85	N	Bar
531 11 94-39	C	Bearing HK 3520	531 12 23-88	N	Cramp
531 11 94-40	C	Washer AS 5070	531 12 23-90	N	Guide plate
531 11 94-41	D	Bearing 16005	531 12 24-54	J	Mounting bracket
531 11 94-42	G	Bearing 6001-2RSH	531 12 24-55	J	Shaft
531 11 94-43	C	Bearing 16007	531 12 24-56	J	Link to track-holder
531 11 94-44	D	Bearing 61909-2RS1	531 12 24-57	J	Track holder
531 11 94-45	D	Bearing 61816	531 12 24-58	J	Clamping plate
531 11 94-47	D	Shaft seal BA 50x65x7	531 12 24-59	J	Clamping plate nut
531 11 94-48	D	O-ring 101,34x1,78	531 12 24-60	J	Breaking plate
531 11 94-51	D	O-ring 74,5x3	531 12 30-00	A	House
531 11 94-53	G	Levell	531 12 30-01	G	Saw carriage
531 11 94-54	G	Spring	531 12 30-02	G	Socket
531 11 94-56	H	Knob	531 12 30-03	G	Holder right
531 11 94-57	G	Bearing bushing	531 12 30-04	G	Holder left
531 11 94-99	D	O-ring 69,5x3	531 12 30-05	G	Concentric shaft
531 11 95-00	C	O-ring 61x1,6	531 12 30-06	G	Excentric shaft
531 11 95-04	C	O-ring 71,12x2,62	531 12 30-07	G	Guide wheel
531 11 95-26	M	Edge list 3,3m	531 12 30-08	G	Nut for guide wheel
531 11 95-31	P	Water level	531 12 30-09	G	Handle
531 11 95-32	P	Ratchet wrench	531 12 30-10	G	Bar
531 11 95-33	P	Wrench 16mm	531 12 30-11	G	Excentric locking shaft
531 11 95-34	P	Socket 18mm	531 12 30-12	G	Locking clamp
531 11 95-35	P	Allen key 10mm	531 12 30-13	G	Sprint
531 11 95-36	P	Allen key 8mm	531 12 30-14	G	Excentric bushing
531 11 95-37	P	Allen key 6mm	531 12 30-15	G	Feeding shaft
531 11 95-38	P	Allen key 5mm	531 12 30-16	G	Shaft holder
531 11 95-39	P	Allen key 4mm	531 12 30-17	G	Transfer gear
531 11 95-40	P	Allen key 3mm	531 12 30-18	G	Nut for shaft
531 11 95-41	P	Socket 19mm	531 12 30-19	C	Arm shaft
531 11 95-53	Q	Cleaning brush	531 12 30-20	A	Wear plate
531 11 95-81	E	Bearing 61810-2RS	531 12 30-21	C	Feeding gear, arm
531 11 95-86	J	Screw MRX 3x5	531 12 30-22	C	Feeding gear, track
531 11 95-88	G	Seeger circlip SGA 11	531 12 30-23	C	Longituinal feeding gear
531 11 95-89	K	Screw K6S 6x20 10.9 fzb	531 12 30-24	C	Tensioning nut
531 11 95-96	B	O-ring 41x1	531 12 30-25	C	Cup spring
531 11 96-01	D	Shaft seal BASL 25x35x7	531 12 30-26	C	Friction plate
531 12 13-44	F	Support washer	531 12 30-27	G	Bushing
531 12 14-02	F	Valve lever hub	531 12 30-30	D	Input gear
531 12 14-03	F	Valve lever	531 12 30-31	D	Stub gear
531 12 16-11	M	Knob	531 12 30-32	D	Medial gear
531 12 20-27	H	Rack	531 12 30-33	E	Flange, outer
531 12 20-28	H	Rack	531 12 30-35	D	Blade shaft
531 12 20-34	B	Thrust journal	531 12 30-36	D	Cover plate
531 12 20-43	H	Guide	531 12 30-40	C	Clutch plate
531 12 20-44	H	Guide	531 12 30-41	D	Mounting plate
531 12 20-49	D	Sealing plug	531 12 30-43	D	Medial shaft
531 12 20-70	H	Safety stop	531 12 30-44	D	Medial spacer
531 12 20-85	F	Valve cover	531 12 30-46	D	Collar
531 12 20-87	F	Shift valve	531 12 30-47	D	Collar plate
531 12 21-08	B	Cover	531 12 30-48	E	60mm bushing
531 12 21-18	H	Clamping washer	531 12 30-51	E	Plate for hub
531 12 21-24	H	Rack	531 12 30-55	B	Cover plate
531 12 21-25	H	Guide	531 12 30-56	E	Water block
531 12 21-68	N	Guide	531 12 30-57	E	Water connection
531 12 21-82	K	Guide wheel shaft	531 12 30-59	LM	Rail holder
531 12 21-82	K	Guide wheel shaft, upper	531 12 30-62	A	Saw handle
531 12 21-83	K	Wheel	531 12 30-63	LM	Rail
531 12 22-43	M	Locking feather Right	531 12 30-64	K	Mount
531 12 22-44	M	Locking feather left	531 12 30-66	K	Cover
531 12 22-45	M	Lock cone	531 12 30-70	K	Handle
531 12 22-51	Q	Wear hose	531 12 30-71	K	Excentric shaft
531 12 22-60	M	Top holder	531 12 30-73	LM	Slide rail
531 12 22-80	C	Friction plate pivoting arm	531 12 30-74	P	Pin socket
531 12 23-36	F	Retracting block	531 12 30-75	H	Track holder
531 12 23-38	K	Spacer	531 12 30-76	H	Clamping plate
531 12 23-45	L	Splash guard compl.	531 12 30-77	H	Mounting bracket
531 12 23-49	L	Splash shield	531 12 30-86	LM	Rail holder 2
531 12 23-57	J	Friction plate	531 12 30-87	N	Bracket
531 12 23-58	K	Guide wheel shaft, lower	531 12 30-89	F	Valve block

No.	Pos.	Description	No.	Pos.	Description
531 12 30-91	N	Handle			
531 12 30-95	E	Water hose			
531 12 30-96	H	Coupling link			
531 12 30-97	H	Clamping washer			
531 12 31-00	B	Aluminium washer red			
531 12 31-03	B	Distance 20cc			
531 12 31-28	D	Seal for arm			
531 12 32-49	D	Arm housing			
531 14 20-25	F	Nipple 1/2"			
720 12 65-50	F	Cylindrical pin 4x6			
720 12 71-50	G	Cylindrical pin 4x18			
720 13 08-50	G	Cylindrical pin 5x16			
720 13 51-50	D	Cylindrical pin 6x16			
720 13 52-51	H	Cylindrical pin 6x18			
720 13 53-50	J	Cylindrical pin 6x20			
720 13 65-51	J	Cylindrical pin 6x50			
721 42 57-00	N	Spring pin 4x22			
721 42 58-00	F	Spring pin 4x25			
723 53 66-51	E	Screw MFS 6x12			
725 25 44-91	D	Screw M6S 12x60			
725 53 01-51	B	Screw MC6S 4x35 12.9			
725 53 41-01	K	Screw MC6S 5x50			
725 53 62-01	K	Screw MC6S M6x8			
725 53 64-01	H	Screw MC6S 6x10			
725 53 66-01	M	Screw MC6S 6x12			
725 53 68-01	GKLM	Screw MC6S 6x16			
725 53 70-01	G	Screw MC6S 6x20			
725 53 76-01	F	Screw MC6S 6x35			
725 53 78-01	F	Screw MC6S 6x40			
725 54 53-01	FG	Screw MC6S 8x25			
725 54 64-01	D	Screw MC6S 8x65			
725 62 85-01	D	Screw MF6S 4x6			
725 62 87-01	D	Screw MF6S 4x8			
725 63 27-51	AEFK	Screw MF6S 5x12 10.9			
725 63 30-51	KL	Screw MF6S 5x16 10.9			
725 63 66-51	DE	Screw MF6S 6x12 10.9			
725 63 68-51	ADKLM	Screw MF6S 6x16 10.9			
725 63 70-51	EKN	Screw MF6S 6x20 10.9			
725 64 47-51	E	Screw MF6S 8x12 10.9 fzb			
725 64 89-51	E	Screw MF6S 10x16 10.9			
728 72 89-05	C	Stop screw S6SS 4x10			
728 73 64-05	G	Stop screw S6SS 6x10			
731 43 20-01	GKN	Nut M10 low			
732 25 14-01	K	Nut M5 Nylock			
732 25 16-01	N	Nut M6			
732 25 22-71	DJ	Locking nut M12			
734 11 63-01	DFH	Washer 8.4x16			
735 31 28-10	G	Seeger circlip SGH 28			
735 31 30-10	F	Seeger circlip SGH 30			
735 31 33-00	C	Seeger circlip SGA 35			
735 31 33-10	K	Seeger circlip SGH 35			
738 21 05-00	D	Bearing			
738 21 10-04	C	Bearing 6010-2RS1			
738 22 02-24	K	Bearing 6202-2RS1 C2			
740 38 18-01	B	Sealing ring 1/8			
740 38 27-01	EQ	Sealing ring 1/4			
740 38 34-01	Q	Sealing washer 3/8"			
740 42 07-00	E	O-ring 9,1x1,6			
740 42 14-00	G	O-ring 16,1x1,6			
740 43 07-00	FH	O-ring 9,3x2,4			
740 43 09-00	BF	O-ring 11,3x2,4			
740 43 11-00	D	O-ring 13,3x2,4			
740 44 04-00	F	O-ring 19,2x3			

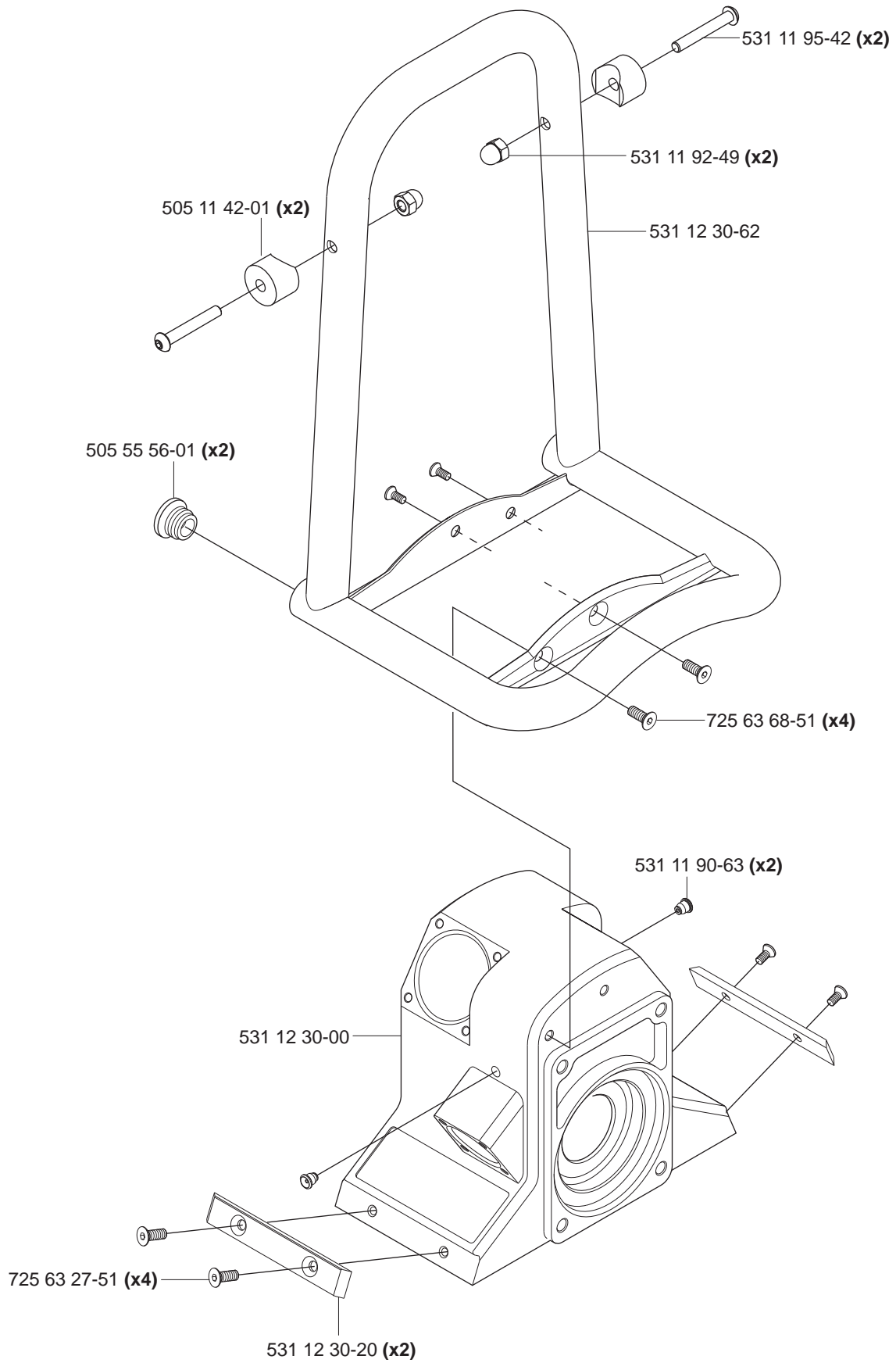

B WS 462

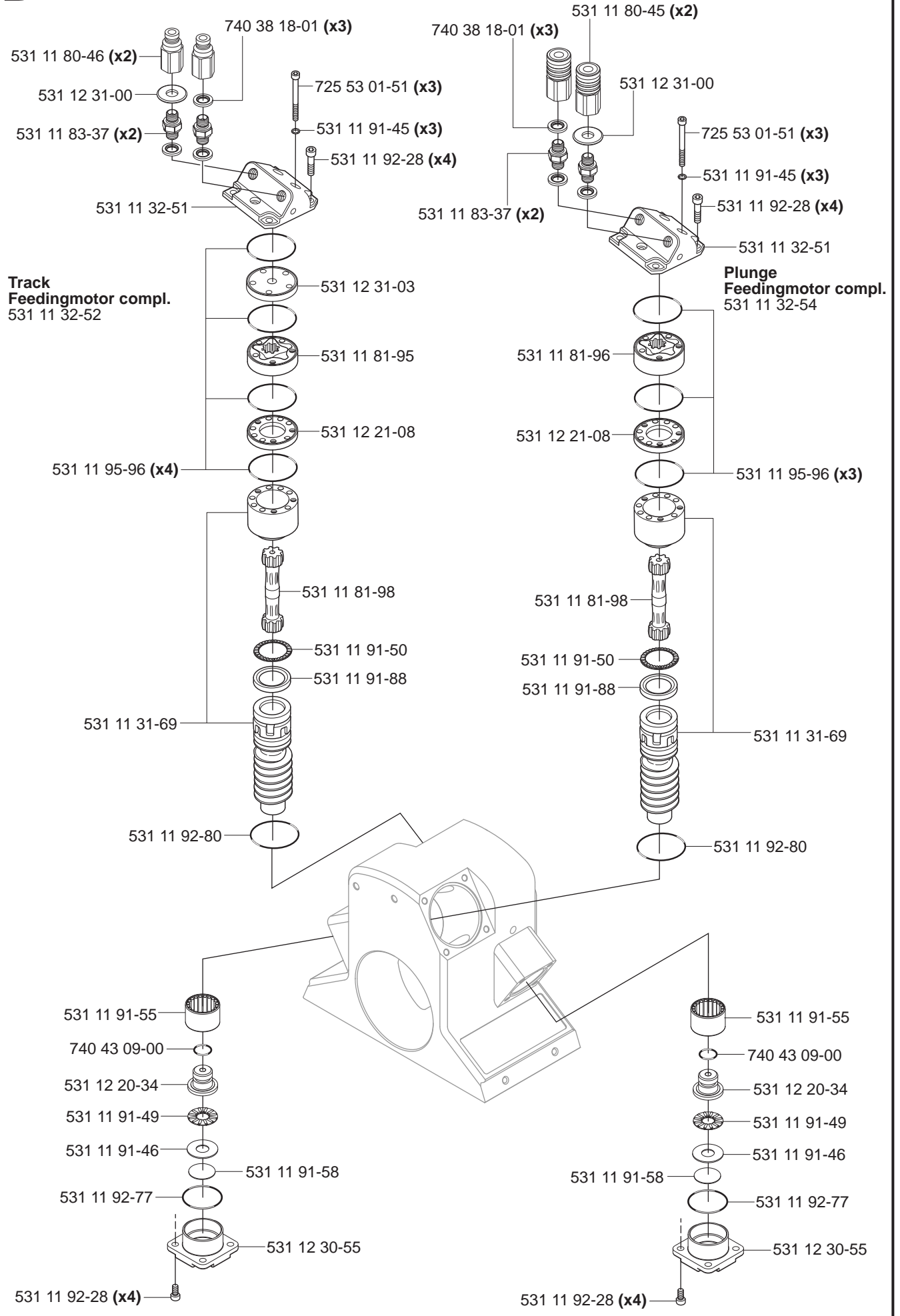

C WS 462

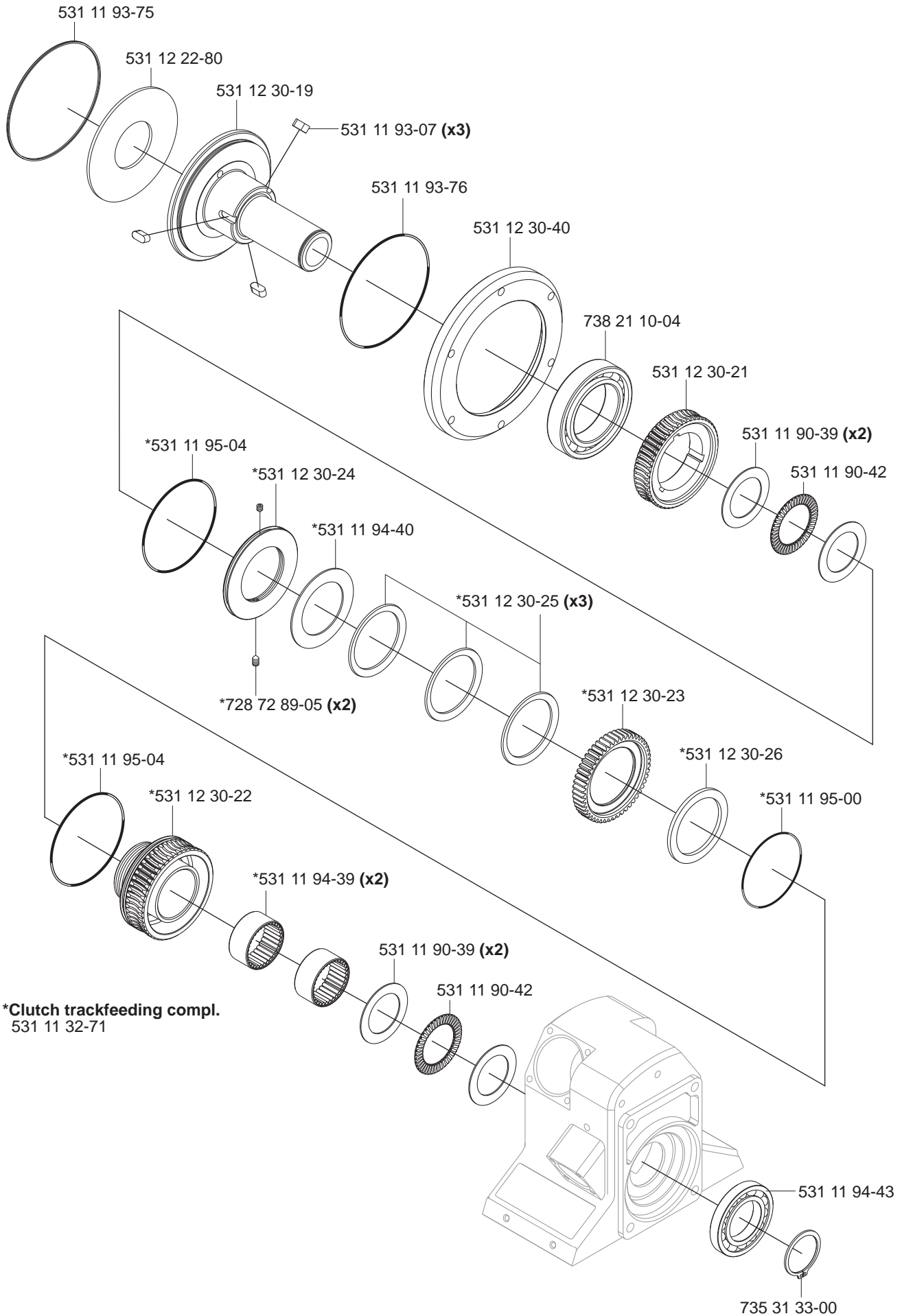

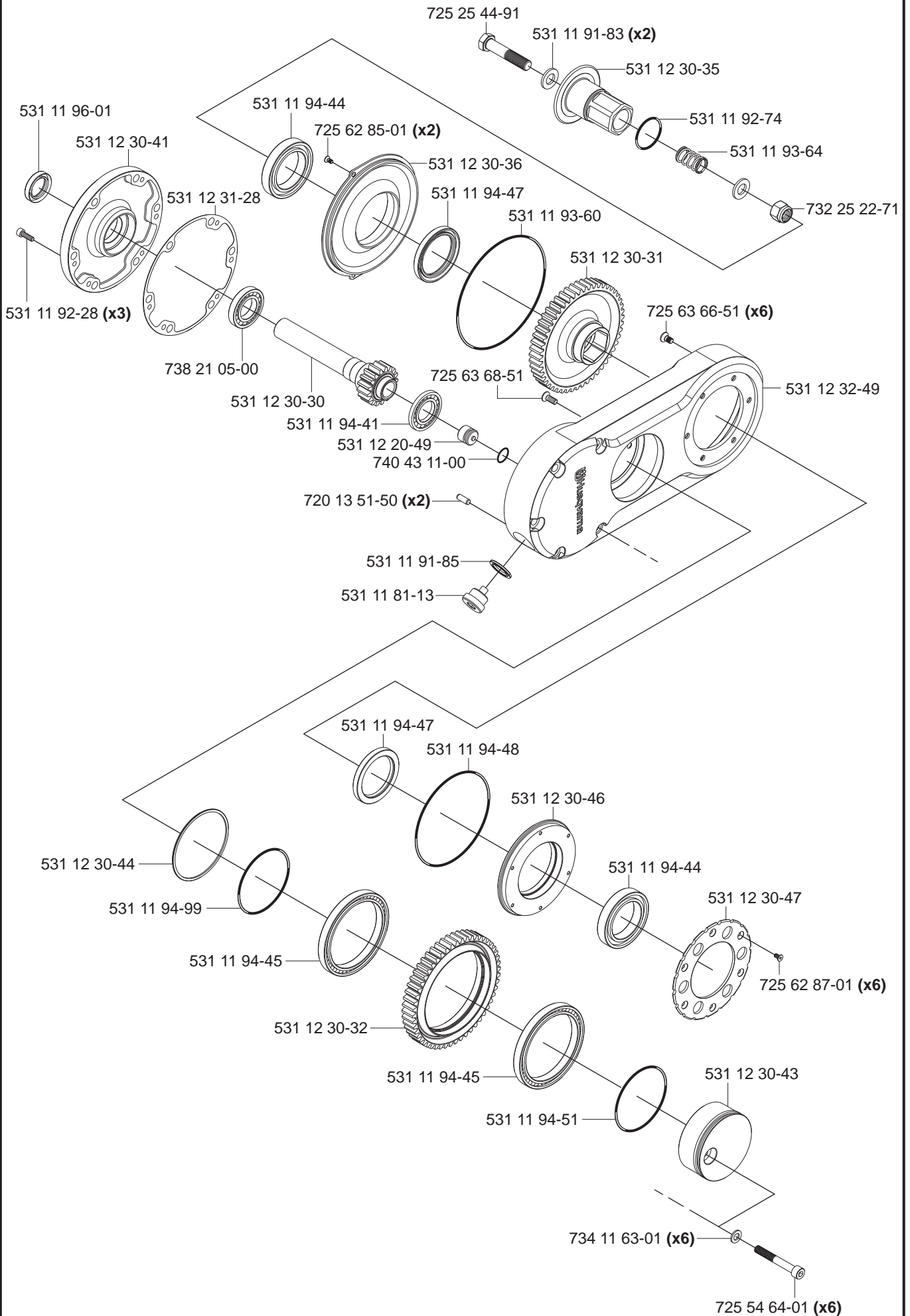
D**WS 462****Pivoting arm complete 531 11 32-44**

- Flange 1" complete** 505 21 76-01
- Flange 60mm complete** 505 21 76-02
- Flange 130 complete** 505 21 81-01

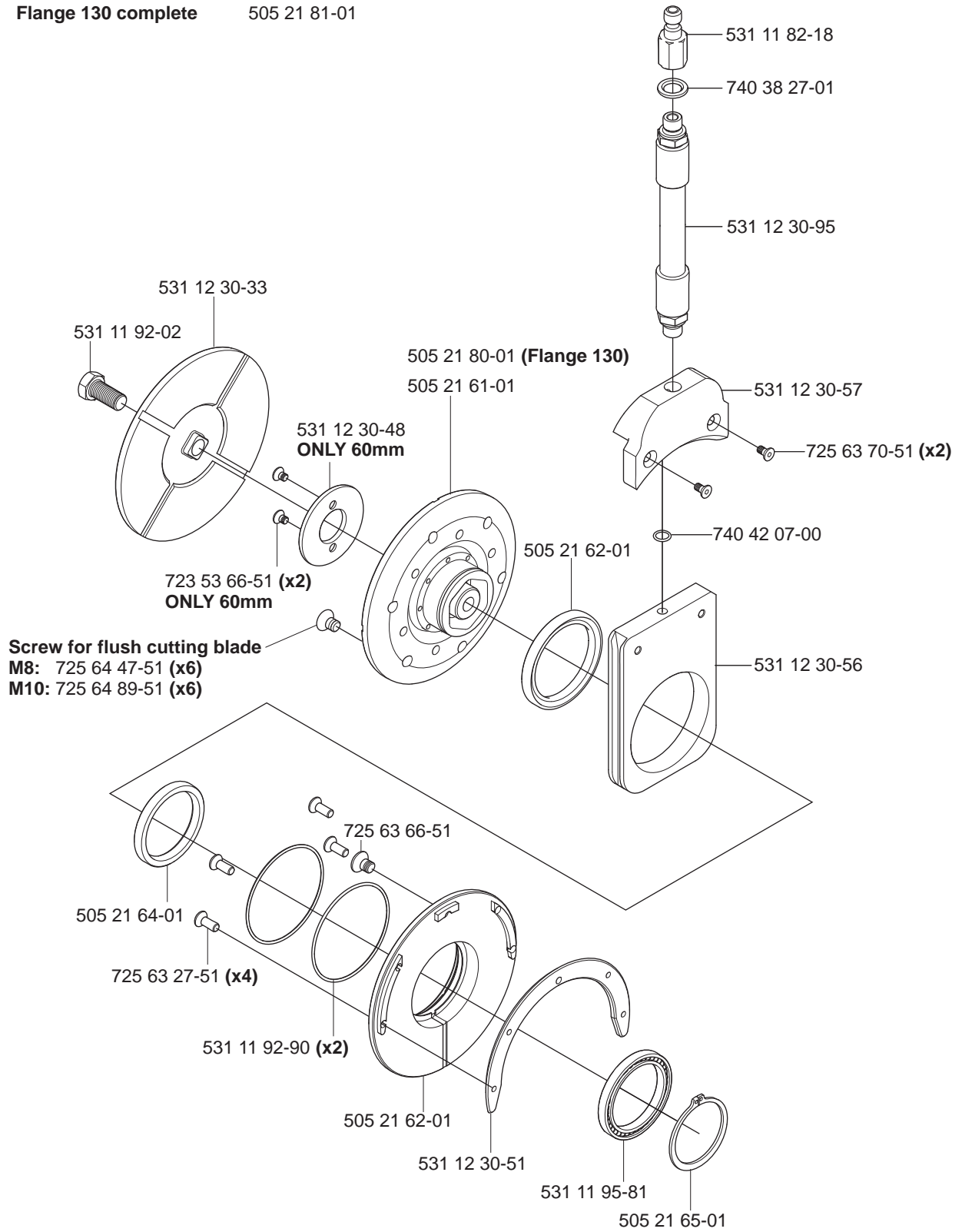

F

WS 462

Hydraulic motor complete 531 11 32-57

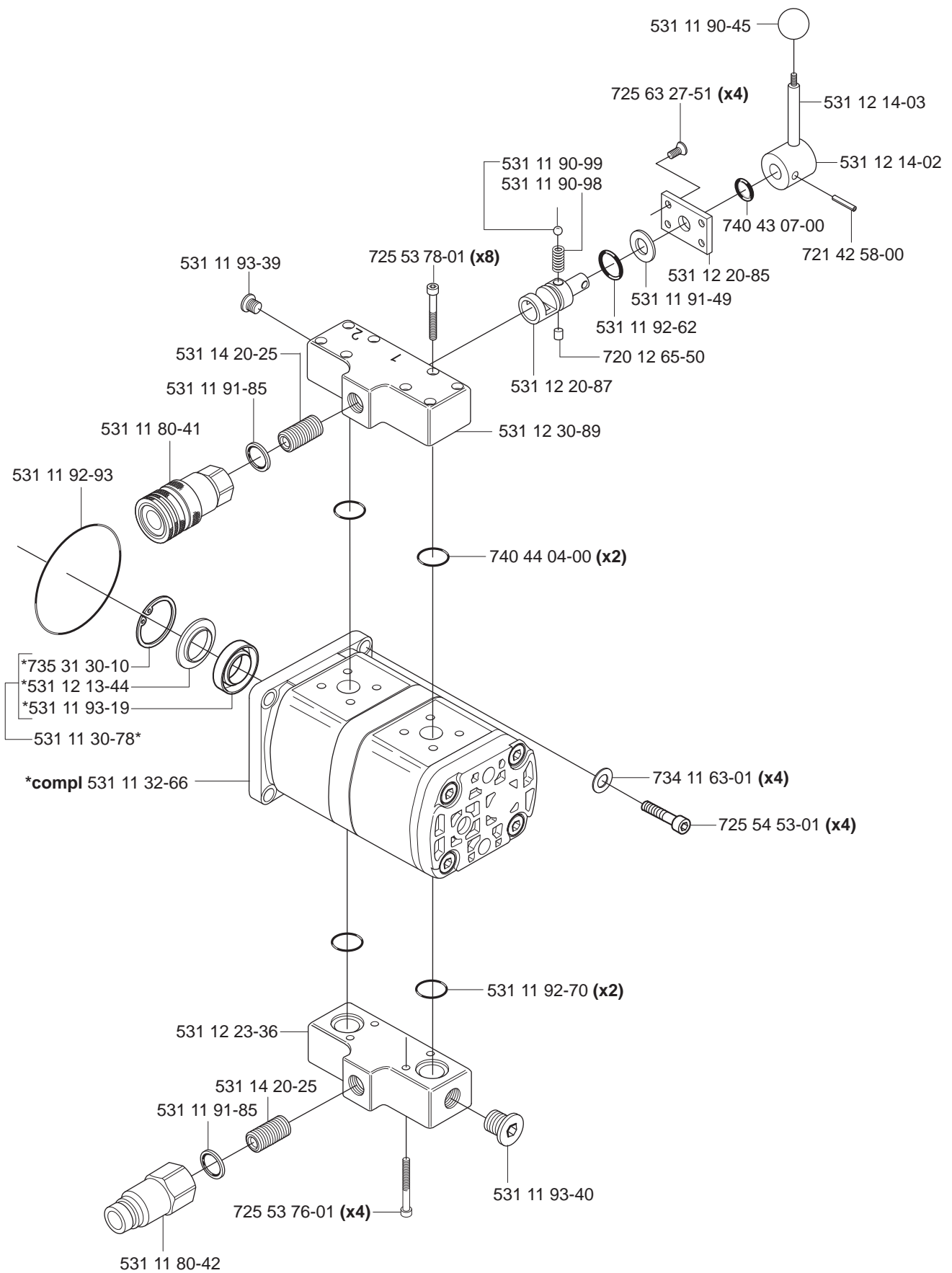



WS 462

Saw carriage 400 complete 505 22 69-01

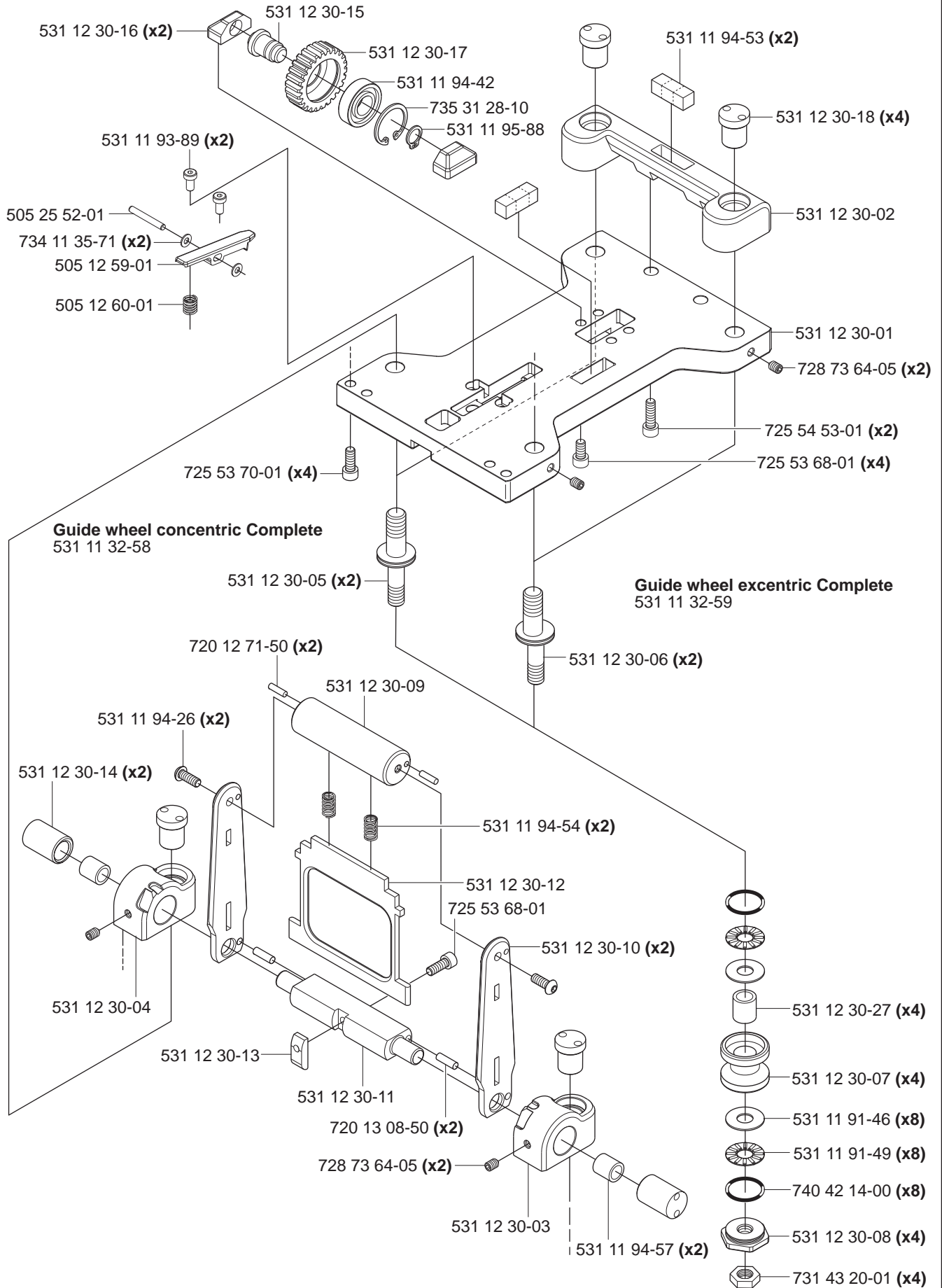

H

WS 462

Track complete

1.2m 531 11 30-45

2.0m 531 11 30-46

2.2m 531 11 30-47

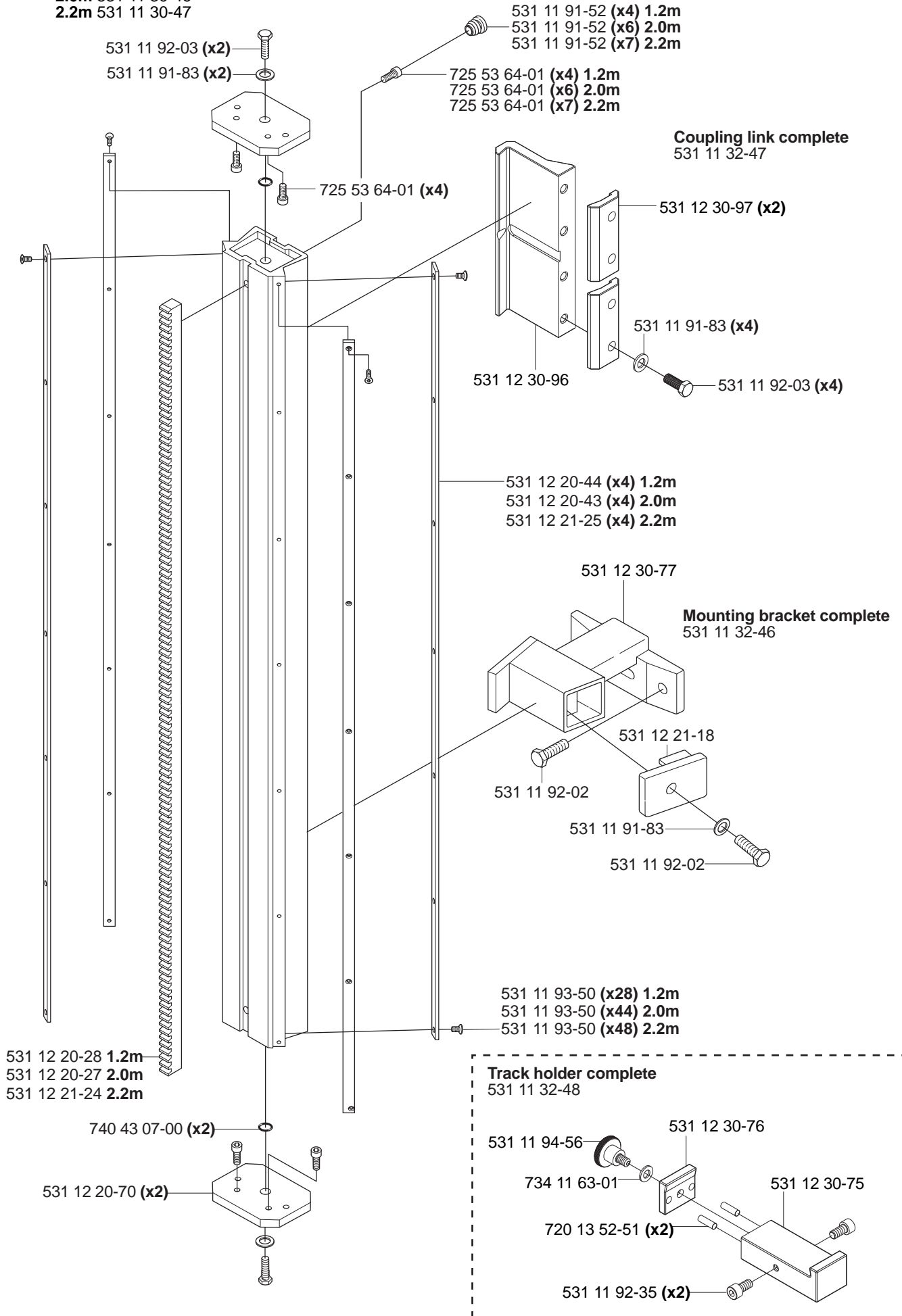

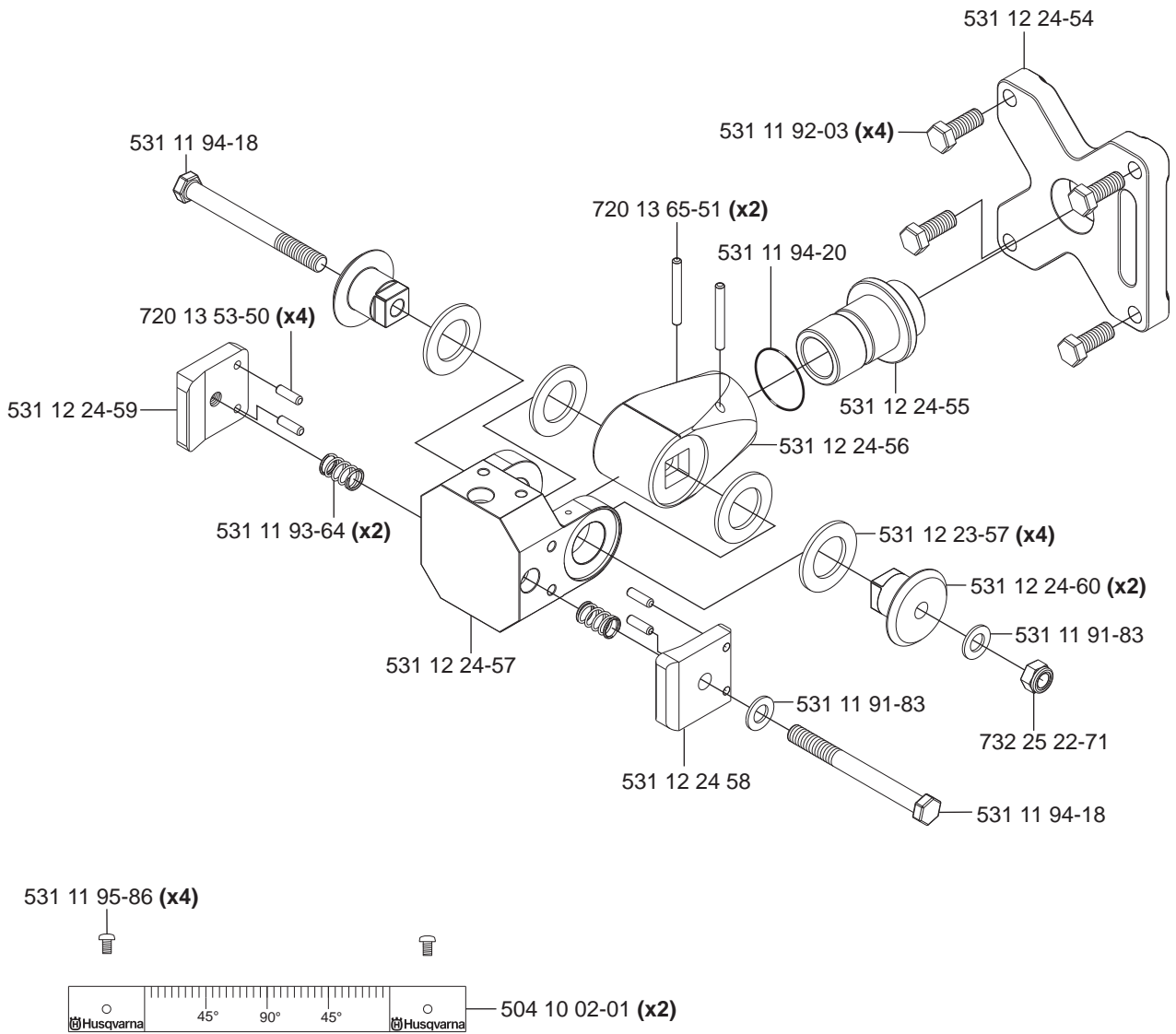
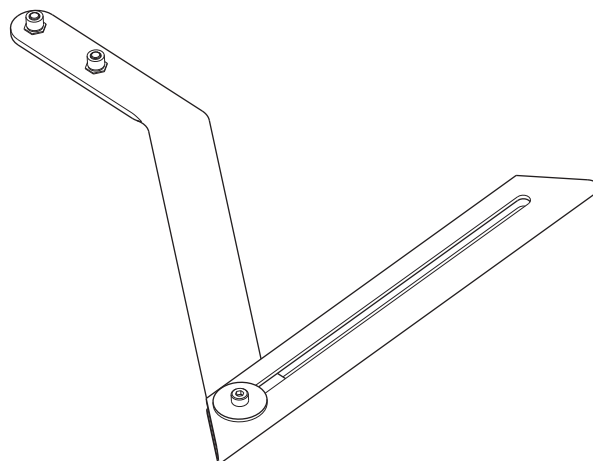
J**WS 462****Mounting bracket Universal
compl. 531 11 32-00****Measure rod complete 531 11 32-65**

K

WS 462

Blade guard guide Complete 505 18 74-01

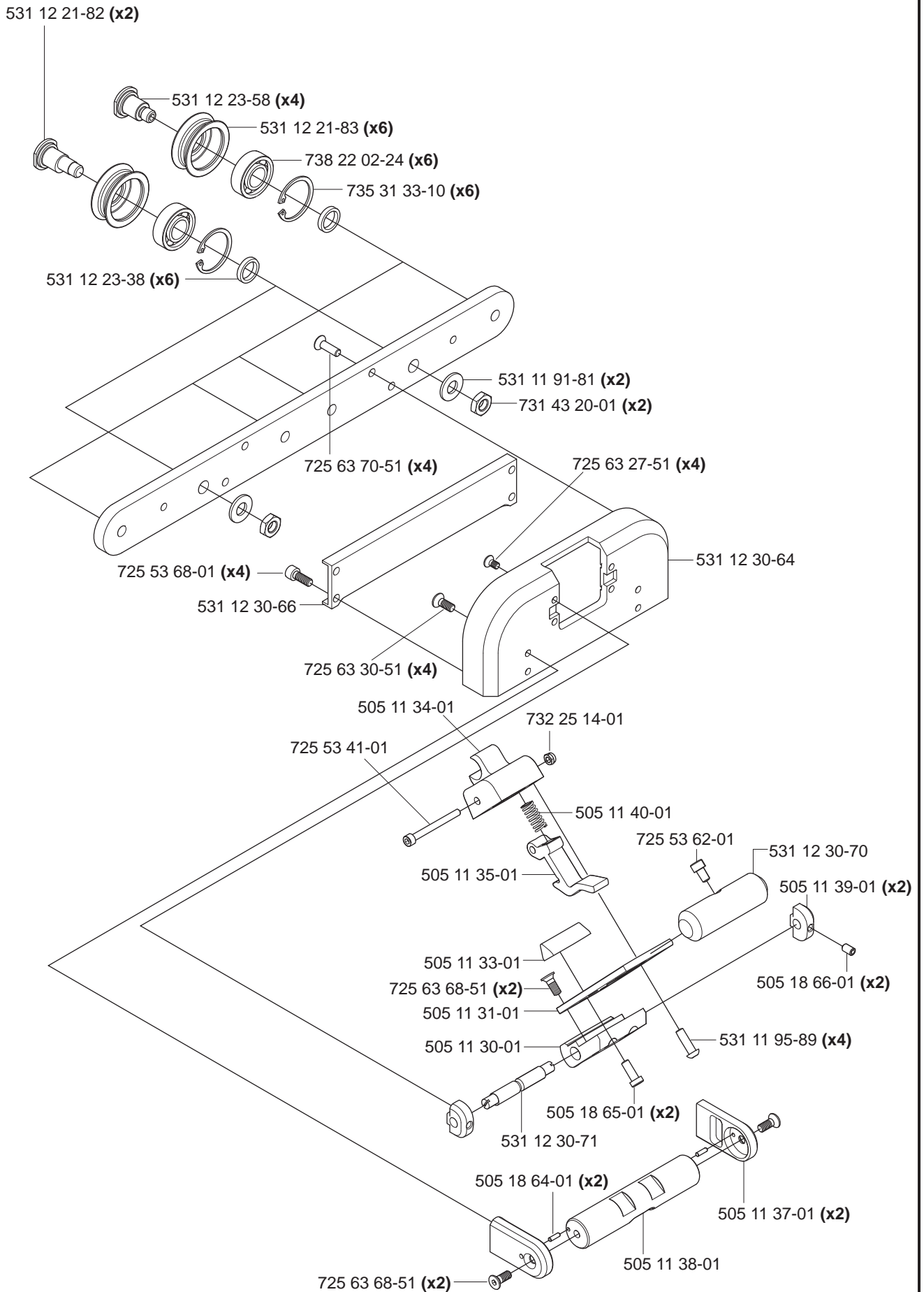



WS 462

Blade guard Complete

800mm 505 15 29-01

1000mm 505 15 30-01

1240mm 505 15 31-01

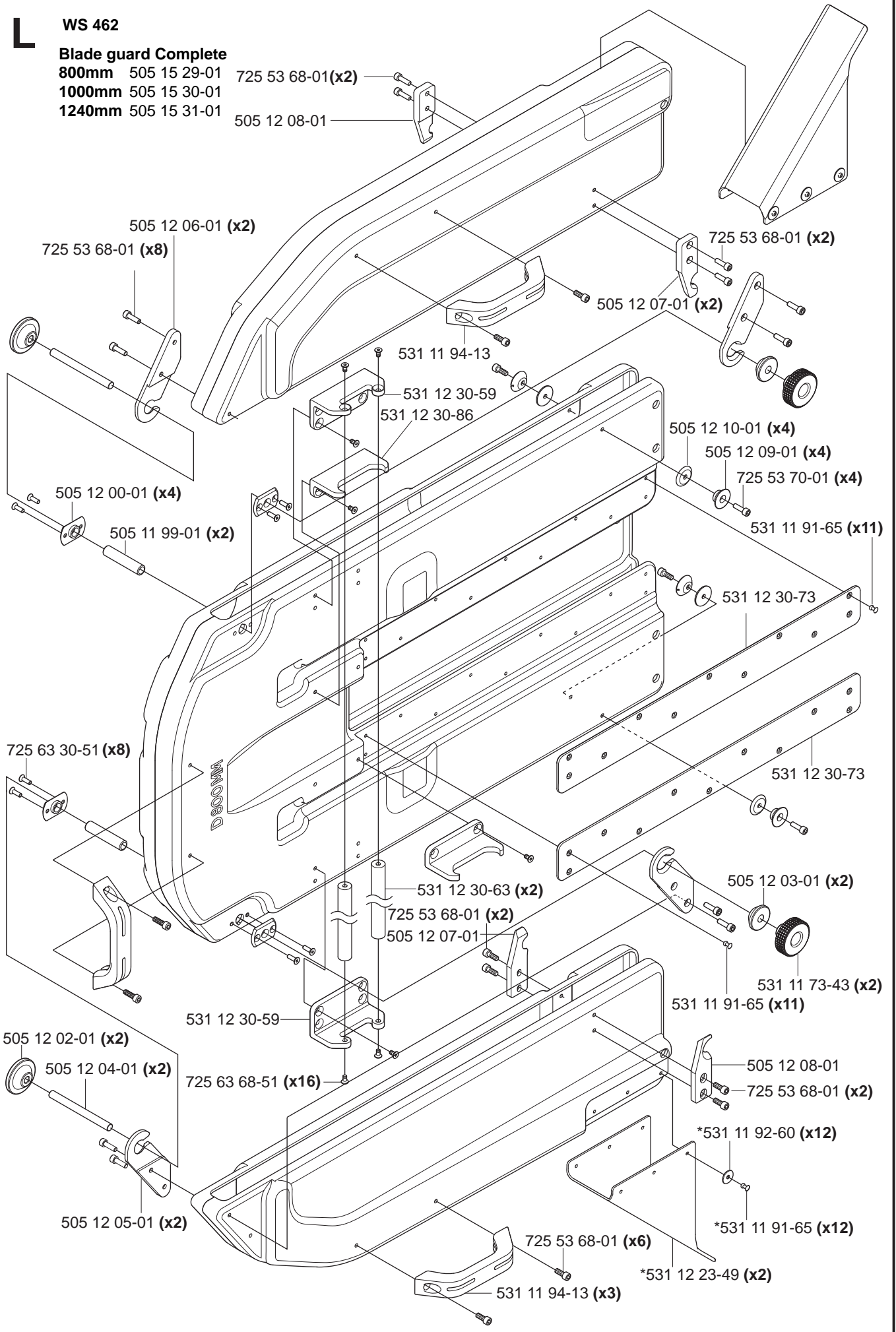

*531 12 23-45 **Splash guard compl.**

M**WS 462****Flush blade guard compl.****800mm** 504 00 50-01**1000mm** 504 00 52-01**1240mm** 504 00 53-01**Outer side, right compl.****800mm** 501 37 29-01**1000mm** 501 37 31-01**1240mm** 501 37 33-01**Edge list 3,3 Meter**

531 11 95-26

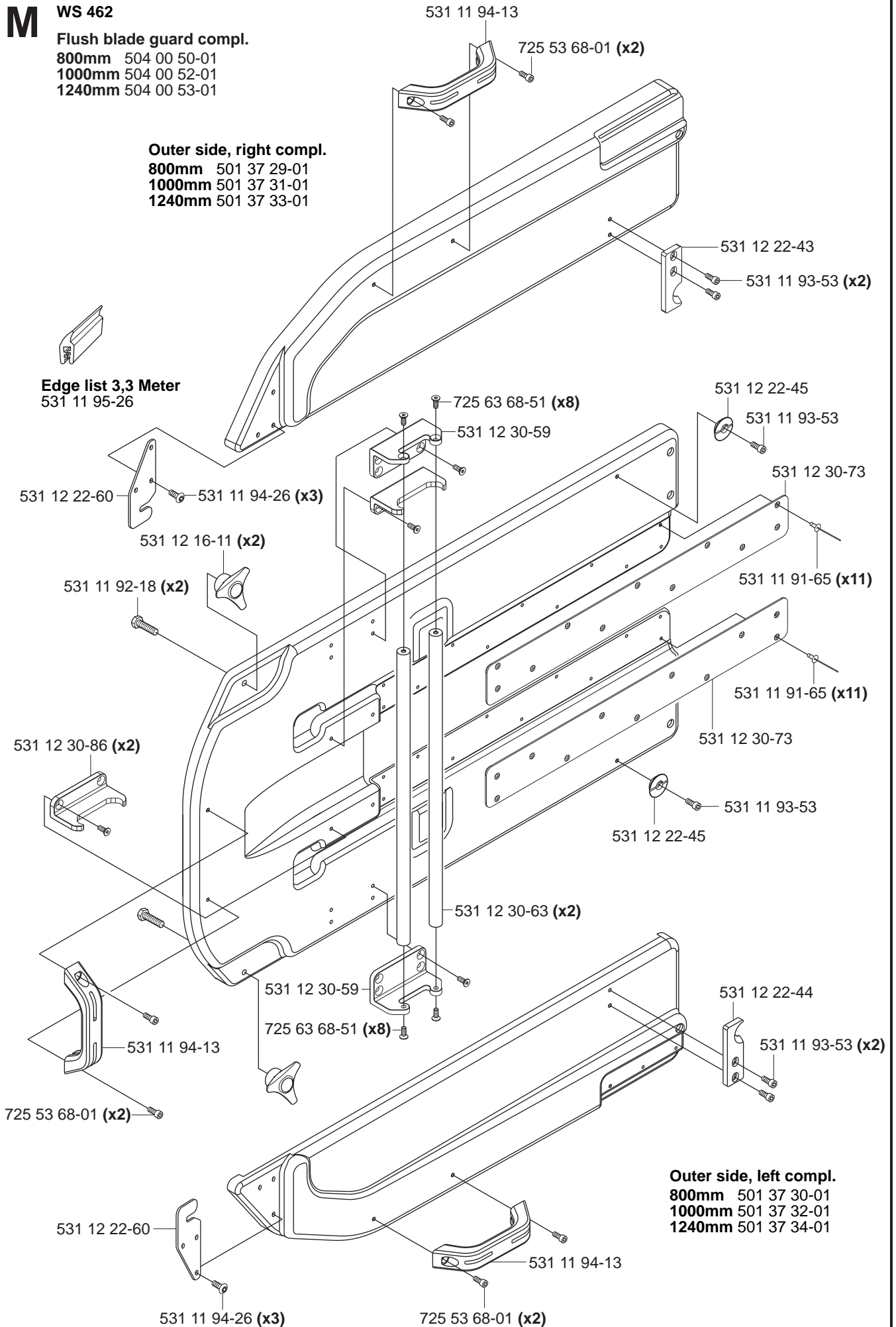

N

WS 462

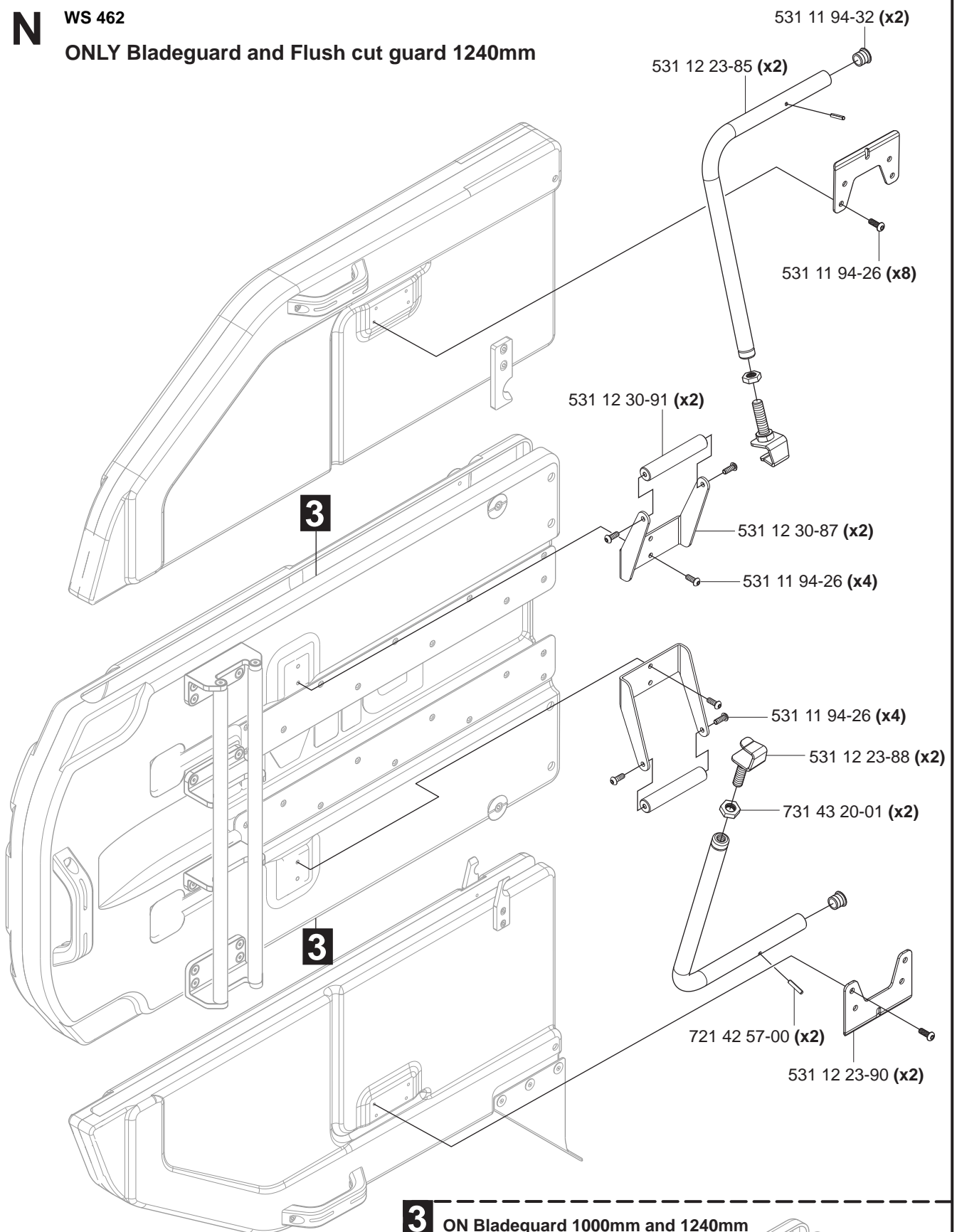
ONLY Bladeguard and Flush cut guard 1240mm**3****ON Bladeguard 1000mm and 1240mm**

732 25 16-01 (x2)

531 11 93-26 (x2)

531 12 21-68 (x2)

725 63 70-51 (x2)

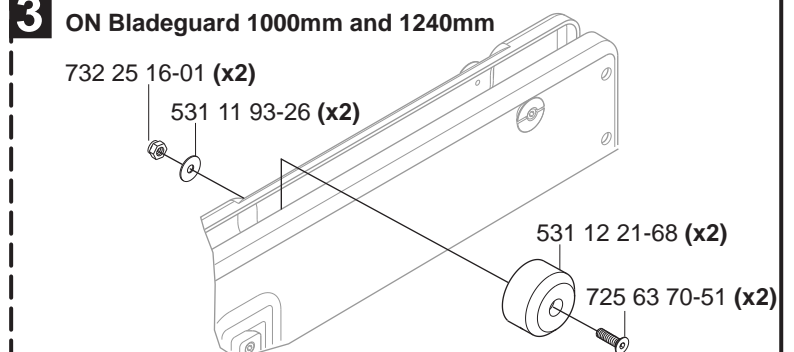

P

WS 462

Toolkit compl 501 37 52-01

504 10 29-01

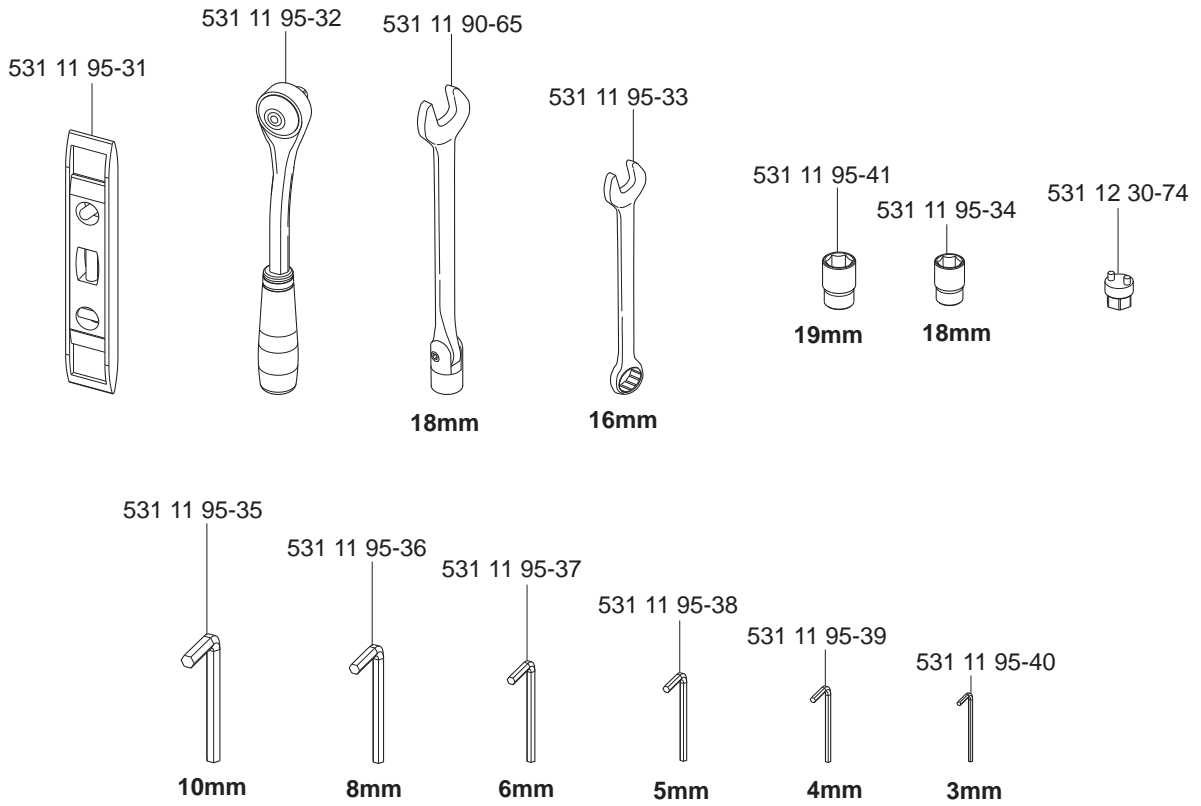
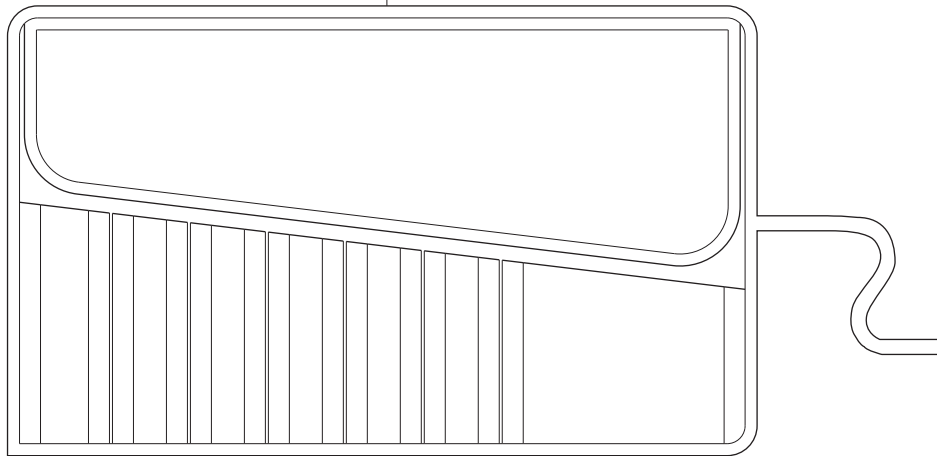

504 05 86-01



531 11 91-08



Q

WS 462

Water hose with valve complete 531 11 30-37

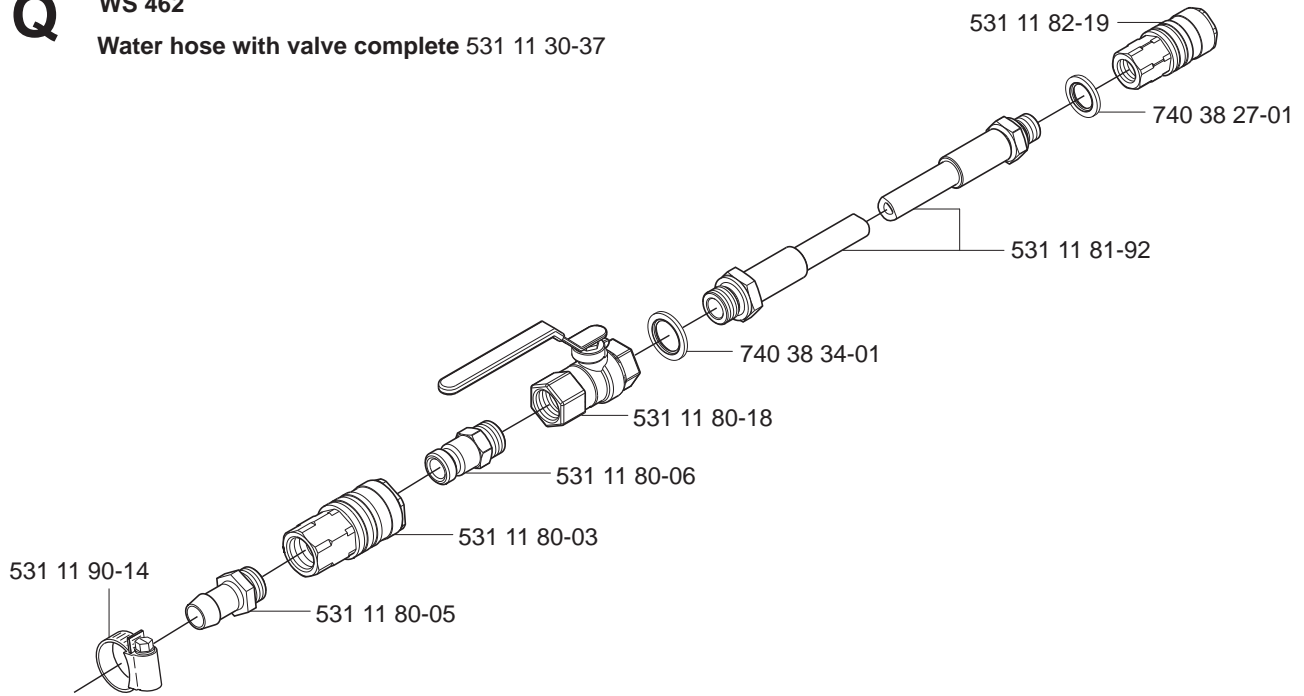

WS 463 Wear hose, water complete 531 11 33-43

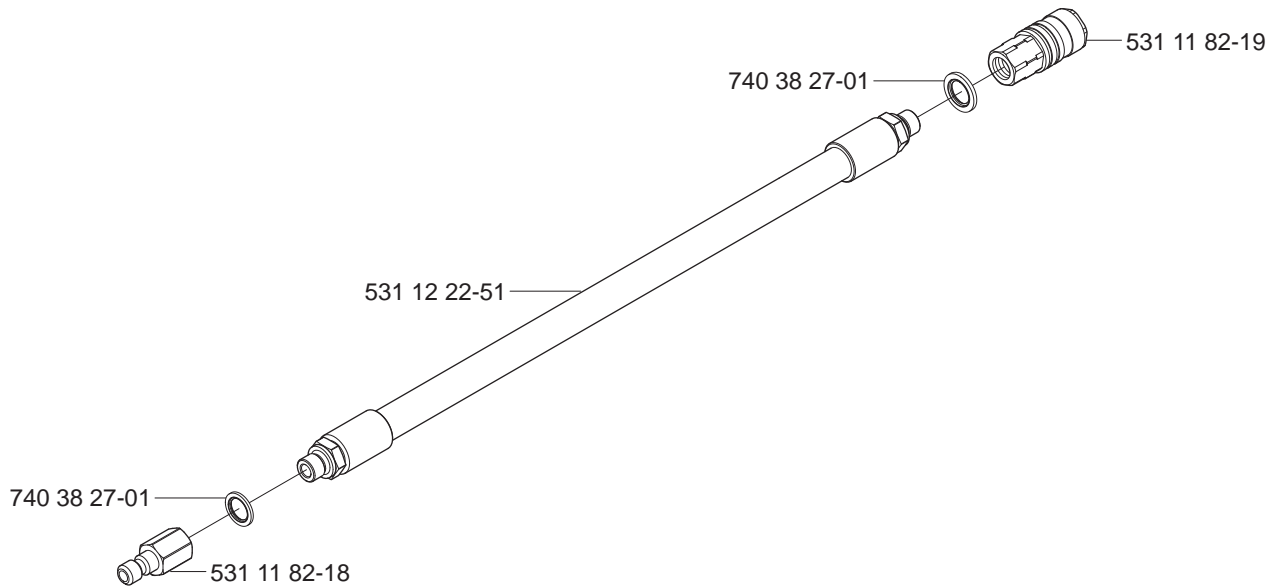

Cleanig brush complete 531 11 32-68

