 Operator's manual

Read these instructions carefully and make sure you understand them before using the machine.

TS 355 B

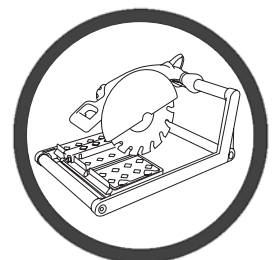



TABLE OF CONTENTS & INTRODUCTION

Table of Contents

| Section | Page No. |
|---|----------|
| Table of Contents..... | 2 |
| Introduction..... | 2 |
| Symbols & Decals | 3 - 7 |
| Safety Instructions..... | 8 - 11 |
| What-Is-What (Part Identification)..... | 12 |
| Assembly..... | 13 |
| Operation..... | 14 - 19 |
| Maintenance..... | 20 - 24 |
| Specifications..... | 25 |
| Contact Information..... | 26 |

Introduction

Thank you for purchasing your new machine from Husqvarna Construction Products. We have provided important safety messages in this manual and on the machine.

Please read these messages carefully. A safety message alerts you to potential hazards that could hurt you or others. Each safety message is preceded by a symbol or the safety alert symbol () and one of two words, **WARNING**, or **CAUTION**.

These signal words mean:

WARNING: Indicates a hazardous situation which, if not avoided **COULD** result in death or serious injury.



CAUTION: Indicates a hazardous situation, which, if not avoided, **COULD** result in minor or moderate injury. It may also be used to alert against unsafe practices.

Each message tells you what the hazard is, what can happen, and what you can do to avoid or reduce injury. Other important messages are preceded by the word **NOTICE**.

NOTICE means:

NOTICE: Indicates a hazardous situation which, if not avoided, could result in property damage. Your machine or other property can be damaged if you don't follow this instruction.

The safety labels should be periodically inspected and cleaned by the user to maintain good legibility at a safe viewing distance. If the label is worn, damaged, or is illegible, it should be replaced.

| | |
|--|---|
|  WARNING! | |
|   | <p>Before starting up machine make sure you completely read these instructions. Be familiar with operation of the machine before operation!</p> |



EVERY MACHINE IS THOROUGHLY TESTED BEFORE LEAVING THE FACTORY. EACH MACHINE IS SUPPLIED WITH A COPY OF THIS MANUAL. OPERATORS OF THIS EQUIPMENT MUST READ AND BE FAMILIAR WITH THE SAFETY WARNINGS. FAILURE TO OBEY WARNINGS MAY RESULT IN INJURY OR DEATH. FOLLOW INSTRUCTIONS STRICTLY TO ENSURE LONG SERVICE IN NORMAL OPERATION.

SYMBOLS and DECALS



- Please read the instructions for use prior to operating the machine for the first time.
- Antes de la puesta en marcha, lea detenidamente las instrucciones y familiarícese con la máquina.



- Mandatory
- Obligatorio



- Indication
- Indicación



- Prohibition
- Prohibición



- Warning Triangle
- Triángulo De Advertencia



- Wear Eye Protection
- Usar Gafas De Protección



- Wear Head Protection
- Usar Casco De Protección



- Wear Breathing Protection
- Usar Máscara De Protección



- The Use Of Ear Protection Is Mandatory
- Es Obligatorio El Uso De Protección Auditiva



- Wear a Hard Hat
- Usar Casco Duro



- Wear Safety Shoes
- Usar Zapatos De Seguridad



- Wear Appropriate Clothing
- Usar Ropa Adecuada



- Remove The Blade Prior To Hoisting, Loading, Unloading And Transporting The Machine On Jobsite.
- Desmontar El Disco Antes De Desplazar, Cargar, Descargar O Transportar La Máquina En La Obra.

SYMBOLS and DECALS



- Motor Off
- Parar El Motor



- Use In Well Ventilated Area
- Usar En Una Área Bien Ventilada



- Do Not Use In Flammable Areas
- No Usar In Áreas Inflamables



- Machinery Hazard, Keep Hands And Feet Clear.
- Máquina Peligrosa - Mantenga Manos Y Pies Alejados De La Máquina



- Danger, Poison Exhaust Gas
- Peligro, Gases De Escape Tóxicos



- No Non-working Personnel In Area
- Prohibido Para Personas Ajenas A La Obra



- No Smoking
- No Fumar



- Do Not Operate Without All Guards In Place
- No Operar Sin Todas Las Protecciones In Su Sitio



- Always Keep the Blade Guards In Place
- Mantenga Siempre Las Protecciones De La Hoja En Su Sitio



- Water Supply On
- Suministro De Agua Conectado



- Water Supply Off
- Suministro De Agua Desconectado



- Water Supply
- Suministro De Agua



- Keep Work Area Clean/Well Lit, Remove All Safety Hazards
- Mantenga Limpio El Sitio De Trabajo/Bien Iluminado, Elimine Todos Los Riesgos De Seguridad

SYMBOLS and DECALS



- Dangerously High Noise Level
- Nivel De Ruido Elevadamente Peligroso



- Pay Extreme Attention To The Care And Protection Of The Machine Before Starting Up
- Ponga Extrema Atención Al Cuidado Y Preparación De La Máquina Antes De Ponerla En Marcha



- Remove Tools From Area and Machine
- Elimine Las Herramientas Del Área Y De La Máquina



- Oil Pressure
- Presión De Aceite



- Oil Required
- Necesita Aceite



- Dipstick, Maintain Proper Oil Level
- Varilla De Control, Mantenga El Nivel De Aceite Correcto



- Lubrication Point
- Punto De Lubrication



- Unleaded Fuel Only
- Solamente Combustible Sin Plomo



- Repairs Are To Be Done By An Authorized Dealer Only
- Las Reparaciones Deben Ser Efectuadas Únicamente Por Un Distribuidor Autorizado



- Diamond Blade
- Sierra Diamantada



- Blade Diameter
- Diámetro De La Hoja

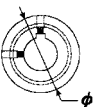

- Pulley Diameter
- Diámetro De La Correa

SYMBOLS and DECALS



- Number of Revolutions Per Minute, Rotational Speed
- N° De Revoluciones Por Minuto, Velocidad De Rotación

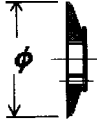

- Blade Flange Diameter
- Diámetro De La Brida De La Hoja

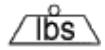

- Weight (lbs)
- Masa De La Máquina (lbs)



- Engine
- Motor



- Engine Speed Revolutions/Minute
- Velocidad Del Motor En Revoluciones Por Minuto (RPM)



- Engine Start
- Arranque Del Motor



- Electric Motor
- Motor Electrica

SYMBOLS and DECALS



TARGET GUARDMATIC TS 355 B

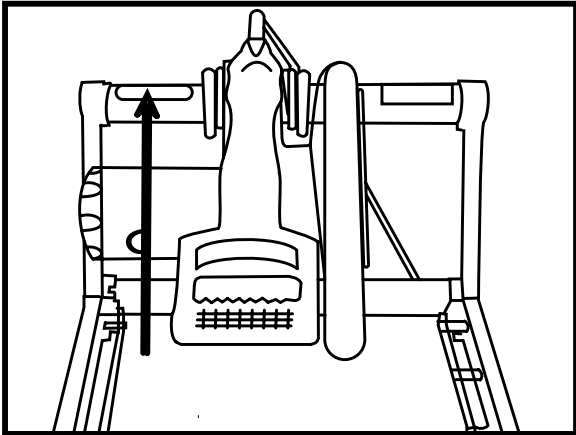

Caution Safety Label
P/N 155576

Location: Left Side, Upper Cross Member

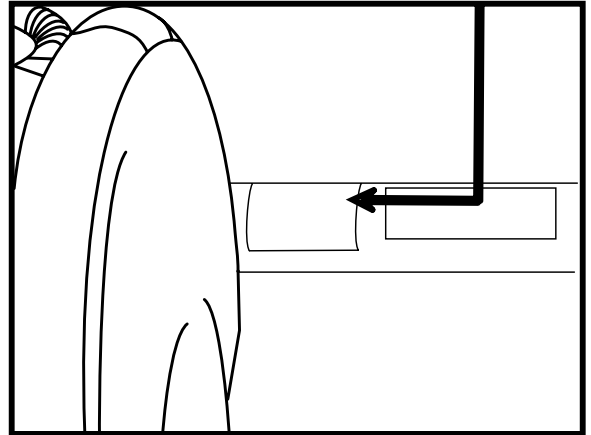

Dust Inhalation Warning Label
P/N 154337

Location: Right Side, Upper Cross Member

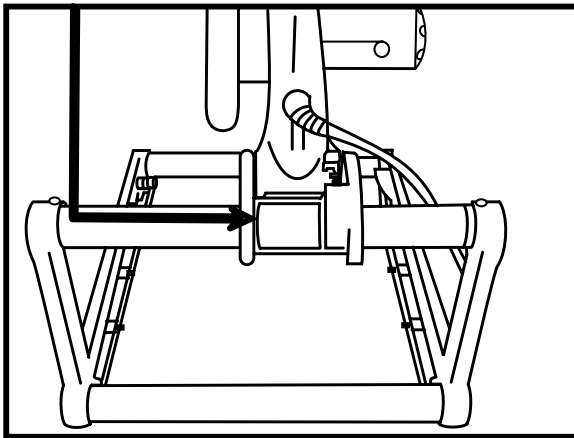

Extension Cord Warning Label
P/N 155672

Location: Back, Upper Cross Member

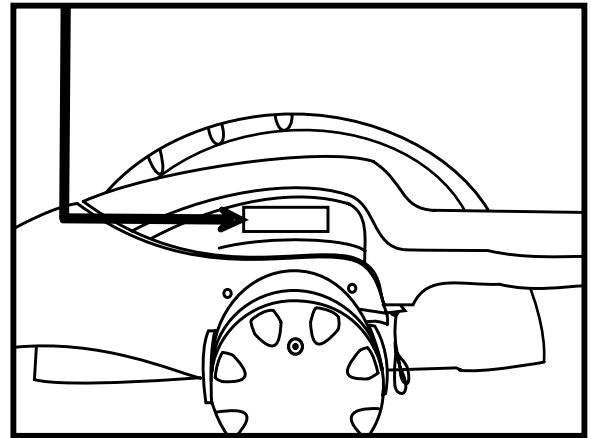

Serial Number and Motor Specifications
P/N 158096

Location: Blade Guard

SAFETY INSTRUCTIONS

| WARNING! | |
|-----------------|--|
| | Before starting up machine make sure you completely read these instructions. Be familiar with operation of the machine before operation! |
| | |

| | | | |
|--|------------------|--|---|
| | MANDATORY | | INDICATION INFORMATION INSTRUCTION |
|--|------------------|--|---|

| | | | |
|--|----------------|--|--------------------|
| | WARNING | | PROHIBITION |
|--|----------------|--|--------------------|

These signs will give advice for your safety

Before leaving our factory every machine is thoroughly inspected.

Follow our instructions strictly and your machine will give you long service in normal operating conditions.

| WARNING! | |
|---|--|
| Always make sure the saw is connected to a properly grounded electrical outlet. Failure to comply with this warning could result in serious bodily injury or death! | |



The operator must wear protective clothing appropriate to the work he is doing.



Any persons not involved in the work should leave the area.

| | |
|--|---|
| | The working area must be completely clear, well lit and all safety hazards removed. |
|--|---|

| | |
|--|--|
| | Any persons not involved in the work, should leave the area. |
|--|--|

| WARNING! | |
|--|--|
| Use ONLY Reinforced Abrasive Blades or Diamond Blades with this machine. | |
| Use ONLY blades marked with a maximum operating speed greater than the blade shaft speed. | |
| DO NOT use carbide tipped, wood cutting, or circular saw blades with this machine. | |
| Before performing any maintenance, ALWAYS locate the machine on a level surface with the engine / motor OFF and the start switch in the OFF position, and the power source disconnected. | |

SAFETY INSTRUCTIONS

WARNING!

HEARING HAZARD! DURING NORMAL USE OF THIS MACHINE, OPERATOR MAY BE EXPOSED TO A NOISE LEVEL EQUAL OR SUPERIOR TO **85 dB (A)**

DUST WARNING

Cutting, especially when DRY cutting, generates dust that comes from the material being cut, which frequently contains silica. Silica is a basic component of sand, quartz, brick clay, granite and numerous other minerals and rocks. Exposure to excessive amount of such dust can cause:

- Respiratory diseases (affecting your ability to breath), including chronic bronchitis, silicosis and pulmonary fibrosis from exposure to silica. These diseases may be fatal;
- Skin irritation and rash; and
- Cancer according to NTP* and IARC*
* National Toxicology Program, International Agency for Research on Cancer

Take precautionary steps

- Avoid inhalation of and skin contact with dust, mist and fumes;
- Wet cut when feasible, to minimize dust;
- Wear and ensure that all bystanders wear appropriate respiratory protection such as dust masks designed to filter out microscopic particles. (See OSHA 29 CFR Part 1910.1200)

California Prop 65 Warning:

Use of this product can cause exposure to materials known to the State of California to cause cancer and/or birth defects or other reproductive harm.

SAFETY FIRST!



WARNINGS DO's AND DO NOT's



WARNING: FAILURE TO COMPLY WITH THESE WARNINGS AND OPERATING INSTRUCTIONS COULD RESULT IN DEATH OR SERIOUS BODILY INJURY.

DO

- DO read this entire operator's manual before operating this machine. Understand all warnings, instructions, and controls.
- DO keep all guards in place and in good condition.
- DO wear safety approved hearing, eye, head and respiratory protection.
- DO read and understand all warnings and instructions on the machine.
- DO read and understand the symbol definitions contained in this manual.
- DO keep all parts of your body away from the blade and all other moving parts.
- DO know how to stop the machine quickly in case of emergency.
- DO shut off the engine and allow it to cool before refueling.
- DO inspect the blade, flanges and shafts for damage before installing the blade.
- DO use only reinforced abrasive blades or steel center diamond blades manufactured for use on masonry saws.
- DO use only blades marked with a maximum operating speed greater than the blade shaft speed. Verify speed by checking blade shaft rpm and pulley diameters and blade flange diameters.
- DO verify saw drive configuration by checking blade shaft RPM, pulley diameters, and blade flange diameter.
- DO read all safety materials and instructions that accompany any blade used with this machine.
- DO inspect each blade carefully before using it. If there are any signs of damage or unusual wear, **DO NOT USE THE BLADE.**
- DO mount the blade solidly and firmly. Wrench tighten the arbor nut.
- DO verify the blade arbor hole matches the machine spindle before mounting the blade.
- DO make sure the blade and flanges are clean and free of dirt and debris before mounting the blade on the saw.
- DO use dry cutting diamond blades with a 1" (diameter arbor only). Never use damaged or worn blade flanges.
- DO use the correct blade for the type of work being done. Check with blade manufacturer if you do not know if blade is correct.
- DO operate this machine only in well ventilated areas.
- DO instruct bystanders, visitors and children to stand a safe distance from work area.
- DO establish a training program for all operators of this machine.
- DO clear the work area of unnecessary people. Never allow anyone to stand in front of or behind the blade while the engine is running.
- DO make sure the blade is not contacting anything before starting the engine.
- DO reduce the risk of unintentional starting. Make sure the trigger switch/locking button is in the **RELEASE** position before plugging in a power tool.
- DO tie down the machine when transporting. Use caution and follow instructions for transporting the machine.
- DO have all service performed by competent service personnel.
- DO use caution when handling fuel. Make sure the gas caps of the machine and the fuel can are properly tightened before starting the engine. Move fuel can at least 10 feet from machine after fueling.
- DO remove adjusting keys and wrenches from tool before turning it on.
- DO make the workshop kid-proof by using padlocks, master switches or by removing starter keys.
- DO keep the handles dry, clean and free of oil and dirt. Clean the machine after each day's use.
- DO carefully maintain and clean for better and safer performance. Follow instructions for changing accessories. Inspect tool cords periodically and, if damaged, have repaired by authorized service facility.
- DO use the proper blade flange size for each blade size. Never use damaged or worn blade flanges.
- DO only cut in a straight line. Always feed work into a blade or cutter against the direction of rotation.
- DO **make sure electric powered machines are plugged into a properly grounded circuit.**
- DO **make sure power cords are the proper size and in good condition.**
- DO **follow all electrical codes in your area.**
- DO **use correct voltage and proper extension cords. Never carry tool by cord or yank it to disconnect it from receptacle. Keep cord away from heat, oil and sharp edges.**
- DO **disconnect tools from power source when not in use, before servicing and when changing accessories.**
- DO **carefully maintain and clean for better and safer performance. Follow instructions for changing accessories. Inspect tool cards periodically and, if damaged, have repaired by authorized service facility.**
- DO always give a copy of this manual to the equipment user. For extra copies, call TOLL FREE 1-800-288-5040.

SAFETY FIRST!



WARNING: FAILURE TO COMPLY WITH THESE WARNINGS AND OPERATING INSTRUCTIONS COULD RESULT IN DEATH OR SERIOUS BODILY INJURY.

DO NOT

- DO NOT** operate this machine unless you have read and understood this operator's manual.
- DO NOT** operate this machine without the blade guard, or other protective guards in place.
- DO NOT** leave this machine unattended while the engine is running.
- DO NOT** work on this machine while the engine is running.
- DO NOT** operate this machine when you are tired or fatigued.
- DO NOT** use a wet blade without adequate water supply to the blade.
- DO NOT** exceed maximum blade speed shown for each blade size. Excessive speed could result in blade breakage.
- DO NOT** operate the machine if you are uncertain of how to run the machine.
- DO NOT** use damaged equipment or blades.
- DO NOT** stand on the tool. Injury may occur if a power tool is tipped or a cutting tool is unintentionally contacted.
- DO NOT** overreach. Keep proper footing and balance at all times by not overreaching.
- DO NOT** touch or try to stop a moving blade with your hand.
- DO NOT** cock, jam, wedge or twist the blade in a cut.
- DO NOT** transport a cutting machine with the blade mounted on the machine.
- DO NOT** use a blade that has been dropped or damaged.
- DO NOT** use carbide tipped blades.
- DO NOT** lay power cords in or near water.
- DO NOT** touch electrical wires or components while the motor is running.
- DO NOT** replace the motor with any motor that does not have a special grounding connection.
- DO NOT** use segmented diamond blades without water unless specifically designed for dry cutting.
- DO NOT** touch a dry cutting diamond blade immediately after use. These blades require several minutes to cool after each cut.
- DO NOT** use damaged or worn blade flanges.
- DO NOT** allow other persons to be near the machine when starting, refueling, or when the machine is in operation.
- DO NOT** operate this machine in an enclosed area unless it is properly vented.
- DO NOT** operate this machine in the vicinity of anything that is flammable. Sparks could cause a fire or an explosion.
- DO NOT** allow blade exposure from the guard to be more than 180 degrees.
- DO NOT** operate this machine with the belt guard or blade guard removed.
- DO NOT** operate this machine unless you are specifically trained to do so.
- DO NOT** use a blade that has been over heated.
- DO NOT** jam material into the blade.
- DO NOT** grind on the side of the blade.
- DO NOT** start cutting with a saw until you have a clear work area and secure footing.
- DO NOT** operate this machine while under the influence of drugs or alcohol.
- DO NOT** use improper accessories that may increase the risk of personal or bystander injury. Consult the owner's manual for recommended accessories.

This saw was designed for certain applications only. DO NOT modify this saw or use for any application other than for which it was designed. If you have any questions relative to its application, DO NOT use the saw until you have written Diamant Boart, Inc. and we have advised you.

Husqvarna Construction Products, North America
17400 West 119th Street
Olathe, Kansas 66061
In USA 1-800-288-5040

WHAT-IS-WHAT (PARTS IDENTIFICATION)

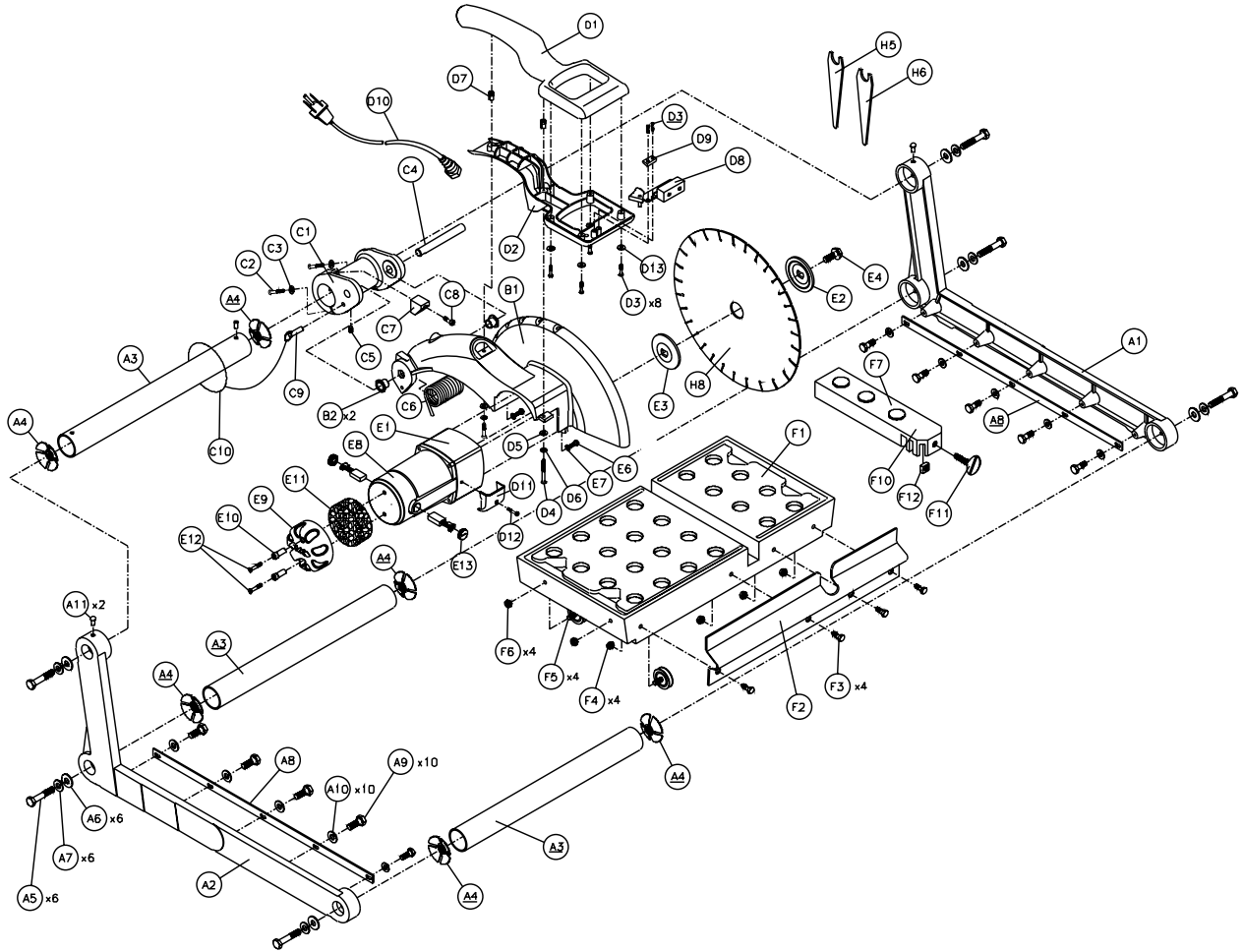

| | | | |
|-----|--|------|--|
| A1 | Casting, Frame, Right | D10 | Cord, AC Power 120V |
| A2 | Casting, Frame, Left | D11 | Cover, Wire |
| A3 | Support, Horizontal Frame | D12 | Screw, # 6-32 x 1 1/4, Socket Flat Head |
| A4 | Tube Connector, 1/4-20 | D13 | Washer, #6 Flat SAE |
| A5 | Screw, 1/4-20 x 1 1/2 Hex Head Cap | E1 | Motor, AC 115 Volt / 13 Amp, 3500 RPM |
| A6 | Washer, 1/4 SAE Flat | E2 | Flange, Outer |
| A7 | Washer, 1/4 Split Lock | E3 | Flange, Inner |
| A8 | Strap, Table Guide Rail | E4 | Screw, M10 – 1.5 x 20mm Hex Flange |
| A9 | Screw, 1/4-20 x 3/4, Hex Head Ca | E6 | Screw, M6-1 x 20mm Hex Head Cap |
| A10 | Washer, 1/4 Split Lock | E7 | Washer, M6 Split Lock |
| A11 | Drive Stud, Round Head Grooved #16 (1/4) x 1/2 | E8 | Cap, Motor |
| B1 | Casting, Arm, Motor Mount | E9 | Cap, Motor Filter |
| B2 | Bushing, Nylon Flange | E10 | Spacer Pin, Cap Screw |
| C1 | Casting, Pivot Clamp | E11 | Filter Element |
| C2 | Screw, 1/4-20 x 1 1/4 Socket Hd. Cap | E12 | Screw, #6 x 1 1/2, Combo Head Pan, Tapping |
| C3 | Washer, 1/4 Split Lock | E13 | Motor Brush Cap |
| C4 | Pin, Pivot, .625 x 5.6 | F1 | Casting, Table |
| C5 | Screw, Set 1/4-20 x 1/4 Cup Point | F2 | Stop, Rule |
| C6 | Spring, Torsion | F3 | Screw, 1/4-20 x 3/4 Hex Head Cap |
| C7 | Stop Block | F4 | Nut, 1/4-20, Hex w/ External Tooth Washer |
| C8 | Screw, 1/4-20 x 5/8, Socket Hd Cap | F5 | Wheel, Roller |
| C9 | Pin, Detent w/ Pull Ring | F6 | Nut, 5/16-18, Hex w/ External Tooth Washer |
| C10 | Lanyard | F7 | Wood Strip, Table Insert |
| D1 | Handle, Upper | F10 | Casting, Squaring Arm |
| D2 | Handle, Lower | F11 | Screw, 5/16-18 x 1 1/2, Thumb |
| D3 | Screw, M3.5 x 12mm | F12 | Nut, 5/16-18 Square |
| D4 | Screw, 1/4-20 x 3/4, Socket Hd. Cap | H5 | Wrench, Blade Nut |
| D5 | Washer, 1/4 SAE, Flat | H6 | Wrench, Shaft |
| D6 | Washer, 1/4 Split Lock | H7 | Extra Filter Element (Accessory Pack) |
| D7 | Insert, Expansion, 1/4-20 Standard | H8 | Blade, Dry Cutting 14", Segmented |
| D8 | Switch, Trigger | H8-A | Blade, Dry Cutting 14", Segmented Block (Accessory Pack) |
| D9 | Plate, Screw, Switch Mounting | | Owner's Manual (Accessory Pack) |

ASSEMBLY

Diamond Blade Installation



NOTICE

When installing the Retaining Screw (E4), do not “cross-thread” or over tighten the screw.

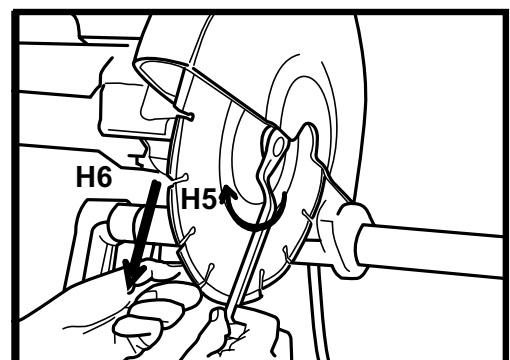
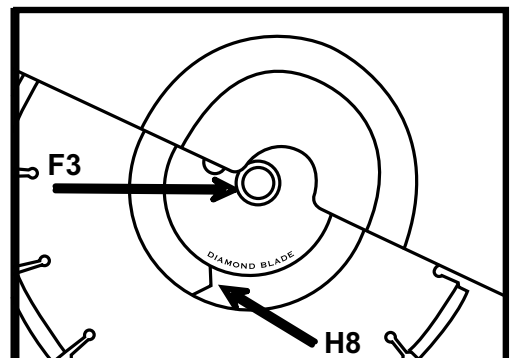
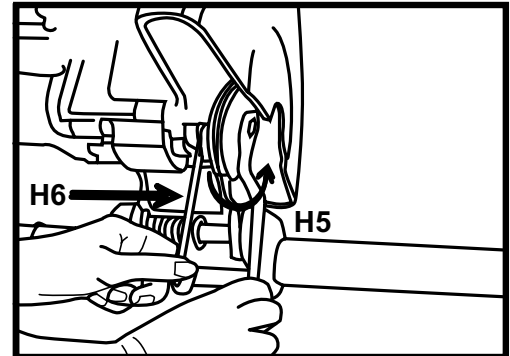
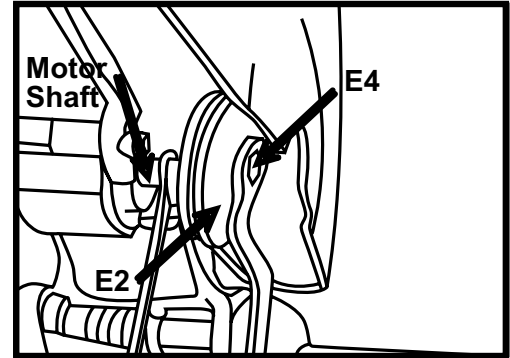
- Identify Motor Shaft, Retaining Screw (E4) and Outer Flange (E2).
- Hold Shaft Wrench (H6) stationary. Rotate Blade Wrench (H5) counter-clockwise. Remove Retaining Screw and Outer Flange.
- Seat Blade (H8) on Inner Flange (F3). Verify rotation direction.
- Hold Shaft Wrench (H6) stationary. Rotate Blade Wrench (H5) clockwise. Install Retaining Screw (E4) and Outer Flange (E2). Tighten.



OPERATION

|  WARNING! | |
|---|--|
|  | Before starting up machine make sure you completely read these instructions. Be familiar with operation of the machine before operation! |



Use: Wet or Dry sawing of masonry and refractory materials such as brick and block, as shown in American National Standard Institute, B7.1-2000 "SAFETY REQUIREMENTS FOR THE USE, CARE & PROTECTION OF ABRASIVE WHEELS" (ANSI B7.1-2000). This machine is designed for use as a Masonry Saw, and conforms to ANSI B7.1-2000. All other applications are prohibited. Not for use with material shapes that are unstable on a flat surface, such as rocks, natural stone, or man-made material of irregular shape.

Tools: Diamond blades — dry or water cooled.
Reinforced Abrasive blades — dry cutting only.

Sizes:

Ø: 12" (300 mm), 14" (356 mm), 18" (450 mm), and 20" (500 mm) with Arbor Ø 1" (25.4 mm).

For information contact your Dealer, and obtain a copy of ANSI B7.1-2000.

|  WARNING! | |
|---|--|
| Use ONLY REINFORCED Abrasive Blades or Diamond Blades with this machine. | |
| Use ONLY blades marked with a maximum operating speed greater than the blade shaft speed. | |
| DO NOT use carbide tipped, wood cutting, or circular saw blades with this machine. | |
| Conventional "Wet" diamond blades MUST be used with water. | |
| DO NOT use Abrasive Blades WITH water! | |

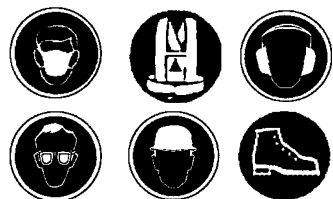

The operator must wear protective clothing appropriate to the work he is doing.

Description: The TS 355B is a versatile lightweight, dry, masonry saw. It is engineered as a 14" dry saw, consisting of a powerful 115v motor in a hard plastic case. The saw is capable of cutting brick and masonry up to 8" x 8" x 16" in size; the blade has a 5" cutting depth.

Features: Designed with a spring-assisted Cutting Head to allow for easier step cutting. The Cutting Head can be locked in a down position when cutting smaller pieces. This machine also has a lockable trigger-operating switch in the handle. For extended operating life, this machine is designed with a clean motor air filter and replaceable motor brushes.

Masonry Types: Can cut a variety of masonry types including cinder block, slump stone block, wall brick, paver brick, concrete block and cylinders, roofing tile, marble, granite, decorative rock or almost any other non-ferrous material.

| NOTICE |
|--|
| This machine is not designed to cut plastic or ferrous (metal) material. |

Depth of Cut (Maximum):

5.00" (127 mm) with Ø 14" (356 mm) blade.

Maximum Material Size:

8" x 8" x 16" (20.3 x 20.3 x 40.6 cm) block.

Nominal Weight: See "Specifications".

Operating Weight: See "Specifications".

Dimensions: See "Specifications".

Blade Guard Capacity: See "Tools" above.

OPERATION

Check Before Operation:

- Make sure that extension cord length is properly sized for motor used on saw. See chart below.

| EXTENSION CORD SIZE (A.W.G. Minimum) | | | | |
|--------------------------------------|-------|-------|-----------------|--------|
| Motor HP | 25 ft | 50 ft | 100 ft | 150 ft |
| | | 120 V | 120 V | 120 V |
| AWG | 14 | 12 | Not recommended | |

- Use only extensions cords that are intended for outdoor use and have an electrical rating not less than the rating of the product. Use only 3-wire extension cords that have 3-prong grounding plugs and 3-pole receptacles that accept the tool's plug.
- Keep all connections dry, off the ground, away from heat and sharp edges. Always disconnect the extension cord from the receptacle before disconnecting the product from the extension cord. Do not touch the plug with wet hands. Repair or replace a damaged or worn cord immediately.

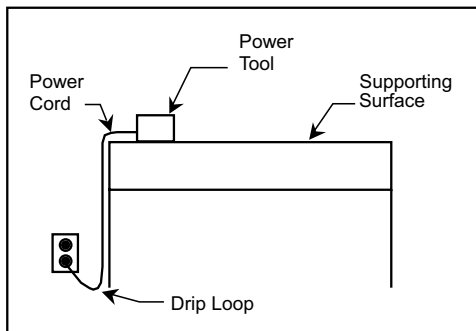

- To avoid getting the plug wet, a "drip loop" should be arranged to properly position the power cord relative to the power source, as indicated above. The "drip loop" is that part of the cord below the level of the receptacle, or the connector, if an extension cord is used. This method of positioning the cord prevents water from travelling along the power cord and coming in contact with the receptacle.
- If the plug or receptacle gets wet, DO NOT unplug the cord. Disconnect the fuse or circuit breaker that supplies power to the tool. Then unplug and examine for presence of water in the receptacle.

⚠ WARNING!

Always make sure the saw is connected to a properly grounded electrical outlet. Failure to comply with this warning could result in serious bodily injury or death!

- In case of a malfunction, grounding provides a path of least resistance for electric current to reduce the risk of electric shock.
- Do not modify the plug provided. If it will not fit, have the proper outlet installed by a qualified electrician. If repair or replacement of the electric plug is necessary, do not connect the equipment-grounding conductor to a live terminal.

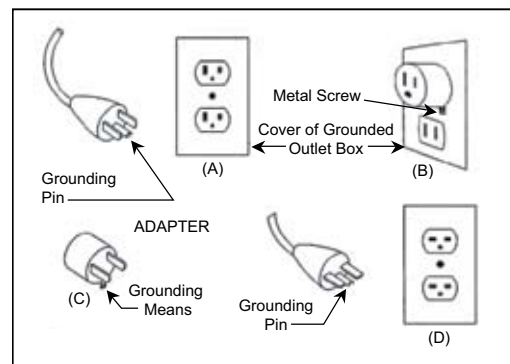

- This saw is intended for use on a circuit as shown above. The tool has a grounding plug (A). A temporary adapters (C) may be used to connect this plug to a 2-pole receptacle (B), if a properly grounded outlet is not available. The adapter should be used only until a grounded outlet can be installed by a qualified electrician.

NOTE: Use of a temporary adapter is not permitted in Canada.

NOTICE

DO NOT operate on low voltage! Low voltage causes loss of power, motor overheating, and possibly motor winding burnout. Voltage should be checked at the motor while it is operating.

Electric Motor Plugs & Connectors

| Motor | Wired For Voltage | Motor Pigtail Plug (NEMA No.) | Connector Required (NEMA No.) |
|----------|-------------------|-------------------------------|-------------------------------|
| 1-1/2 HP | 115 V | L5-20P | L5-20R |
| 2 HP | 230 V | L6-15P | L6-15R |
| 3 HP | 230 V | L6-30P | L6-30R |

OPERATION

Pre-Start Inspection

NOTICE

The pre-start inspection should be performed before beginning any job. In order to avoid breaker tripping, a 20-amp circuit breaker should be used.

- Inspect Blade (H8) for damage. Verify that the Blade is correct for the material being cut.
- Inspect other areas for damage, including the Frame Assembly (A), Motor Mount Assembly (B), Handle and Cord Assembly (D) and Table Assembly (F).
- Inspect Motor Air Filter (E11) for cleanliness.
- Verify that the Trigger Switch (D8) on the underside of the handle is unlocked.

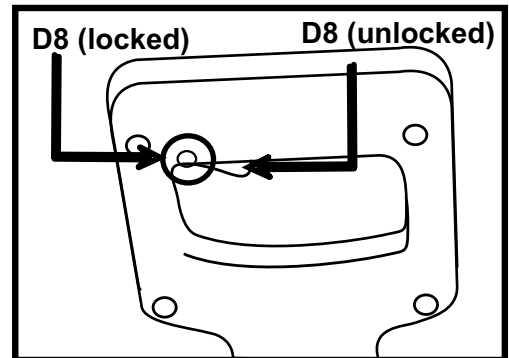
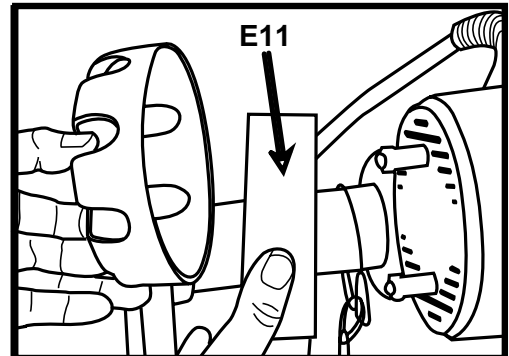
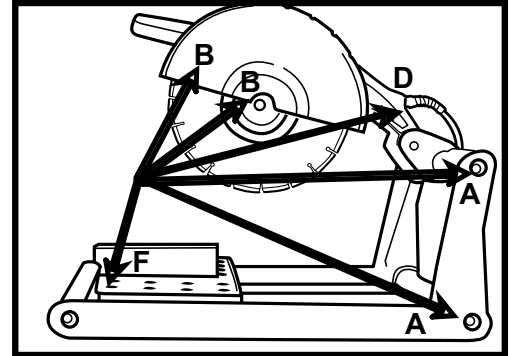
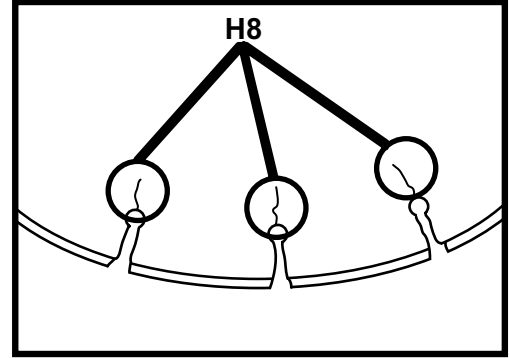

OPERATION

Step Cuts

NOTICE

A step cut is performed when a series of small cuts are used to complete a single cut.

1. Step cutting is the preferred method for all cuts.
2. When cutting large or hard material, step cutting should always be used.
3. Step cutting will extend the life of the diamond blade.

- Step cut setup: Depress Trigger (D8) to start (lock if desired). Hold work in position.
- Step cut “push” stroke: Using the Handle (D1), lower the Cutting Head 1/4-1/2 inch during the “push” stroke. Push the Casting Table (F1) away from you.
- Step cut “pull” stroke: Using the Handle (D1), lower the Cutting Head an additional 1/4-1/2 inch during the “pull” stroke. Pull the Casting Table (F1) towards you.
- Repeat “push” and “pull” strokes until the cut is complete.
- When the cut is complete, release the Trigger Switch (D8). Allow the Blade (H8) to stop before removing work. Using the Handle (D1), raise the Cutting Head.

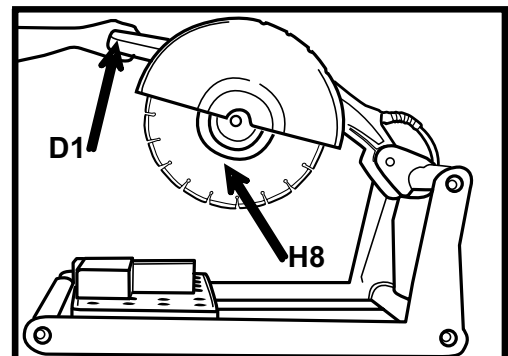
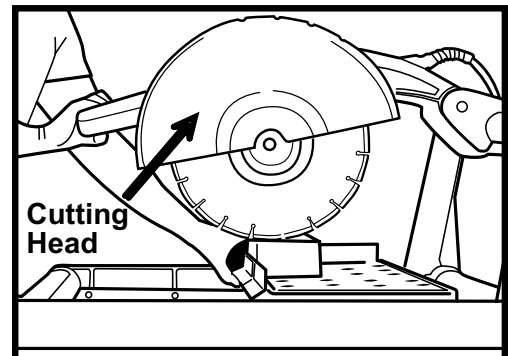
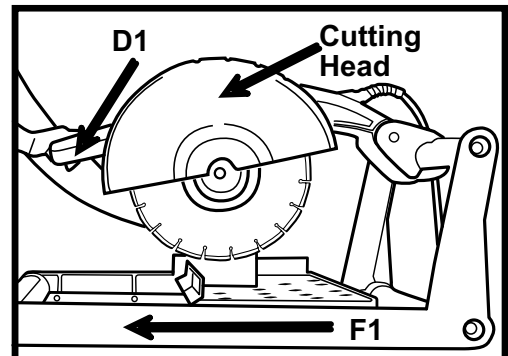
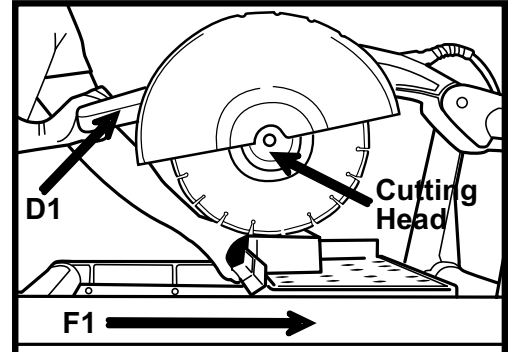
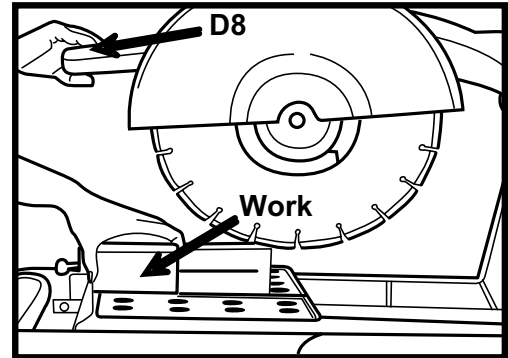

OPERATION

Chop cutting:

NOTICE

A chop cut is performed by cutting completely through an object in one pass.

- Chop cut setup: Depress Trigger (D8) to start (lock if desired). Position work below the Blade (H8).
- Hold Casting Table (F1) stationery. Using the Handle (D1), lower the Cutting Head to begin cutting.
- Using the Handle (D1), continue to lower the Cutting Head until the cut is complete.
- When the cut is complete, release the Trigger Switch (D8). Allow the Blade (H8) to stop before removing work. Using the Handle (D1), raise the Cutting Head.

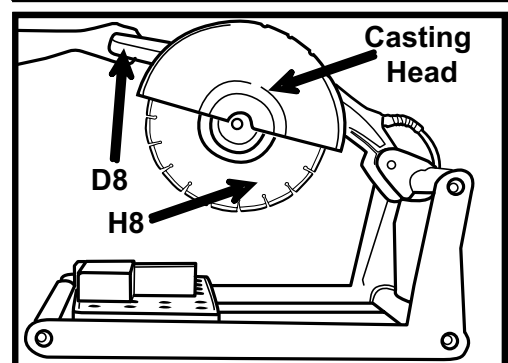
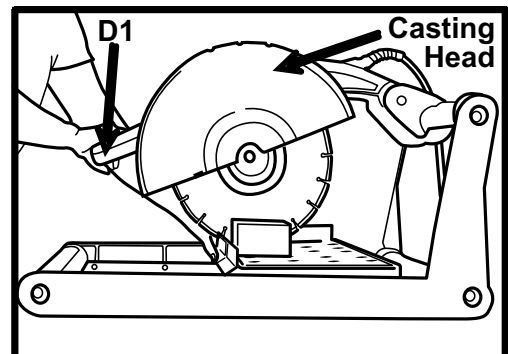
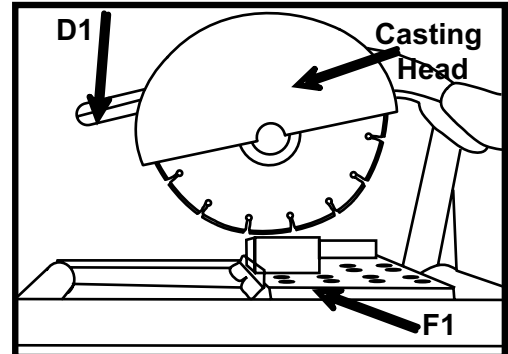
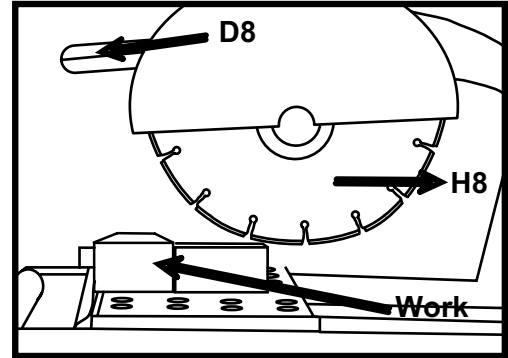

OPERATION

Cutting with the Cutting Head locked down

NOTICE

This method is preferred when cutting small objects.

- Align holes on the Pivot Clamp (C1). Insert the Pivot Pin (C4) to lock the Cutting Head in the down position.
- Locked Cutting Head setup: Lock the Trigger Switch (D8). Hold work in position.
- Slowly push the Casting Table (F1) towards the Blade (H8) to begin cutting.
- Continue to push work into the Blade (H8) until the cut is complete. Unlock the Trigger Switch (D8). Allow the Blade (H8) to stop moving before removing the work.
- When the cut is complete, hold the Handle (D1) in the down position. Remove the Pivot Pin (C4) to release the Cutting Head.

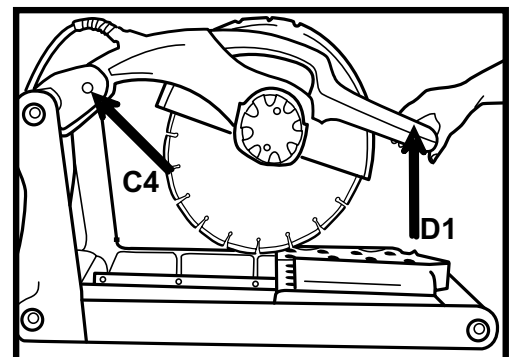
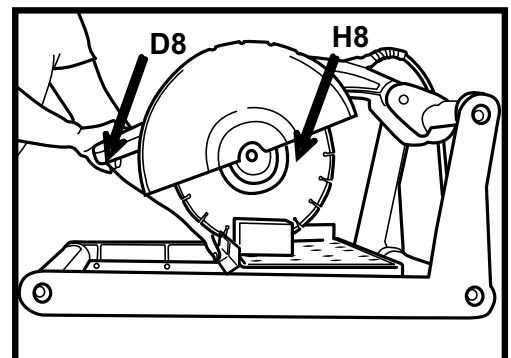
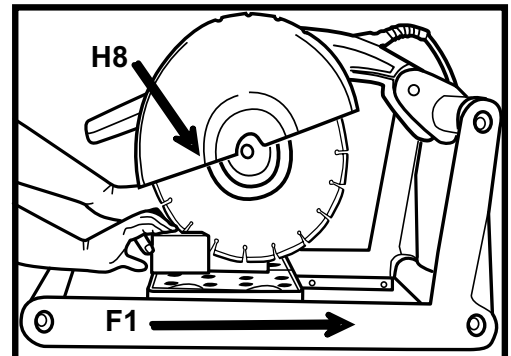
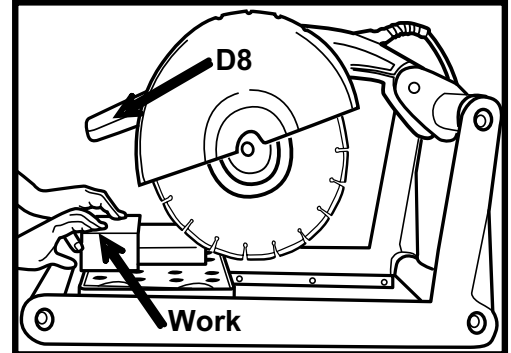
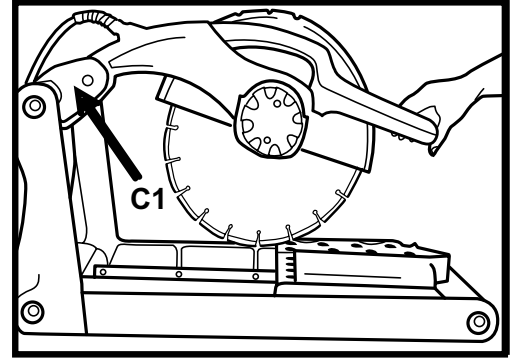

MAINTENANCE

General Maintenance:

NOTICE

Maintenance should be performed after each use. Use light oil when lubricating parts.

- Lubricate Torsion Spring (C6).

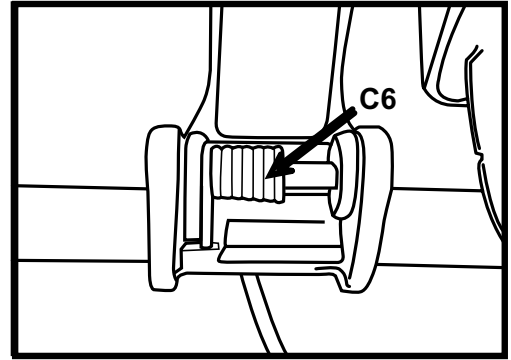

Monthly Maintenance:

NOTICE

Maintenance for these specified parts should be performed monthly.

- Clean and lubricate Inner Flange (E2) and Motor Shaft.
- Clean and lubricate the Blade Retaining Screw (E4)
- Check Roller Wheels (F5) and Guide Rails (A8) for wear or damage.

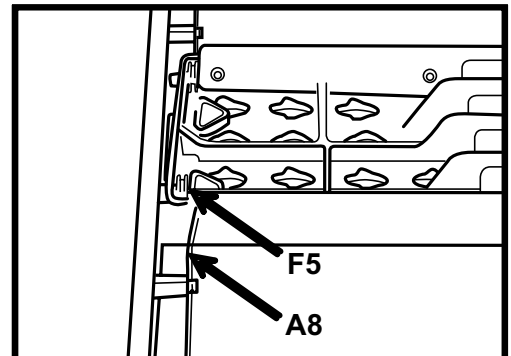
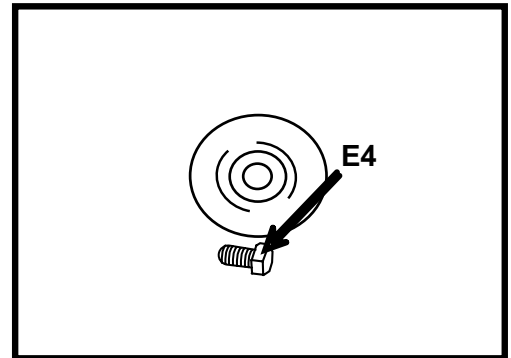
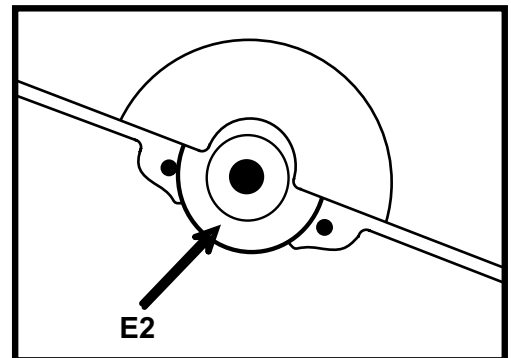

MAINTENANCE

Motor Brush change-out

WARNING!

Disconnect the tool before servicing and when changing accessories. Care must be taken to ensure the spring end is straight before installing the Motor Brush Cap.

- Insert a slotted screwdriver into the Motor Brush Cap (E8). Rotate counter-clockwise and remove the Cap. Repeat on the other side of the Motor.
- Remove the Motor Brush. Clean the Brush Housing of all carbon dust and fragments.
- Align a new Motor Brush with the Brush Housing. Insert the new Motor Brush.
- Replace the Motor Brush Cap (E8). Using the slotted screwdriver, rotate clockwise to secure in place.
- Using this same method, install a new Motor Brush on the other side of the Motor.

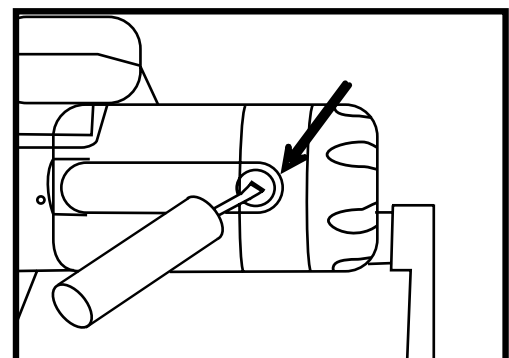
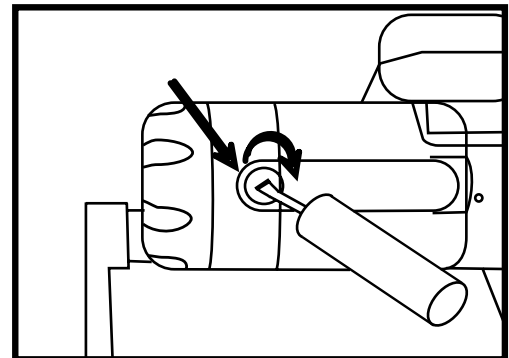
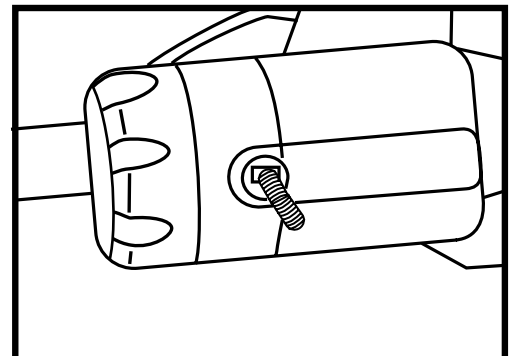
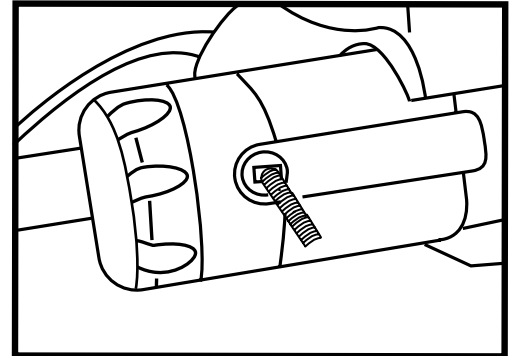
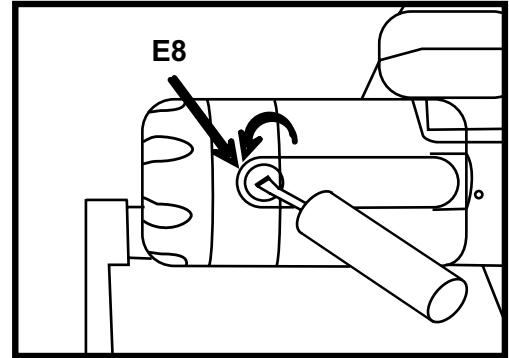

MAINTENANCE

 **WARNING!**

Never use fire bricks to “sharpen” or dress diamond blades!

 **WARNING!**

Abrasive blades must be a reinforced type!

Never use an abrasive blade with water!

Abrasive Blades can be damaged by operator abuse, such as jamming material into blade!

Important Advise:

- Never transport the saw with the cutting head positioned on the frame. The movement can knock the head out of alignment.
- When storing for an extended period of time, use a wire brush to remove hard, caked sludge. Clean and thoroughly lubricate moving parts so the next saw job is ready for operation.
- The blade must fit the arbor snugly - especially diamond blades. Otherwise, pounding will occur and this will seriously damage the blades. If the arbor shoulder is grooved where the diamond blade has bound in the cut as the shaft has continued to turn, the arbor must be replaced, or the blade life will be severely shortened.
- Blade flanges must be full diameter - minimum of 3" (76 mm). Replace worn flanges at once because undersized flanges shorten blade life and cause blade breakage.
- Check the conveyor cart condition on a regular basis. Replace the wheels and the wooden insert frequently.
- Be certain the cutting head is correctly aligned. Blade misalignment because of handling damage, or transporting the saw with the cutting head on the frame can seriously affect blade life.
- Replace noisy bearings immediately! Worn bearings will quickly destroy the blade.
- Diamond blades may need to be “sharpened”. Blades may be efficiently “dressed” with dressing sticks.

MAINTENANCE

PRE OPERATION CHECKLIST



Before leaving our factory, every machine is thoroughly tested. Follow the instructions strictly and your machine will give you long service in normal operating conditions.



Before starting up the machine, make sure you read this entire Operation's Manual and are familiar with the operation of the machine.

WITH MACHINE COLD AND SETTING LEVEL:

1. Electric Models: Verify all electrical connections are intact.

1 - 2 HOUR OPERATION CHECK LIST:



ALWAYS place the machine on a level surface with the engine/motor "OFF", the ignition switch set in the "OFF" position and disconnected from the power source before performing any maintenance. Let the machine cool down!

SCHEDULED MAINTENANCE QUICK REFERENCE:



Before performing any maintenance, **ALWAYS** place the machine on a level surface with the engine/motor "OFF" and the ignition switch set in the "OFF" position.

SERVICE DAILY:

1. Check blade guard for damage.
2. Check clamps for damage or looseness. Tighten or replace as necessary.

We carry out all repairs in the shortest possible time and at the most economical prices. See inside back cover for our address and telephone numbers.

The instructions for use found in this document are for information only and are not binding. As part of our product quality improvement policy, we reserve the right to make any and all technical modifications without prior notice.



The manufacturer accepts no responsibility caused by unsuitable use or modifications.

NOTES

SPECIFICATIONS

| Specifications | |
|-----------------------------|--------------------|
| MODEL NO. | TS 355B |
| TYPE | Electric |
| Blade Guard Capacity | 14.00" (356 mm) |
| Blade Shaft RPM: | 3500 |
| Max. Depth of Cut: | 5.0" (127 mm) |
| Blade Arbor Size: | 1.0" (25 mm) |
| Blade Shaft Drive: | Direct Drive |
| Blade Guard: | 14.00" (356 mm) |
| Conveyor Cart: | Cast Aluminum |
| Frame: | Aluminum |
| Weight Pounds (kg): | 50 lbs. (22.7 kg) |
| Saw Crated: | 30" X 22" X 18" |

| Power Source | |
|--|----------------|
| MODEL NO. | TS 355B |
| TYPE: | Electric |
| Engine / Motor: | Ryobi |
| Horsepower (kw): | 3 (2.2) |
| RPM: | 3500 |
| Voltage: | 115 |
| Cycle (Hz) / Current / Phase: | 60 / A.C. / 1 |
| Full Load Amps: | 15 |
| Starting Amps: | 188-95 |



Husqvarna Construction Products, North America
Corporate Office
17400 West 119th Street
Olathe, Kansas 66061

Customer Service: 800-288-5040
Customer Serv. Fax: 800-825-0028
Corporate Office: 913-928-1000
Corp. Office Fax: 913-438-7951

South Carolina

Customer Service: 800-845-1312
Customer Serv. Fax: 800-257-9284

Canada

Customer Service: 800-461-9589
Customer Serv. Fax: 800-728-1907

International

Customer Service: 913-928-1300
Customer Serv. Fax: 913-438-7938



DUST WARNING



Cutting, especially when DRY cutting, generates dust that comes from the material being cut, which frequently contains silica. Silica is a basic component of sand, quartz, brick clay, granite and numerous other minerals and rocks. Exposure to excessive amount of such dust can cause:

- Respiratory diseases (affecting your ability to breath), including chronic bronchitis, silicosis and pulmonary fibrosis from exposure to silica. These diseases may be fatal;
 - Skin irritation and rash; and
 - Cancer according to NTP* and IARC*
- * National Toxicology Program, International Agency for Research on Cancer

Take precautionary steps

- Avoid inhalation of and skin contact with dust, mist and fumes;
- Wet cut when feasible, to minimize dust;
- Wear and ensure that all bystanders wear appropriate respiratory protection such as dust masks designed to filter out microscopic particles. (See OSHA 29 CFR Part 1910.1200)

California Prop 65 Warning:

Use of this product can cause exposure to materials known to the State of California to cause cancer and/or birth defects or other reproductive harm.





www.husqvarnacp.com

542 20 11-05

