

## DS 50 AT

Reservdelar

Spare parts

Ersatzteile

Pieces de rechange

Piezas de repuesto

Ricambi

Peças sobresselente



No.	Pos.	Description	No.	Pos.	Description
501 38 90-01	C	NUT			
504 02 06-02	C	SHAFT HOLDER			
504 02 10-01	B	DECAL			
504 02 10-02	C	DECAL			
504 02 22-01	B	DRILL CARRIAGE 50X1			
504 03 04-02	C	BASE PLATE 50AT			
504 04 81-01	D	STOP SCREW 50 CPL			
504 04 82-01	D	WASHER			
504 04 84-01	D	STOP SCREW			
506 40 07-01	D	DRILL RACK 50AT			
506 40 08-02	A	KEYSET CPL			
506 40 08-03	A	MOTOR MOUNT 50 ASSY			
506 40 08-04	A	MOTOR MOUNT 50 CPL			
506 40 17-02	B	SHAFT CPL			
506 40 19-01	B	BUSHING KIT			
506 40 20-01	B	HANDLE CPL			
506 40 22-01	C	RETAINER CPL			
506 40 76-09	C	SHAFT HOLDER WITH WHEEL			
506 40 77-08	B	ADJUSTABLE LEVER CPL			
506 40 79-12	C	BASE PLATE 50AT NO WHEEL			
506 40 80-10	C	BASE PLATE 50AT ASSY			
506 40 86-03	E	TOOL KIT			
506 40 88-07	D	DRILL RACK 50AT ASSY			
506 40 89-02	B	BUSHING KIT			
506 40 90-07	B	DRILL CARRIAGE 50X1 ASSY			
531 14 06-11	B	WASHER			
531 14 06-18	C	ADJUSTMENT SCREW			
531 14 06-19	D	SCREW			
531 14 06-20	C	PLUG			
531 14 06-27	C	WASHER			
531 14 06-30	BC	NUT			
531 14 06-32	C	WASHER			
531 14 06-36	C	WASHER			
531 14 06-38	C	WASHER			
531 14 06-39	C	SCREW			
531 14 06-43	D	KNOB			
531 14 06-58	B	SCREW			
531 14 06-59	B	SCREW			
531 14 06-72	B	KNOB			
531 14 06-73	B	SPRING			
531 14 06-74	A	WEDGE			
531 14 06-81	A	SCREW			
531 14 06-82	A	HANDLE			
531 14 06-83	AB	NUT			
531 14 06-84	B	SLEEVE			
531 14 06-85	B	SCREW			
531 14 06-86	B	SCREW			
531 14 07-10	A	MOTOR MOUNT			
531 14 07-11	A	SCREW			
531 14 07-12	A	WASHER			
531 14 07-13	A	WASHER			
531 14 07-14	A	SCREW			
531 14 07-16	C	RETAINER			
531 14 07-21	C	SCREW			
531 14 07-22	C	WASHER			
531 14 07-23	C	SCREW			
531 14 07-28	C	WHEEL			
531 14 07-30	C	COVERPLATE			
531 14 07-33	C	SHAFT			
531 14 07-57	C	NUT			
531 14 07-62	E	L ALLEN KEY 8MM			
531 14 08-82	B	BUSHING			
544 12 85-02	B	DECAL			
544 21 89-01	B	HANDLE			
544 22 27-01	E	SPANNER 30MM			
544 22 27-02	E	SPANNER 24MM			
544 27 98-01	E	L ALLEN KEY 6MM			

**A** DS50 AT

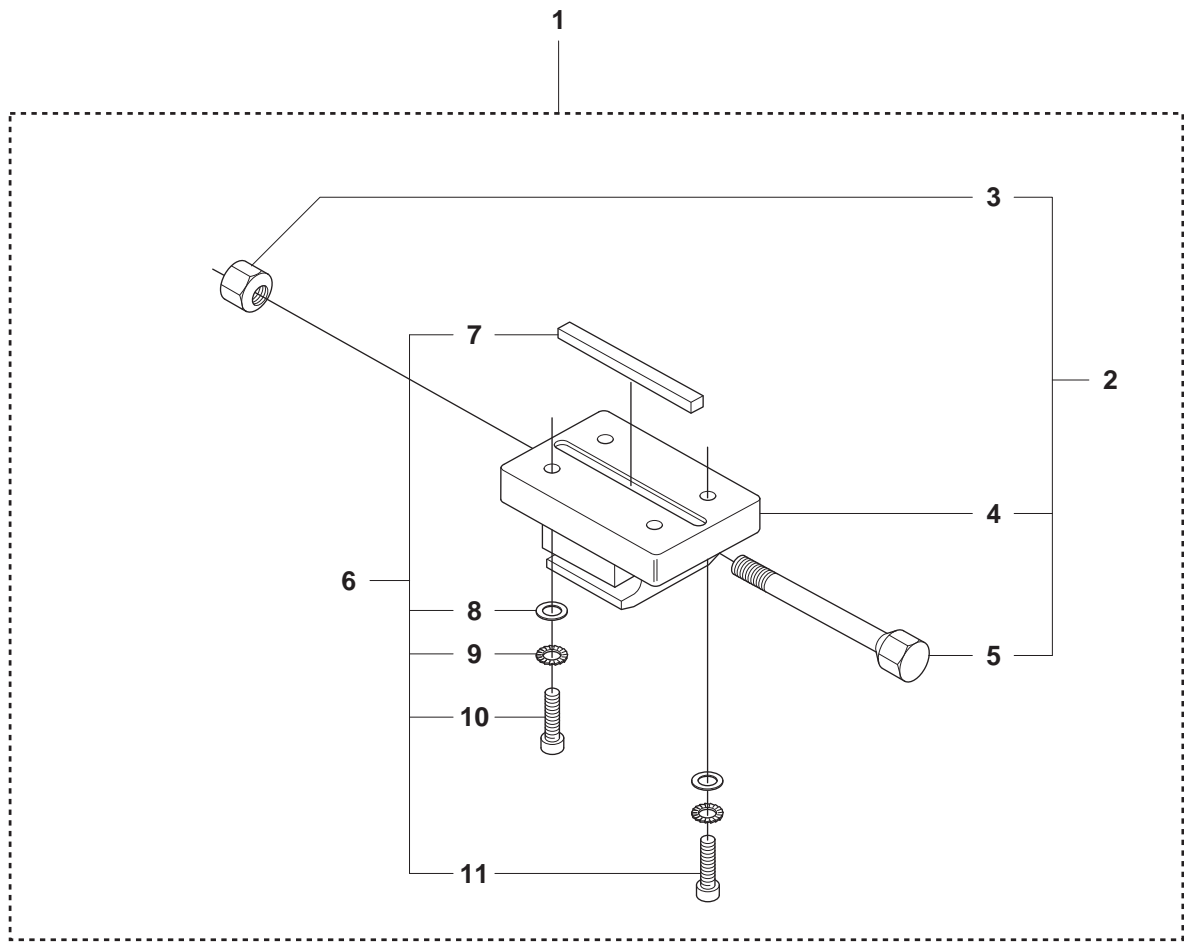

**Page A**  
**DS50AT**

<b>Pos.</b>	<b>Part No.</b>	<b>Description</b>	<b>Quantity</b>	<b>Notes</b>
1	506 40 08-03	MOTOR MOUNT 50 ASSY	1	Incl. 2, 6
2	506 40 08-04	MOTOR MOUNT 50 CPL	1	Incl. 3-5
3	531 14 06-83	NUT	1	
4	531 14 07-10	MOTOR MOUNT	1	
5	531 14 07-11	SCREW	1	
6	506 40 08-02	KEYSET CPL	1	Incl. 7-11
7	531 14 06-74	WEDGE	1	
8	531 14 07-12	WASHER	4	
9	531 14 07-13	WASHER	4	
10	531 14 06-81	SCREW	4	
11	531 14 07-14	SCREW	4	

**B**

DS50 AT

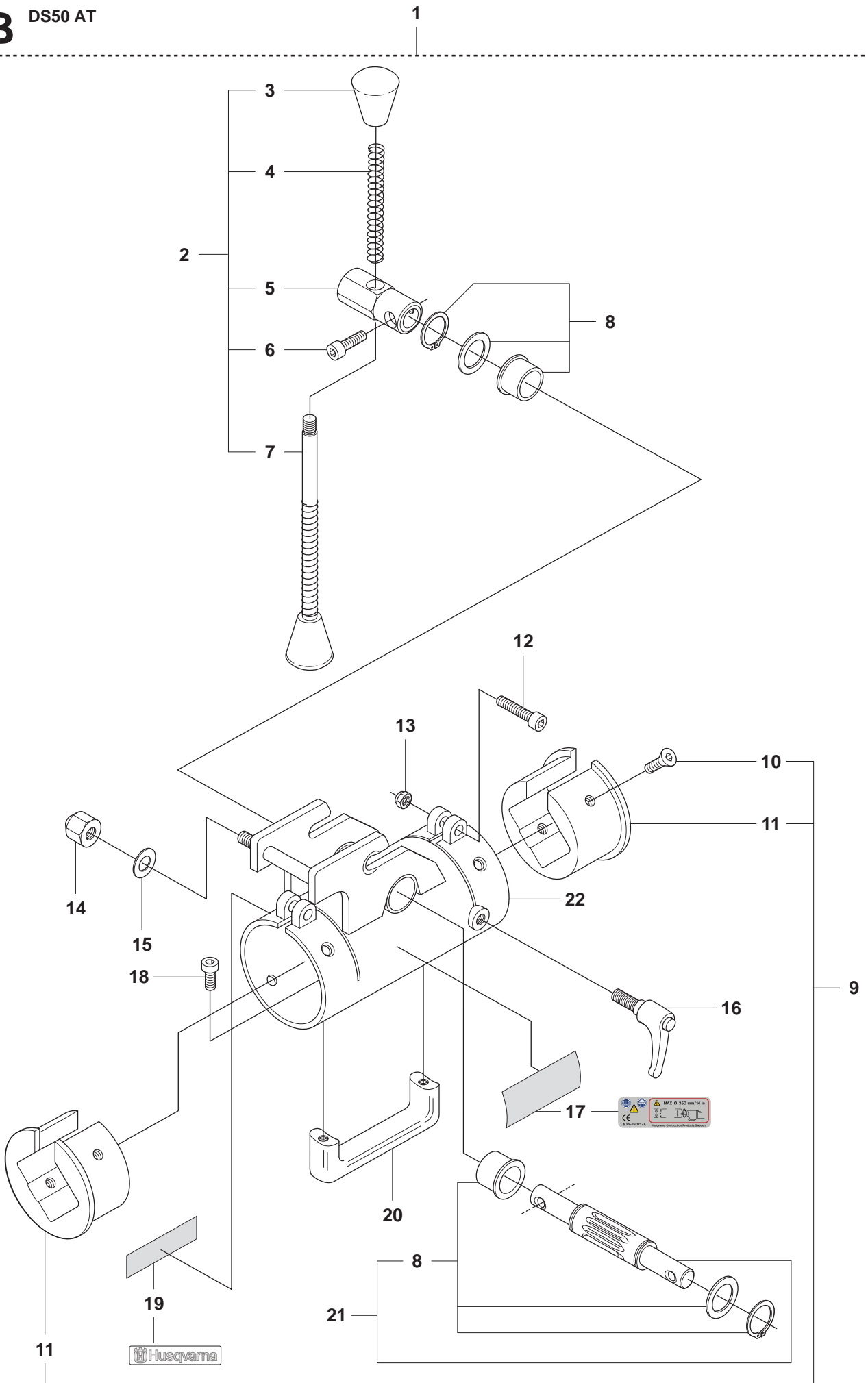

**Page B**  
**DS50AT**

<b>Pos.</b>	<b>Part No.</b>	<b>Description</b>	<b>Quantity</b>	<b>Notes</b>
1	506 40 90-07	DRILL CARRIAGE 50X1 ASSY	1	Incl. 2, 8, 9, 12-22
2	506 40 20-01	HANDLE CPL	1	Incl. 3-7
3	531 14 06-72	KNOB	2	
4	531 14 06-73	SPRING	2	
5	531 14 06-84	SLEEVE	1	
6	531 14 06-59	SCREW	1	
7	531 14 06-82	HANDLE	1	
8	506 40 19-01	BUSHING KIT	1	
9	506 40 89-02	BUSHING KIT	1	Incl. 10, 11
10	531 14 06-58	SCREW	8	
11	531 14 08-82	BUSHING	2	
12	531 14 06-86	SCREW	2	
13	531 14 06-30	NUT	2	
14	531 14 06-83	NUT	1	
15	531 14 06-11	WASHER	1	
16	506 40 77-08	ADJUSTABLE LEVER CPL	1	
17	544 12 85-02	DECAL	1	
18	531 14 06-85	SCREW	2	
19	504 02 10-01	DECAL	1	
20	544 21 89-01	HANDLE	1	
21	506 40 17-02	SHAFT CPL	1	Incl.8
22	504 02 22-01	DRILL CARRIAGE 50X1	1	

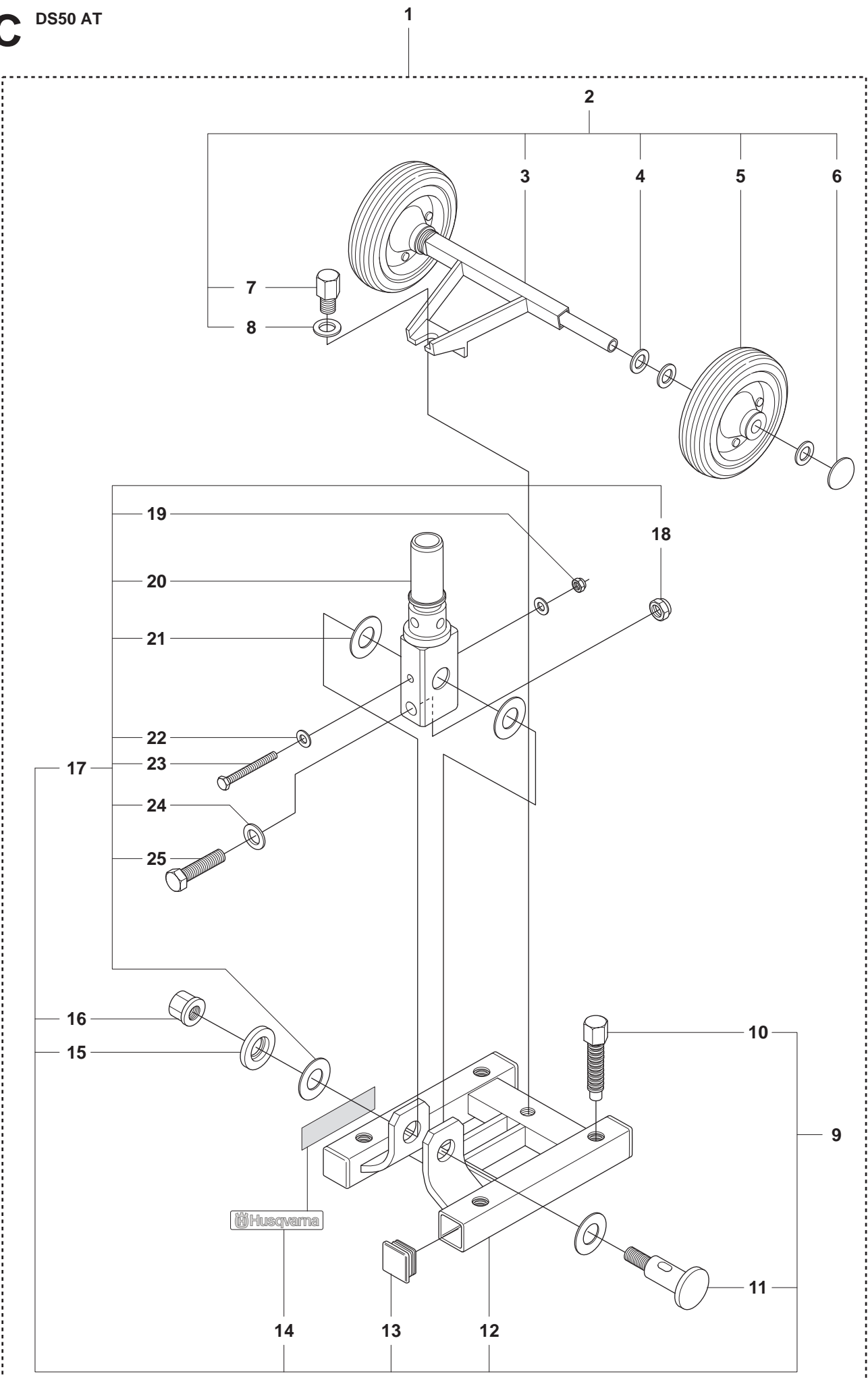



**Page C**  
**DS50AT**

<b>Pos.</b>	<b>Part No.</b>	<b>Description</b>	<b>Quantity</b>	<b>Notes</b>
1	506 40 80-10	BASE PLATE 50AT ASSY	1	Incl. 2, 9
2	506 40 76-09	SHAFT HOLDER WITH WHEEL	1	Incl. 3-8
3	504 02 06-02	SHAFT HOLDER	1	
4	531 14 06-27	WASHER	6	
5	531 14 07-28	WHEEL	2	
6	531 14 07-30	COVER PLATE	2	
7	531 14 07-23	SCREW	1	
8	531 14 07-22	WASHER	1	
9	506 40 79-12	BASE PLATE 50AT NO WHEEL	1	Incl. 10-17
10	531 14 06-18	ADJUSTMENT SCREW	4	
11	531 14 07-33	SHAFT	1	
12	504 03 04-02	BASE PLATE 50AT	1	
13	531 14 06-20	PLUG	4	
14	504 02 10-02	DECAL	1	
15	531 14 06-36	WASHER	1	
16	501 38 90-01	NUT	1	
17	506 40 22-01	RETAINER CPL	1	Incl. 18-25
18	531 14 07-57	NUT	1	
19	531 14 06-30	NUT	1	
20	531 14 07-16	RETAINER	1	
21	531 14 06-32	WASHER	4	
22	531 14 06-38	WASHER	2	
23	531 14 06-39	SCREW	1	
24	531 14 07-22	WASHER	1	
25	531 14 07-21	SCREW	1	

**D** DS50 AT

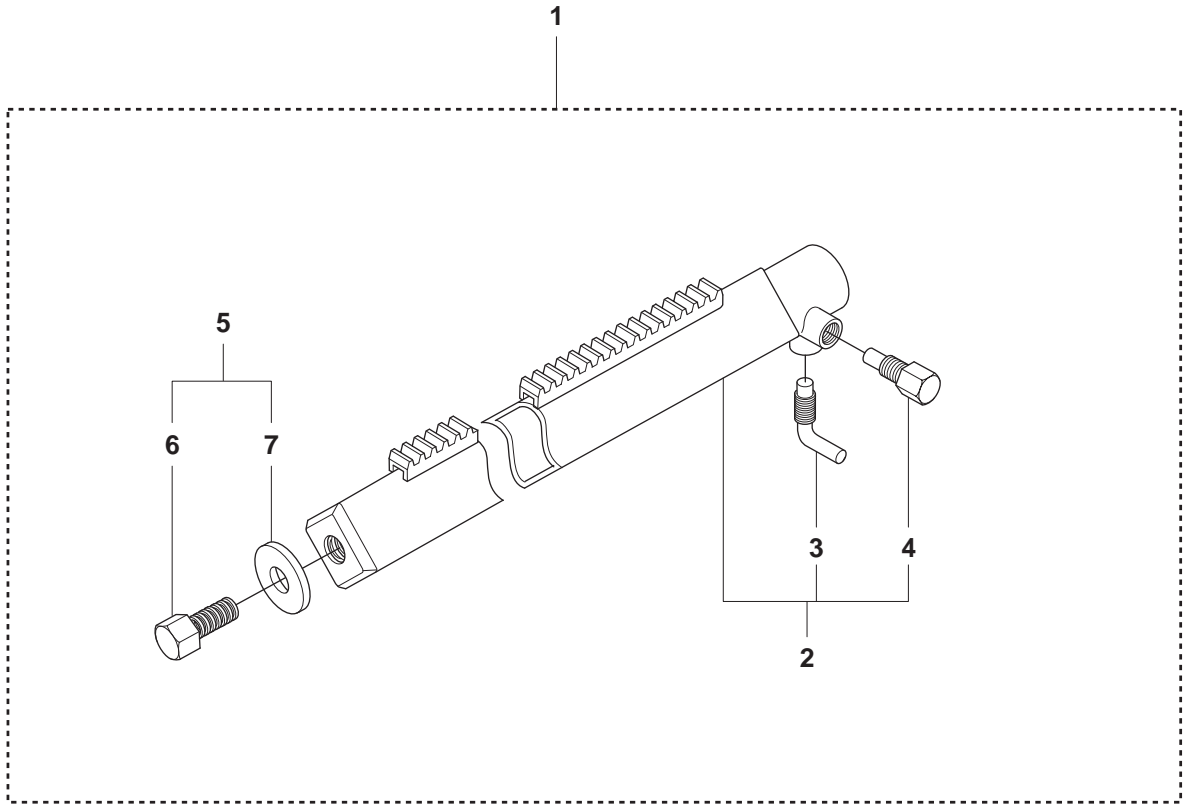

**Page D**  
**DS50AT**

<b>Pos.</b>	<b>Part No.</b>	<b>Description</b>	<b>Quantity</b>	<b>Notes</b>
1	506 40 88-07	DRILL RACK 50AT ASSY	1	Incl. 2, 5
2	506 40 07-01	DRILL RACK 50AT	1	Incl. 3, 4
3	531 14 06-43	KNOB	1	
4	531 14 06-19	SCREW	1	
5	504 04 81-01	STOP SCREW 50 CPL	1	Incl. 6, 7
6	504 04 84-01	STOP SCREW	1	
7	504 04 82-01	WASHER	1	

1

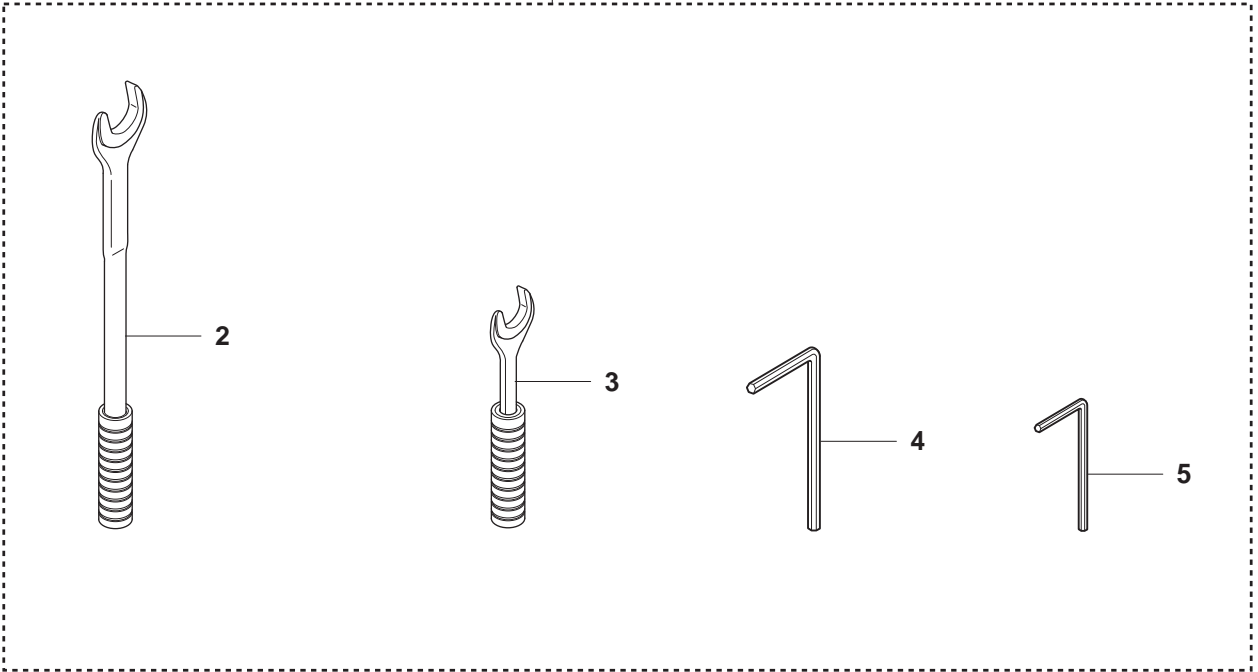

**Page E**  
**DS50AT**

<b>Pos.</b>	<b>Part No.</b>	<b>Description</b>	<b>Quantity</b>	<b>Notes</b>
1	506 40 86-03	TOOL KIT	1	Incl. 2-5
2	544 22 27-01	SPANNER 30MM	1	
3	544 22 27-02	SPANNER 24MM	1	
4	531 14 07-62	L ALLEN KEY 8MM	1	
5	544 27 98-01	L ALLEN KEY 6MM	1	