

DS50AT
DS50ATS

Reservdelar
Spare parts
Ersatzteile
Pieces de rechange
Piezas de repuesto
Ricambi
Peças sobresselente

No.	Pos.	Description	No.	Pos.	Description
501 38 46-04	C	HANDLE CPL	506 40 76-10	C	STABILIZER ASSY
501 38 47-02	C	SPRING	506 40 76-12	C	STABILIZER
501 38 60-02	C	SCREW	506 40 77-15	C	ADJUSTABLE LEVER CPL
504 01 81-02	C	HANDLE	531 14 06-18	A	ADJUSTMENT SCREW
504 02 09-01	C	FORK	531 14 06-20	A	PLUG
504 02 10-01	CD2	DECAL	531 14 06-24	AC	WHEEL
504 02 10-02	A	DECAL	531 14 06-23	AC	R-CLIP
504 04 82-01	B	WASHER	531 14 06-27	AC	WASHER
504 04 84-01	B	SCREW	531 14 06-30	D2	NUT
504 60 06-01	D1	GEAR WHEEL	531 14 06-58	D2	SCREW
504 60 06-02	D1	SHAFT	531 14 06-59	E	SCREW
504 69 63-01	E	SCREW	531 14 07-62	F	L ALLEN KEY 8MM
504 71 18-02	D1	SLEEVE	531 14 06-72	D1	GRIP
504 71 19-01	D1	WASHER	531 14 06-73	D1	SPRING
504 71 92-01	E	MOTOR MOUNT 50/70	531 14 06-75	C	SLEEVE
504 90 06-01	A	SCREW	531 14 06-76	C	WASHER
504 90 36-01	D1	SCREW	531 14 06-79	C	SCREW
504 90 49-01	D1	SHAFT	531 14 06-82	D1	LEVER
504 90 83-04	D1D2	SPRING	531 14 06-85	D2	SCREW
504 90 83-05	D1	BALL	531 14 06-86	D2	SCREW
504 90 83-07	D1	LID	531 14 07-12	E	WASHER
504 90 83-08	D1	BUSHING	531 14 07-35	C	SCREW
504 90 83-09	D1	SLEEVE	531 14 07-37	C	SLEEVE
504 90 83-10	D1	PIN	531 14 07-38	C	PLUG
504 90 83-12	D1	SCREW	531 14 07-39	C	SLEEVE
504 90 83-15	D1	WASHER	531 14 07-43	AC	LOCKING SCREW
504 90 83-16	D1	WASHER	531 14 08-82	D2	BUSHING
504 90 83-17	D1	KNOB	531 14 08-97	D1	LEVEL ROUND
504 90 83-18	D1	WASHER	531 14 08-98	D1	LEVEL SQUARE
504 90 83-19	D1	SCREW	544 12 85-02	D2	DECAL CE
504 90 83-21	D1	MOUNTING PLATE	544 22 27-01	F	SPANNER 30MM
504 90 83-22	D1	MOUNTING PLATE	544 22 27-02	F	SPANNER 24MM
504 90 83-23	D1	PIN	544 27 98-01	F	L ALLEN KEY 6MM
504 90 83-24	D1	SCREW			
504 90 83-25	D1	LOCK SLEDGE			
504 90 83-26	D1	PIN			
504 90 83-33	E	WEDGE			
504 90 83-35	D1	WASHER			
504 90 83-36	D1	WEDGE			
504 90 83-37	D1	BRACKET			
504 90 84-05	B	LOCKING SCREW			
504 90 91-02	A	WASHER			
504 90 91-05	A	LOCKING KNOB			
504 90 91-07	A	SCREW			
504 90 91-08	A	PIN			
504 90 91-09	A	SCREW			
504 90 91-13	A	SCREW			
504 90 91-12	A	SCREW			
504 90 91-14	A	SHAFT HOLDER			
505 40 03-01	D1D2	DRILL CARRIAGE 50 ASSY			
505 40 03-03	D1	SLEEVE			
505 40 03-04	D1	PLUG			
505 40 03-05	D1	HOLDER			
505 40 03-07	D1	MOUNTING BRACKET			
505 40 03-08	D1	SPRING			
505 40 03-09	D1	SLEEVE			
505 40 03-10	D1	MOUNTING BRACKET ASSY			
505 40 03-11	D2	DRILL CARRIAGE 50			
505 40 03-12	D2	HANDLE			
505 41 13-01	A	BASE PLATE 50AT/ATS ASSY			
505 41 13-02	A	CURLY BRACKET			
505 41 13-03	A	CLAMMER RING			
505 41 13-04	A	BRACKET			
505 41 13-05	A	LOCKING RING			
505 41 13-06	A	DECAL			
505 41 13-07	A	BASE PLATE 50AT/ATS			
505 41 14-01	B	DRILL RACK 50AT ASSY			
505 41 14-03	B	DRILL RACK 50AT/50ATS			
505 54 53-01	F	TOOL KIT			
506 40 08-07	E	MOTOR MOUNT 50/70 ASSY			

A

DS 50AT/DS 50ATS

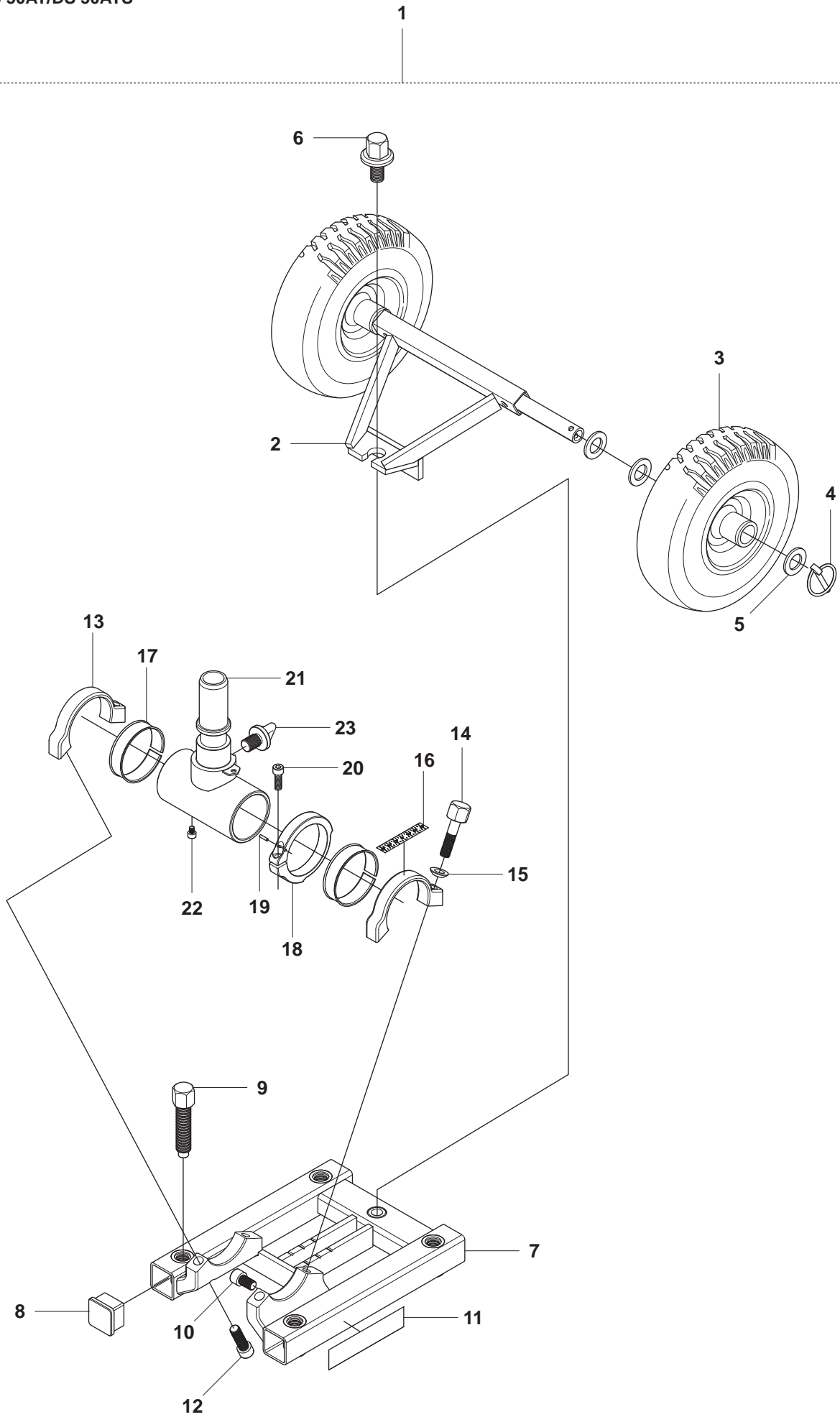

Page A**DS 50AT/DS 50ATS**

Pos.	Part No.	Description	Quantity	Notes
1	505 41 13-01	BASE PLATE 50AT/ATS ASSY	1	Incl. 2-23
2	504 90 91-14	SHAFT HOLDER	1	
3	531 14 06-24	WHEEL	2	
4	531 14 06-23	R-CLIP	2	
5	531 14 06-27	WASHER	6	
6	531 14 07-43	LOCKING SCREW	1	
7	505 41 13-07	BASE PLATE 50AT/ATS	1	
8	531 14 06-20	PLUG	4	
9	531 14 06-18	ADJUSTMENT SCREW	4	
10	504 90 91-13	SCREW	1	
11	504 02 10-02	DECAL	1	
12	504 90 91-12	SCREW	2	
13	505 41 13-02	CURLY BRACKET	2	
14	504 90 06-01	SCREW	2	
15	504 90 91-02	WASHER	2	
16	505 41 13-06	DECAL	1	
17	505 41 13-03	CLAMMER RING	2	
18	505 41 13-05	LOCKING RING	1	
19	504 90 91-08	PIN	1	
20	504 90 91-07	SCREW	1	
21	505 41 13-04	BRACKET	1	
22	504 90 91-09	SCREW	1	
23	504 90 91-05	LOCKING KNOB	1	

B

DS 50AT/DS 50ATS

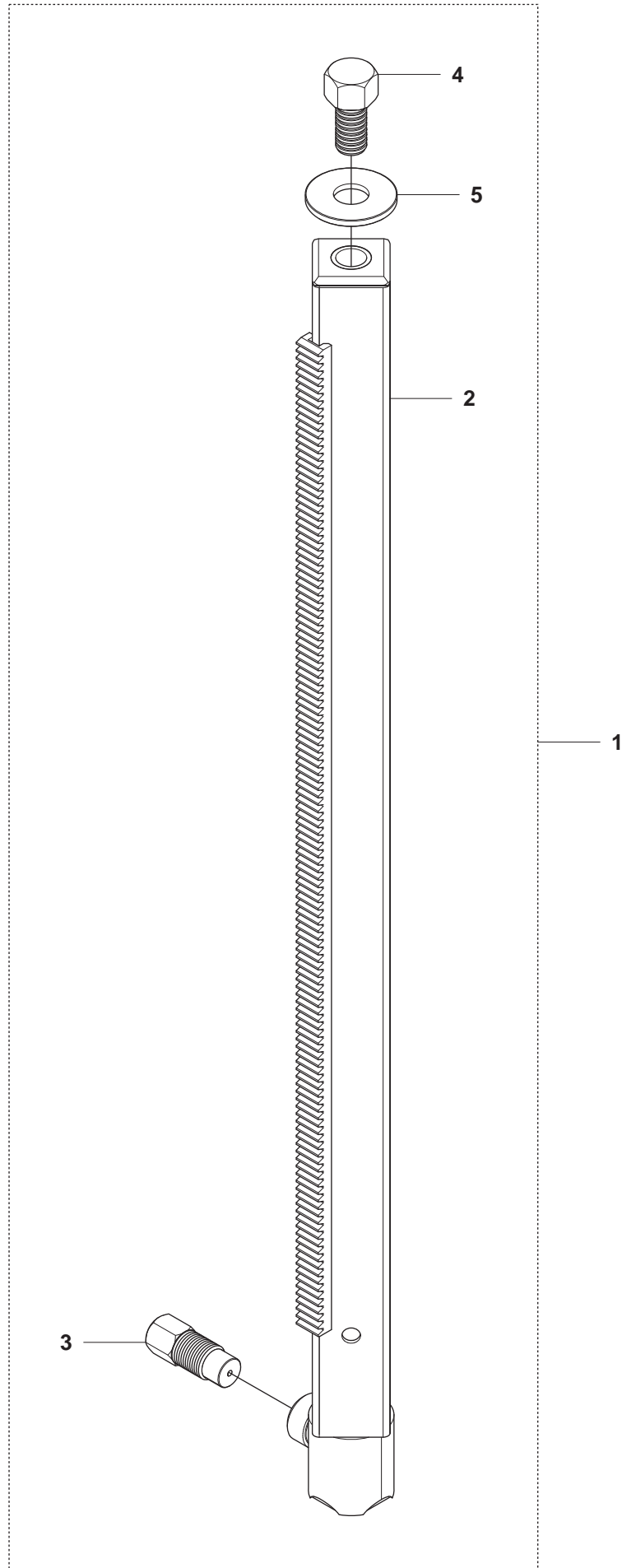

Page B

DS 50AT/DS 50ATS

Pos.	Part No.	Description	Quantity	Notes
1	505 41 14-01	DRILL RACK 50AT ASSY	1	Incl. 2-5
2	505 41 14-03	DRILL RACK 50AT/50ATS	1	
3	504 90 84-05	LOCKING SCREW	1	
4	504 04 84-01	SCREW	1	
5	504 04 82-01	WASHER,	1	

C DS 50ATS

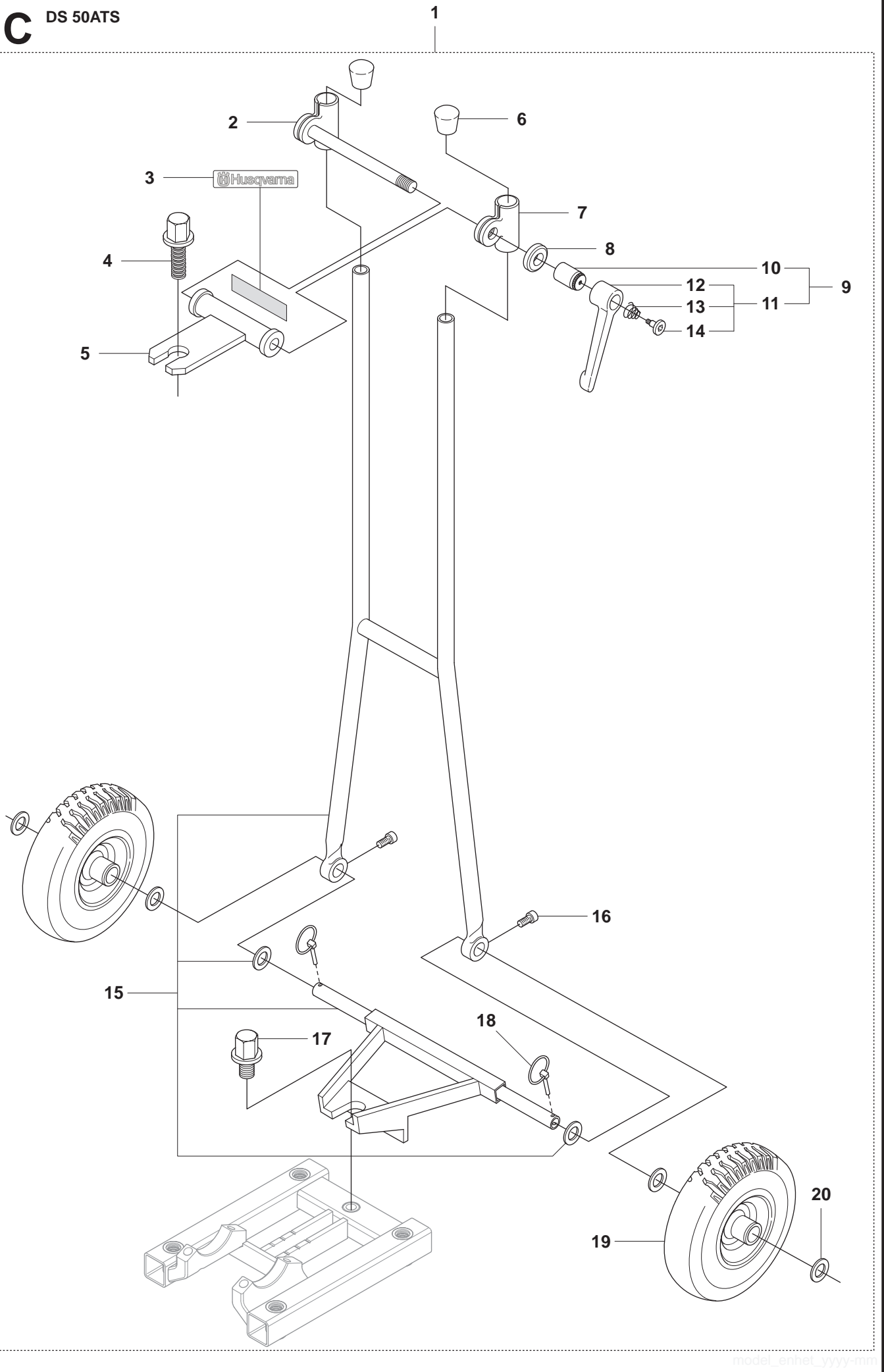

Page C
DS 50ATS

Pos.	Part No.	Description	Quantity	Notes
1	506 40 76-10	STABILIZER ASSY	1	Incl. 2-9, 15-20
2	531 14 07-37	SLEEVE	1	
3	504 02 10-01	DECAL	1	
4	531 14 07-35	SCREW	1	
5	504 02 09-01	FORK	1	
6	531 14 07-38	PLUG	2	
7	531 14 07-39	SLEEVE	1	
8	531 14 06-76	WASHER	1	
9	506 40 77-15	ADJUSTABLE LEVER CPL	1	Incl. 10, 11
10	531 14 06-75	SLEEVE	1	
11	501 38 46-04	HANDLE CPL	1	Incl. 12-14
12	504 01 81-02	HANDLE	1	
13	501 38 47-02	SPRING	1	
14	501 38 60-02	SCREW	1	
15	506 40 76-12	STABILIZER	1	
16	531 14 06-79	SCREW	2	
17	531 14 07-43	SCREW	1	
18	531 14 06-23	R-CLIP	2	
19	531 14 06-24	WHEEL	2	
20	531 14 06-27	WASHER	6	

D1 DS 50AT/DS 50ATS

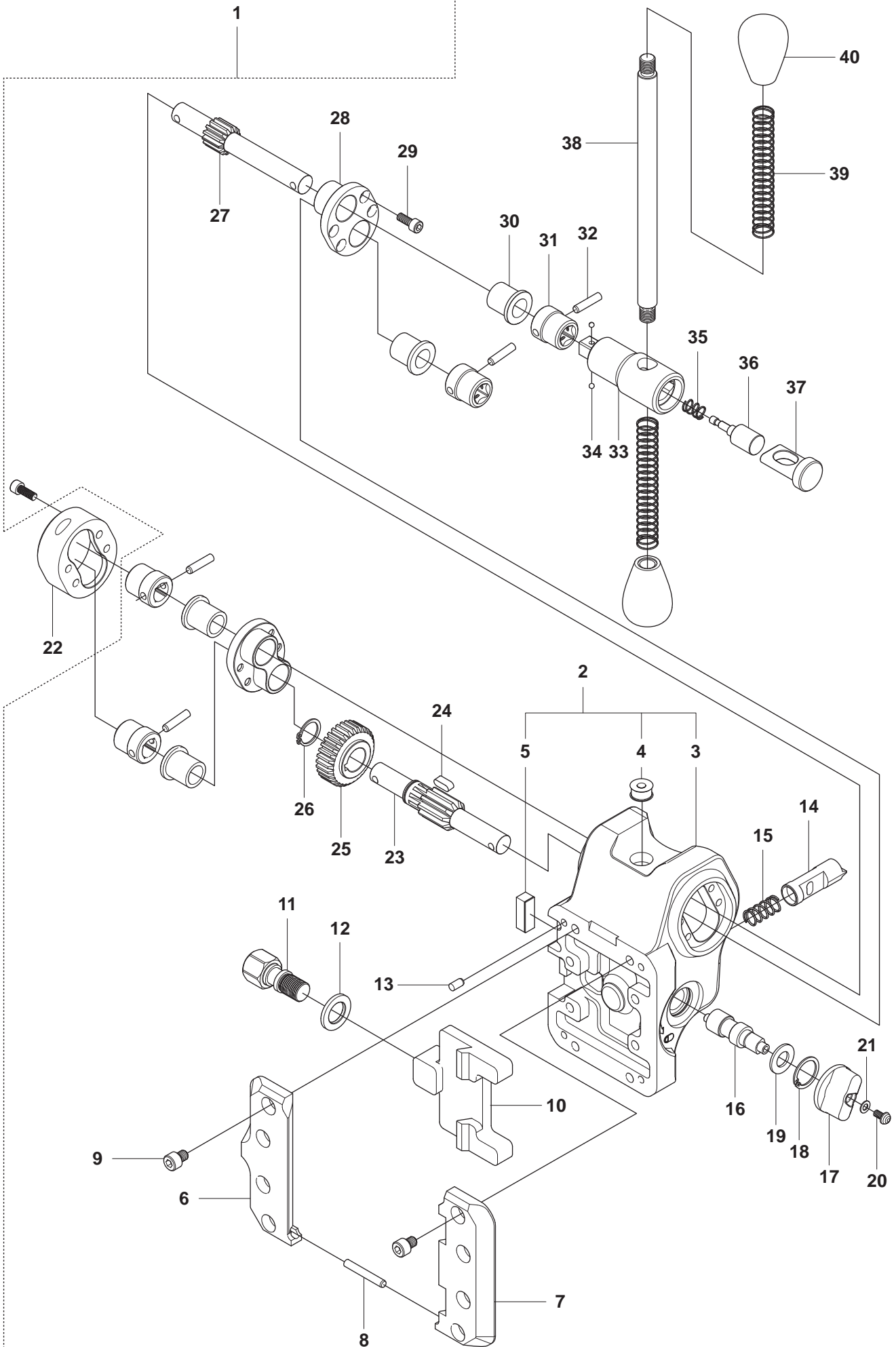

Page D1**DS 50AT/DS 50ATS**

Pos.	Part No.	Description	Quantity	Notes
1	505 40 03-01	DRILL CARRIAGE 50 ASSY	1	Incl. 2, 6-41 and 2-11 on Page D2
2	505 40 03-10	MOUNTING BRACKET ASSY	1	Incl. 3-5
3	505 40 03-07	MOUNTING BRACKET	1	
4	531 14 08-97	LEVEL ROUND	1	
5	531 14 08-98	LEVEL SQUARE	1	
6	504 90 83-22	MOUNTING PLATE	1	
7	504 90 83-21	MOUNTING PLATE	1	
8	504 90 83-23	PIN	1	
9	504 90 83-24	SCREW	8	
10	504 90 83-25	LOCK SLEDGE	1	
11	504 90 36-01	SCREW	1	
12	504 71 19-01	WASHER	1	
13	504 90 83-26	PIN	1	
14	504 71 18-02	SLEEVE	1	
15	505 40 03-08	SPRING	1	
16	505 40 03-09	SLEEVE	1	
17	504 90 83-17	KNOB	1	
18	504 90 83-16	WASHER	1	
19	504 90 83-15	WASHER	1	
20	504 90 83-19	SCREW	1	
21	504 90 83-18	WASHER	1	
22	504 90 83-37	BRACKET	0	Fitting for Autofeed, not included.
23	504 90 49-01	SHAFT	1	
24	504 90 83-36	WEDGE	1	
25	504 60 06-01	GEAR WHEEL	1	
26	504 90 83-35	WASHER	1	
27	504 60 06-02	SHAFT	1	
28	504 90 83-07	LID	2	
29	504 90 83-12	SCREW	8	
30	504 90 83-08	BUSHING	4	
31	504 90 83-09	SLEEVE	4	
32	504 90 83-10	PIN	4	
33	505 40 03-03	SLEEVE	1	
34	504 90 83-05	BALL	2	
35	504 90 83-04	SPRING	1	
36	505 40 03-04	PLUG	1	
37	505 40 03-05	HOLDER	1	
38	531 14 06-82	LEVER	1	
39	531 14 06-73	SPRING	2	
40	531 14 06-72	GRIP	2	

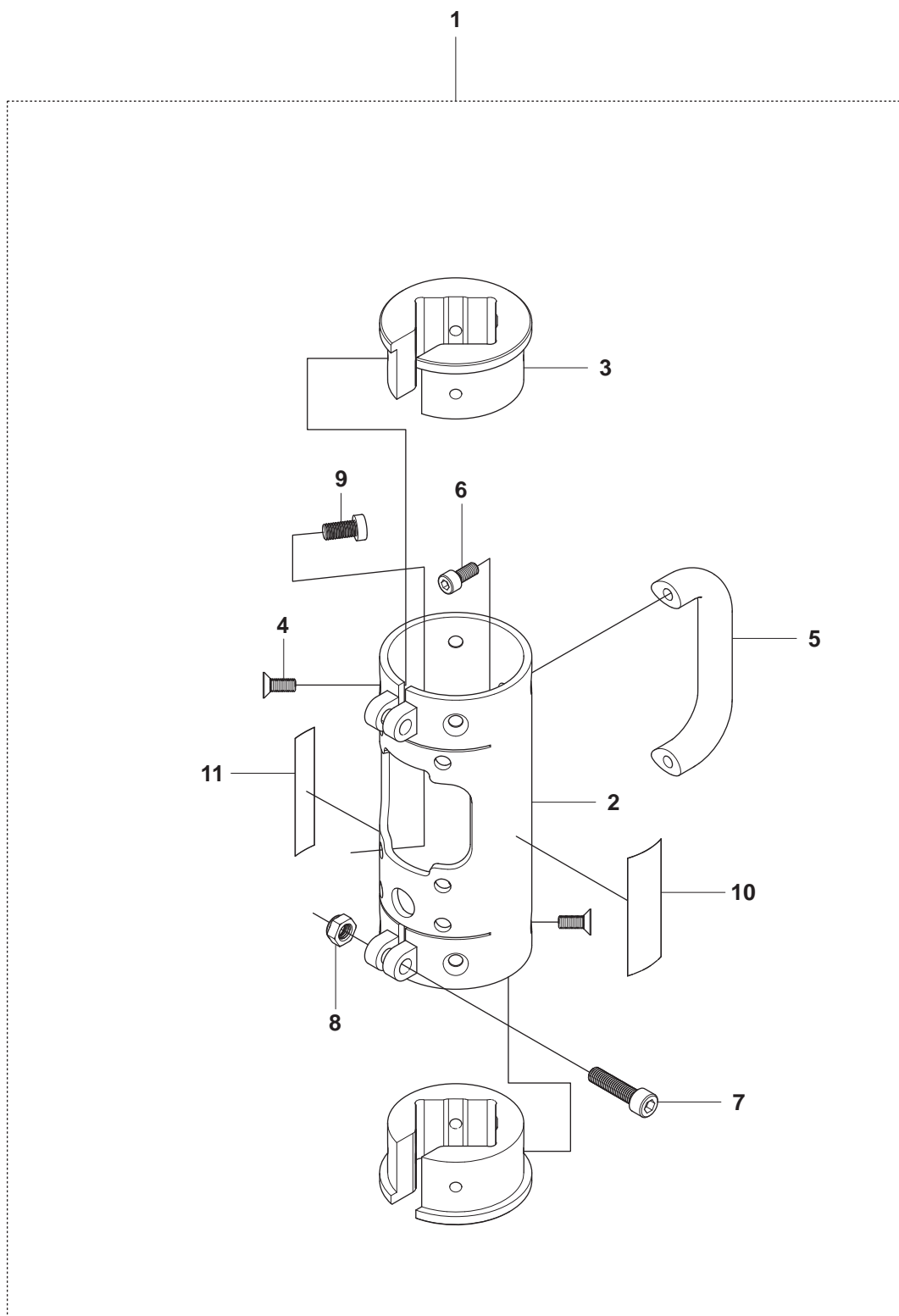

Page D2**DS 50AT/DS 50ATS**

Pos.	Part No.	Description	Quantity	Notes
1	505 40 03-01	DRILL CARRIAGE 50 ASSY	1	Incl. 2-11 and 2, 6-41 on Page D1
2	505 40 03-11	DRILL CARRIAGE 50	1	
3	531 14 08-82	BUSHING	2	
4	531 14 06-58	SCREW	8	
5	505 40 03-12	HANDLE	1	
6	531 14 06-85	SCREW	2	
7	531 14 06-86	SCREW	2	
8	531 14 06-30	NUT	2	
9	504 90 83-04	SCREW	6	
10	544 12 85-02	DECAL CE	1	
11	504 02 10-01	DECAL HUSQVARNA	1	

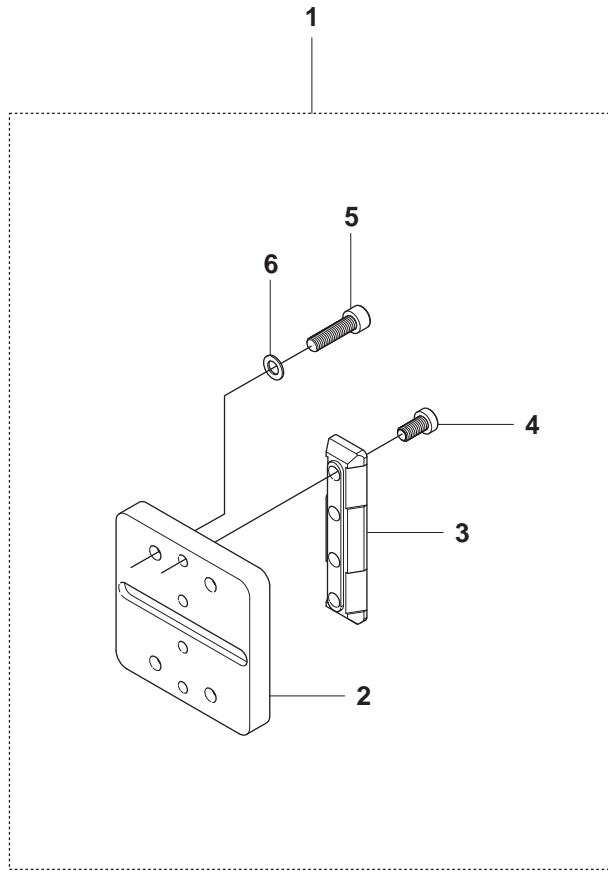

Page E**DS 50AT/DS 50ATS**

Pos.	Part No.	Description	Quantity	Notes
1	506 40 08-07	MOTOR MOUNT 50/70 ASSY	1	Incl. 2-6
2	504 71 92-01	MOTOR MOUNT 50/70	1	
3	504 90 83-33	WEDGE	1	
4	504 69 63-01	SCREW	4	
5	531 14 06-59	SCREW	4	
6	531 14 07-12	WASHER	4	

F DS 50AT/DS 50ATS
TOOLKIT

1

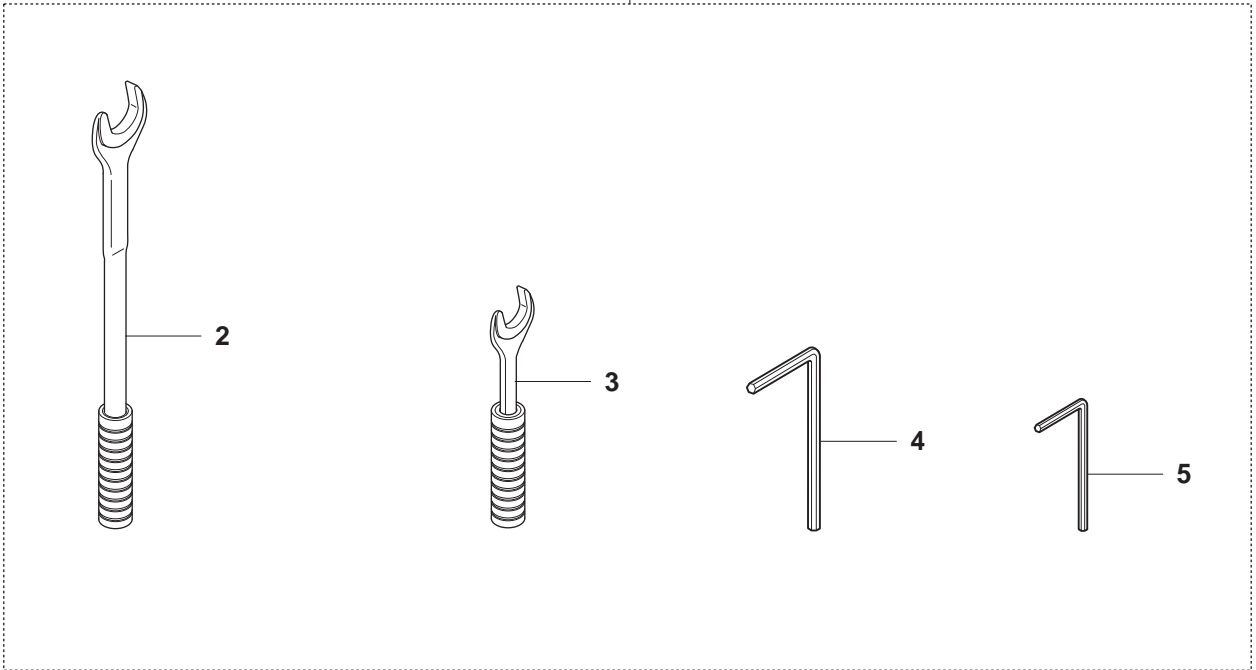

Page F

DS 50AT/DS 50ATS

Pos.	Part No.	Description	Quantity	Notes
1	505 54 53-01	TOOL KIT	1	Incl. 2-5
2	544 45 72-02	SPANNER 30MM	1	
3	544 22 27-02	SPANNER 24MM	1	
4	531 14 07-62	L ALLEN KEY 8MM	1	
5	544 27 98-01	L ALLEN KEY 6MM	1	