



# SPARE PARTS LIST

WALL SAWS

WS460, 2012-07

**J** WS 460  
 Tillbehör  
 Accessories  
 Zubehöre  
 Accessoires  
 Accesorios

Mounting bracket Universal  
 compl. 531 11 32-00

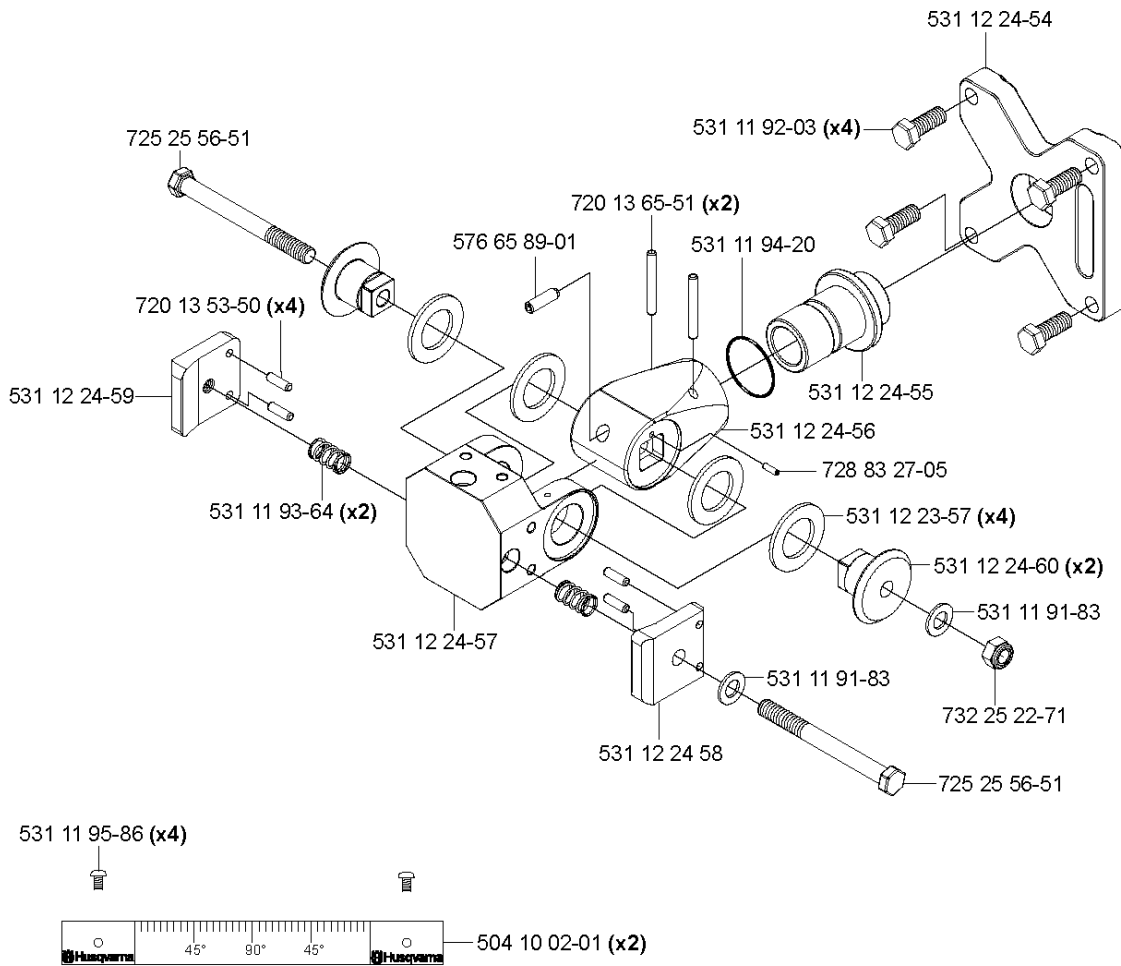

Measure rod complete 531 11 32-65

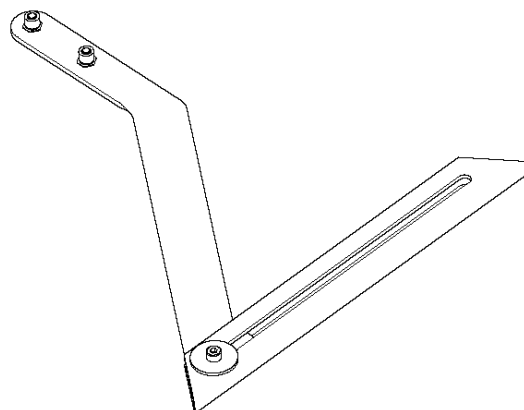

## ACCESSORIES

WS460, 2012-07

Part No	Description	Remark	QTY KIT
504 10 02-01	SCALE		2
531 11 32-00	BRACKET		1
531 11 32-65	POINTER		1
531 11 91-83	WASHER		1
531 11 92-03	SCREW		4
531 11 93-64	SPRING		2
531 11 94-20	O-RING		1
531 11 95-86	SCREW		4
531 12 23-57	CLUTCH		4
531 12 24-54	CONSOLE		1
531 12 24-55	AXLE		1
531 12 24-56	MOUNT		1
531 12 24-57	BRACKET		1
531 12 24-58	WASHER		1
531 12 24-59	NUT		1
531 12 24-60	CLUTCH		2
576 65 89-01	SCREW		1
720 13 53-50	PARALLEL PIN		4
720 13 65-51	PARALLEL PIN		2
725 25 56-51	SCREW EHHM		1
728 83 27-05	SCREW IHSETM		2
732 25 22-71	HEXAGON LOCKING NUT		1

**G** WS 460

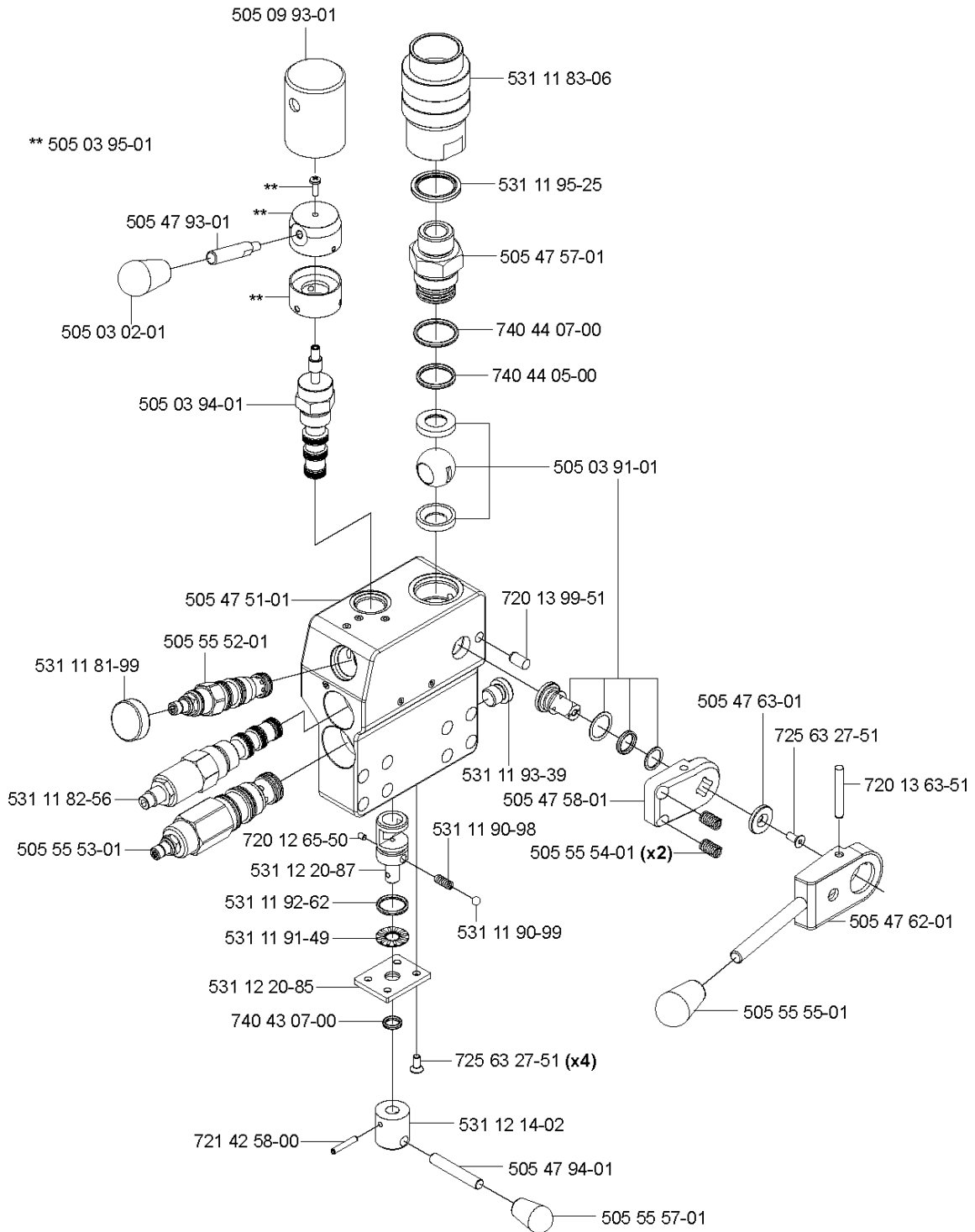

## ASSEMBLY

WS460, 2012-07

Part No	Description	Remark	QTY KIT
505 03 02-01	HANDLE		1
505 03 91-01	VALVE ASSY		1
505 03 94-01	VALVE		1
505 03 95-01	HANDLE		1
505 09 93-01	CUP		1
505 47 51-01	BLOCK		1
505 47 57-01	CONNECTION		1
505 47 58-01	BASEPLATE		1
505 47 62-01	HANDLE		1
505 47 63-01	LOCKWASHER		1
505 47 93-01	HANDLE		1
505 47 94-01	HANDLE		1
505 55 52-01	VALVE		1
505 55 53-01	VALVE		1
505 55 54-01	SPRING		2
505 55 55-01	HANDLE		1
505 55 57-01	HANDLE		1
531 11 81-99	KNOB		1
531 11 82-56	VALVE		1
531 11 83-06	COUPLING		1
531 11 90-98	SPRING		1
531 11 90-99	BALL		1
531 11 91-49	BEARING		1
531 11 92-62	O-RING		1
531 11 93-39	PLUG		1
531 11 95-25	SEALING RING		1
531 12 14-02	VALVE		1
531 12 20-85	COVER		1
531 12 20-87	VALVE		1
720 12 65-50	PARALLEL PIN		1
720 13 63-51	PEN		1
720 13 99-51	PEN		1
721 42 58-00	SPRING PIN		1
725 63 27-51	SCREW IHCSFM		4
740 43 07-00	O-RING		1
740 44 05-00	O-RING		1
740 44 07-00	O-RING		1

**E** WS 460

- Flange 1" complete 574 82 95-01
- Flange 60mm complete 574 82 95-02
- Flange 130 complete 574 82 95-03

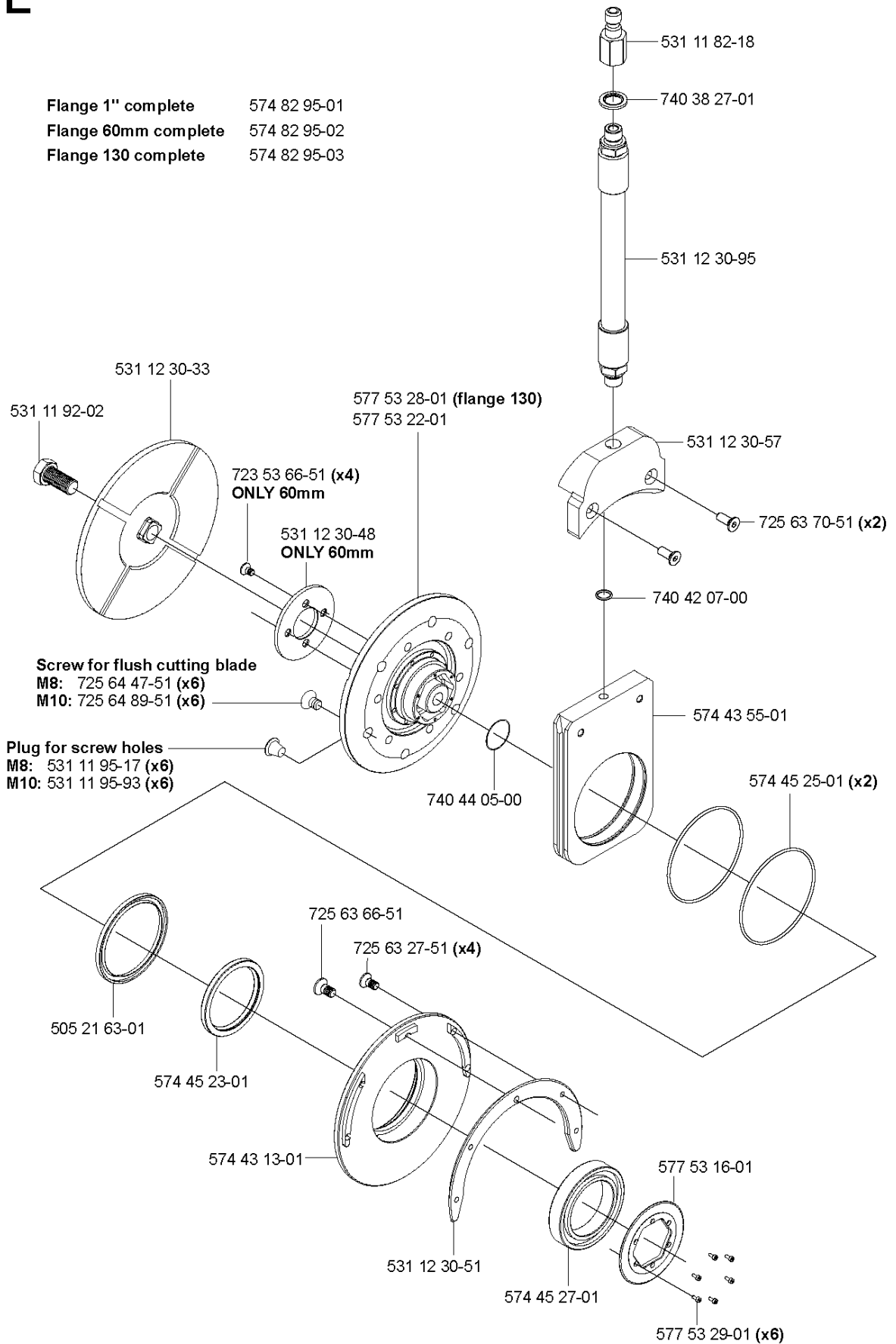

## BLADE FLANGE

WS460, 2012-07

Ref	Part No	Description	Remark	QTY KIT
531 11 82-18	531 11 82-18	QUICK COUPLING		1
531 11 92-02	531 11 92-02	SCREW		1
531 11 95-17	531 11 95-17	PLUG	M8	6
531 11 95-93	531 11 95-93	PLUG	M10	6
531 12 30-33	531 12 30-33	FLANGE		1
531 12 30-48	531 12 30-48	SPACER	Only 60mm	1
531 12 30-51	531 12 30-51	PLATE		1
531 12 30-57	531 12 30-57	WASSERANSCHLUSS		1
531 12 30-95	531 12 30-95	HOSE		1
574 43 13-01	574 43 13-01	HUB		1
574 43 55-01	574 43 55-01	BLOCK		1
574 45 23-01	574 45 23-01	SEAL		1
574 45 25-01	574 45 25-01	O-RING		2
574 45 27-01	574 45 27-01	BEARING		1
574 82 95-01	574 82 95-01	FLANGE		1
574 82 95-02	574 82 95-02	FLANGE		1
574 82 95-03	574 82 95-03	FLANGE		1
577 53 16-01	577 53 16-02	STOP WASHER		1
577 53 22-01	577 53 22-01	FLANGE		1
577 53 28-01	577 53 28-01	FLANGE	Flange 130	1
577 53 29-01	577 53 29-01	SCREW		6
723 53 66-51	723 53 66-51	SCREW	Only 60mm	4
725 63 27-51	725 63 27-51	SCREW IHCSFM		4
725 63 66-51	725 63 66-51	SCREW IHCSFM		1
725 64 47-51	725 64 47-51	SCREW IHCSFM	M8	6
725 64 89-51	725 64 89-51	SCREW IHCSFM	M10	6
740 38 27-01	740 38 27-01	SEALING WASHER		1
740 42 07-00	740 42 07-00	O-RING		1
740 44 05-00	740 44 05-00	O-RING		1
505 21 63-01	505 21 63-01	RADIAL SEAL		1
725 63 70-51	725 63 70-51	SCREW IHCSFM		2

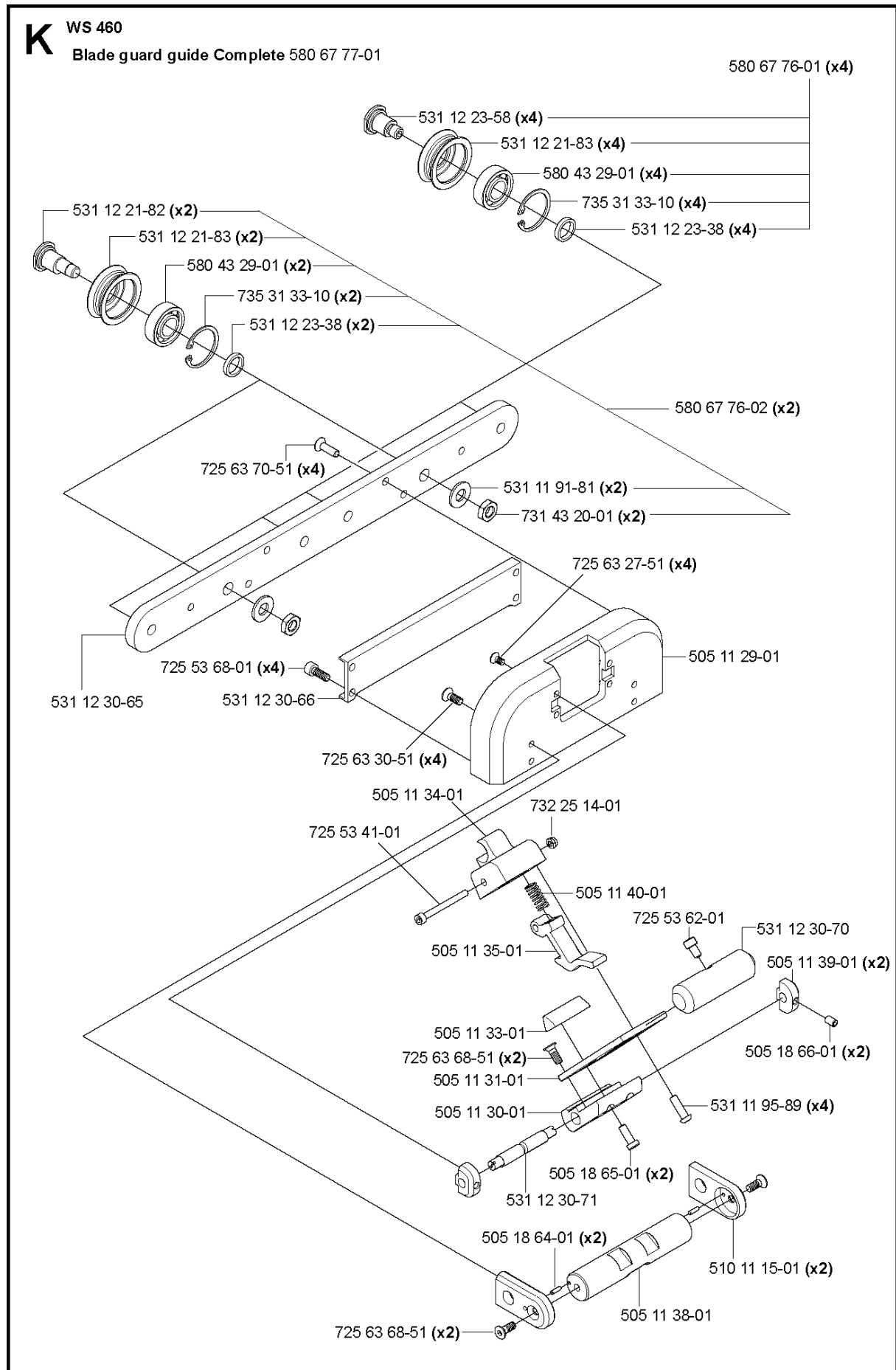



## BLADE GUARD GUIDE

WS460, 2012-07

Part No	Description	Remark	QTY KIT
505 11 29-01	HOLDER		1
505 11 30-01	ECCENTRIC		1
505 11 31-01	HANDLE BRACKET		1
505 11 33-01	BEAM		4
505 11 34-01	SNAP LOCKING		1
505 11 35-01	HOOK		1
505 11 38-01	HANDLE		1
505 11 39-01	SHAFT SEAT		2
505 11 40-01	SPRING		1
505 18 64-01	PARALLEL PIN		1
505 18 65-01	SCREW		1
505 18 66-01	SCREW		2
510 11 15-01	HANDLE HOLDER		2
531 11 91-81	WASHER		2
531 11 95-89	SCREW		4
531 12 21-82	WHEEL		2
531 12 21-83	WHEEL		2
531 12 23-38	SPACER RING		2
531 12 23-58	WHEEL		2
531 12 30-65	GUIDE RAIL		1
531 12 30-66	COVER		1
531 12 30-70	HANDLE		1
531 12 30-71	SHAFT		1
580 43 29-01	BEARING		2
580 67 76-01	WHEEL ASSY		1
580 67 76-02	WHEEL ASSY		2
580 67 77-01	BLADE GUARD		1
725 53 41-01	SCREW IHSCM		1
725 53 62-01	SCREW IHSCM		1
725 53 68-01	SCREW IHSCM		4
725 63 27-51	SCREW IHCSFM		4
725 63 30-51	SCREW IHCSFM		4
725 63 68-51	SCREW IHCSFM		2
725 63 70-51	SCREW IHCSFM		1
731 43 20-01	HEXAGON THIN NUT		2
732 25 14-01	HEXAGON LOCKING NUT		1
735 31 33-10	CIRCLIP		2

**R**

WS 460

Crank complete 506 49 35-01

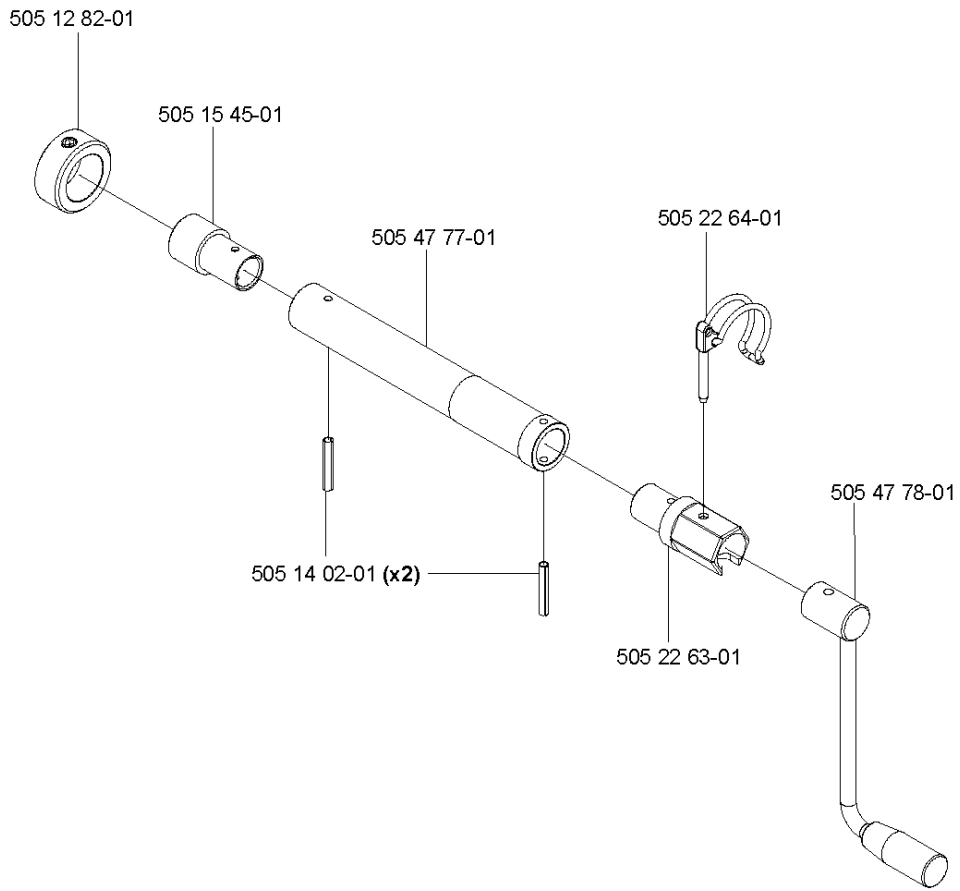

WS 460

Tillbehör  
Accessories  
Zubehöre  
Accessoires  
Accesorios

Angle adapter complete 505 32 13-01

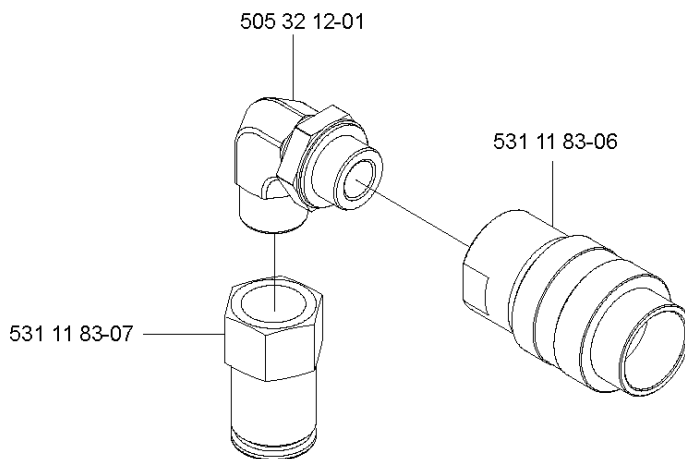

## CRANKSHAFT

WS460, 2012-07

Part No	Description	Remark	QTY KIT
505 12 82-01	RING		1
505 14 02-01	SPRING PIN		1
505 15 45-01	ADAPTER		1
505 22 63-01	ADAPTER		1
505 22 64-01	PIN		1
505 32 12-01	ADAPTER		1
505 32 13-01	ADAPTER		1
505 47 77-01	TUBE		1
505 47 78-01	CRANK		1
506 49 35-01	CRANK		1
531 11 83-06	COUPLING		1
531 11 83-07	COUPLING		1

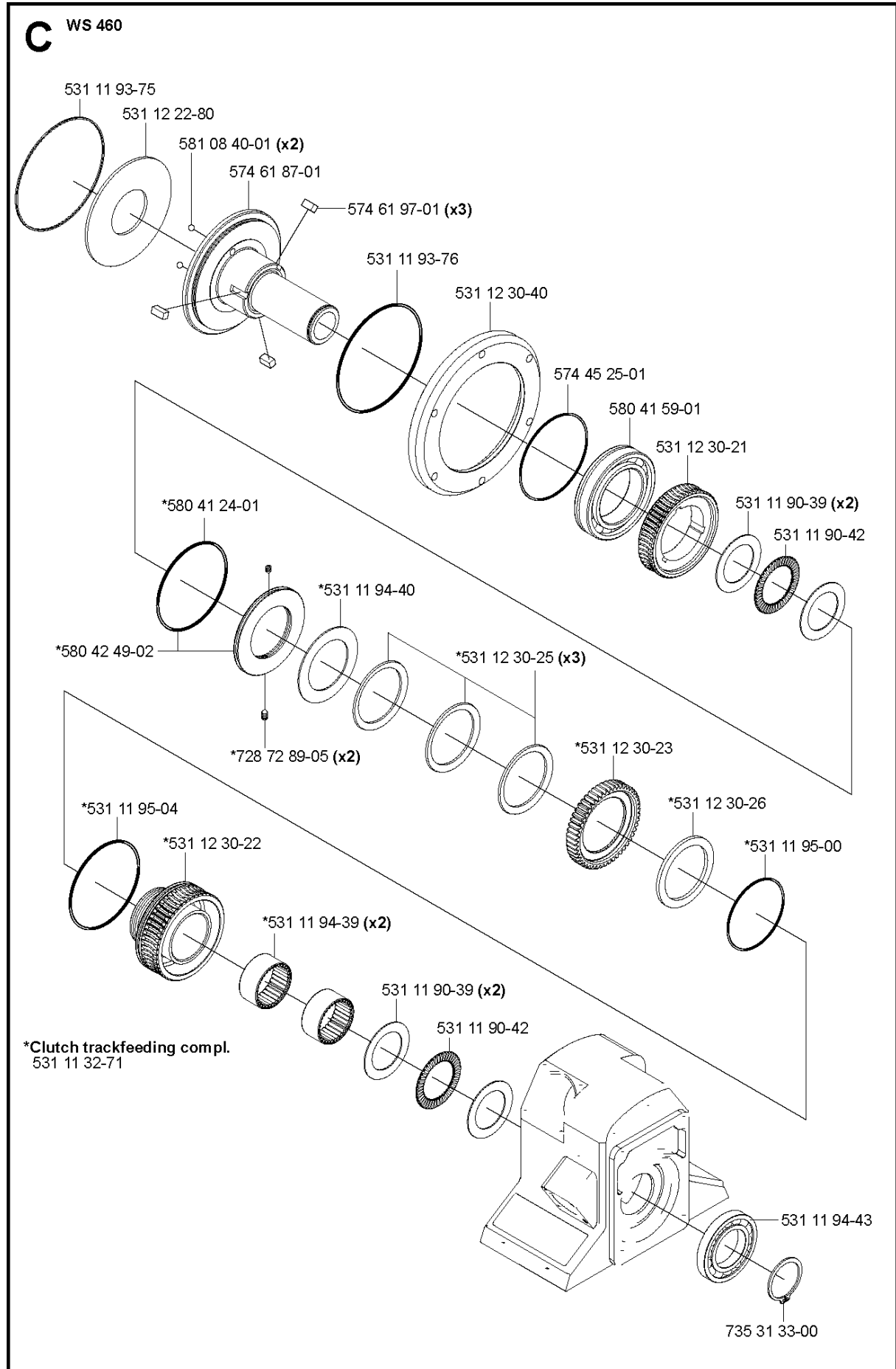

## FEEDING GEARS

WS460, 2012-07

Ref	Part No	Description	Remark	QTY KIT
531 11 32-71	531 11 32-71	CLUTCH		1
531 11 90-39	531 11 90-39	WASHER		2
531 11 90-42	531 11 90-42	BEARING		1
531 11 93-75	531 11 93-75	O-RING		1
531 11 93-76	531 11 93-76	O-RING		1
531 11 94-39	531 11 94-39	BEARING		2
531 11 94-40	531 11 94-40	BEARING		1
531 11 94-43	531 11 94-43	BEARING		1
531 11 95-00	531 11 95-00	O-RING		1
531 12 22-80	531 12 22-80	PLATE		1
531 12 30-21	531 12 30-21	GEAR WHEEL		1
531 12 30-22	591 18 70-01	GEAR WHEEL	Incl. Plate	1
531 12 30-23	531 12 30-23	GEAR WHEEL		1
531 12 30-25	531 12 30-25	CUP		3
531 12 30-26	531 12 30-26	PLATE		1
531 12 30-40	531 12 30-40	WASHER		1
574 61 87-01	574 61 87-01	SHAFT		1
574 61 97-01	574 61 97-01	KEY		3
580 41 24-01	580 41 24-01	O-RING		1
580 42 49-02	580 42 49-02	NUT		1
728 72 89-05	728 72 89-05	SCREW IHSETM		2
735 31 33-00	735 31 33-00	CIRCLIP		1
738 21 10-04	738 21 10-04	BALL BEARING		1
531 11 95-04	531 11 95-04	O-RING		1
581 08 40-01	581 08 40-01	BALL		1
580 41 59-01	580 41 59-01	BEARING		1
574 45 25-01	574 45 25-01	O-RING		1
531 11 95-01	531 11 95-01	SCREW		1

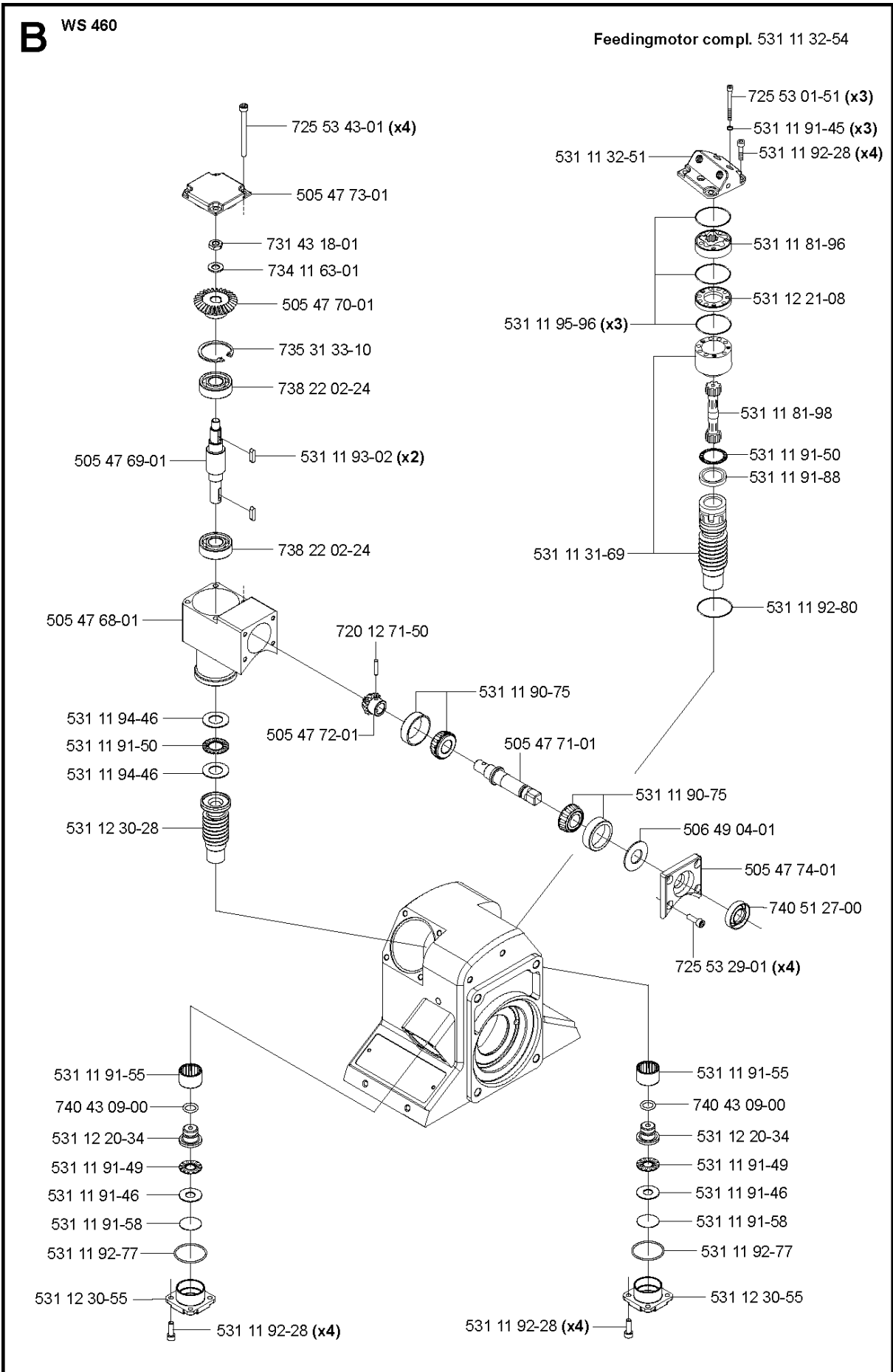

## FEEDING MOTORS

WS460, 2012-07

Part No	Description	Remark	QTY KIT
505 47 68-01	GEAR HOUSING		1
505 47 69-01	SHAFT		1
505 47 70-01	BEVEL GEAR		1
505 47 71-01	SHAFT		1
505 47 72-01	BEVEL GEAR		1
505 47 73-01	LID		1
505 47 74-01	PLATE		1
506 49 04-01	CUP		1
531 11 31-69	WORM GEAR		1
531 11 32-51	HOLDER ASSY		1
531 11 32-54	MOTOR		1
531 11 81-96	MOTOR		1
531 11 81-98	DRIVE SHAFT		1
531 11 90-75	BEARING		1
531 11 91-45	WASHER		3
531 11 91-46	BEARING		1
531 11 91-49	BEARING		1
531 11 91-50	BEARING		1
531 11 91-55	BEARING		1
531 11 91-58	SHIM		1
531 11 91-88	SEALING		1
531 11 92-28	SCREW		4
531 11 92-77	O-RING		1
531 11 92-80	O-RING		1
531 11 93-02	KEY		2
531 11 94-46	WASHER		1
531 11 95-96	O-RING		3
531 12 20-34	AXLE		1
531 12 21-08	HUB CAP		1
531 12 30-28	AUTOMATIC FEEDING SYSTEM		1
531 12 30-55	BLOCK		1
720 12 71-50	PARALLEL PIN		1
725 53 01-51	SCREW IHSCM		3
725 53 29-01	SCREW IHSCM		4
725 53 43-01	SCREW		4
731 43 18-01	HEXAGON THIN NUT		1
734 11 63-01	WASHER		1
735 31 33-10	CIRCLIP		1
738 22 02-24	BALL BEARING		1
740 43 09-00	O-RING		1
740 51 27-00	SEALING RING		1

# M2

WS 460

Flush blade guard 1000mm complete 577 74 24-01

**Gable section flush, RIGHT compl.**  
577 74 32-01

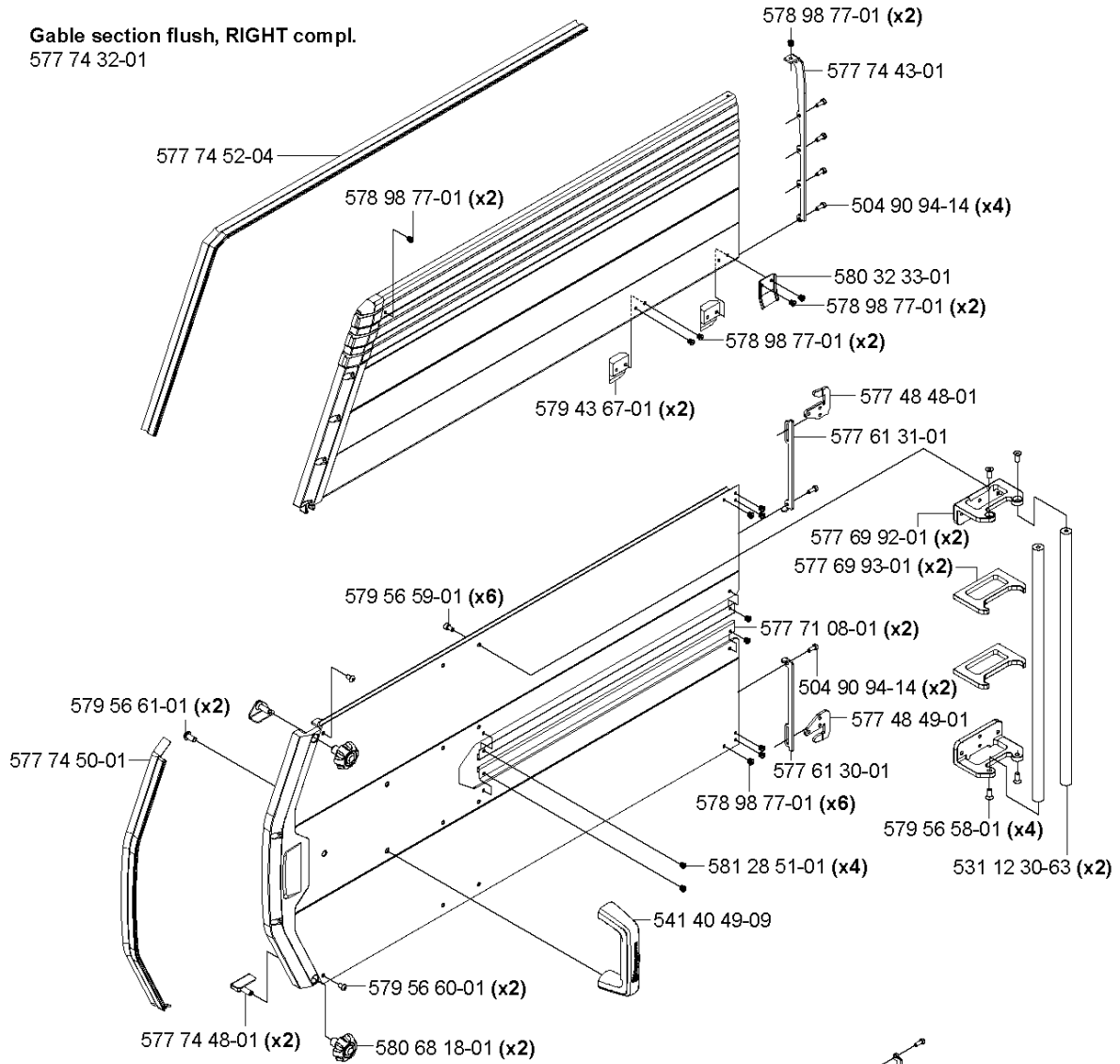

**Centre section flush compl.**  
577 90 30-01

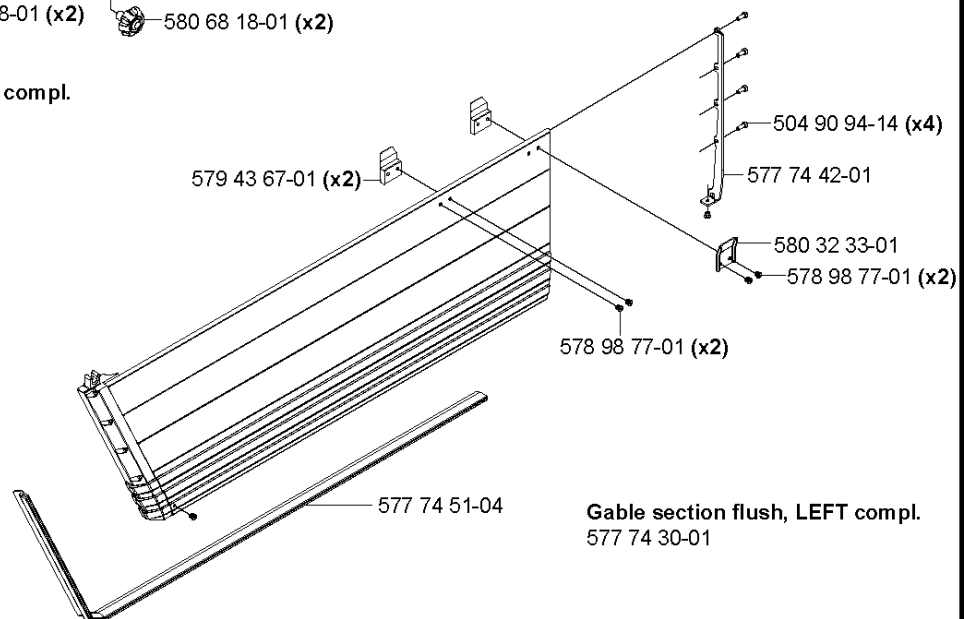

**Gable section flush, LEFT compl.**  
577 74 30-01



Part No	Description	Remark	QTY KIT
504 90 94-14	SCREW ITXSCT		4
531 12 30-63	RAIL		1
541 40 49-09	HANDLE		1
577 48 48-01	HITCH		1
577 48 49-01	HITCH		1
577 48 49-01	HITCH		1
577 61 30-01	LINK		1
577 61 31-01	LINK		1
577 69 92-01	FIXTURE		1
577 69 93-01	FIXTURE		1
577 71 08-01	GUIDE BAR		2
577 74 24-01	BLADE GUARD		1
577 74 30-01	GABLE		1
577 74 32-01	GABLE		1
577 74 42-01	COVER		1
577 74 43-01	COVER		1
577 74 48-01	FRAME		1
577 74 50-01	STRIP		1
577 74 51-04	COVER		1
577 74 52-04	COVER		1
577 90 30-01	BLADE GUARD		1
578 98 77-01	RIVET		6
579 43 67-01	GUIDE PLATE		1
579 56 58-01	SCREW		1
579 56 59-01	SCREW		1
579 56 60-01	SCREW		2
579 56 60-01	SCREW		1
579 56 61-01	SCREW		1
580 32 33-01	GUIDE		1
580 68 18-01	KNOB		1
581 28 51-01	RIVET		4

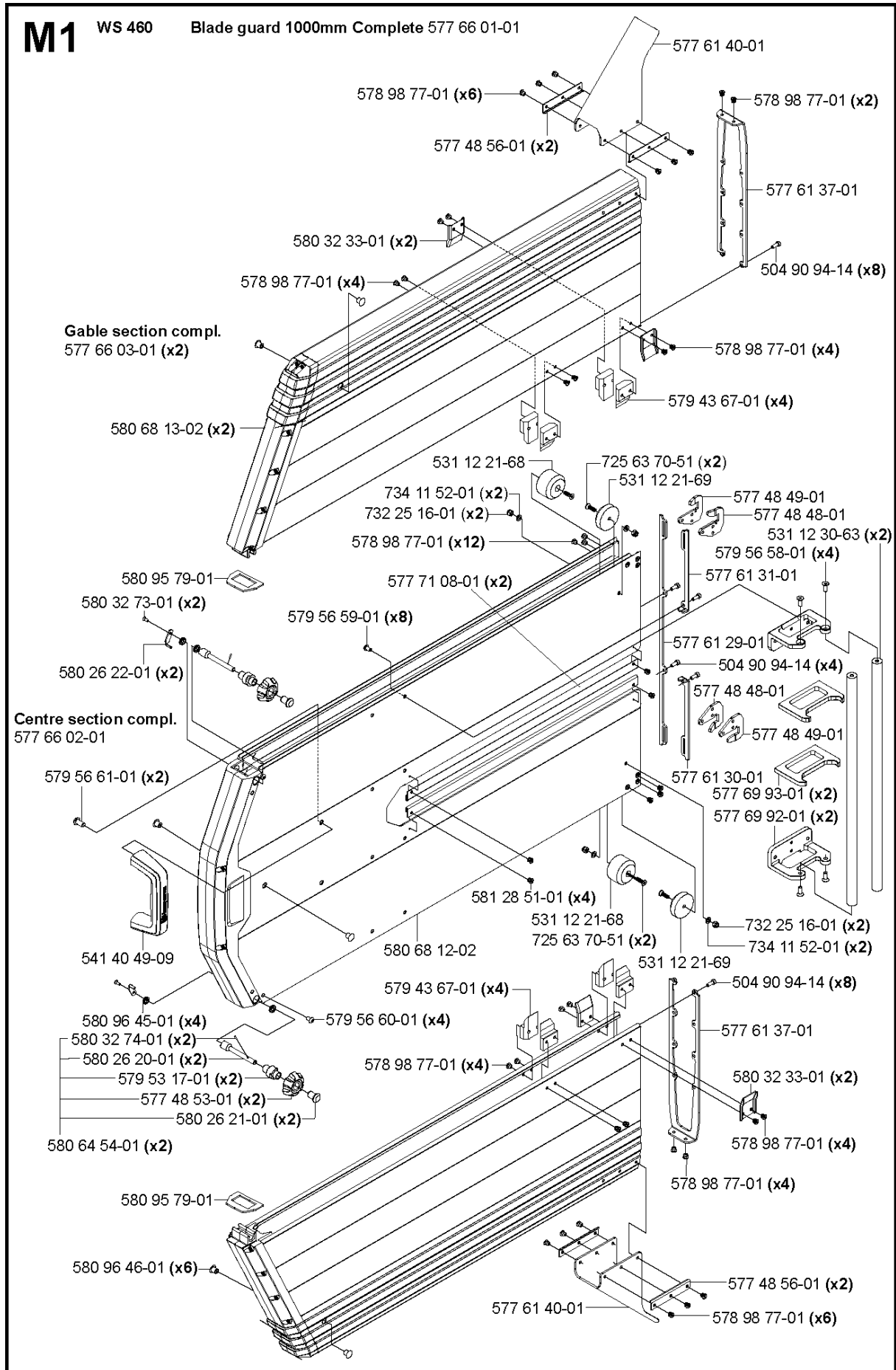

Part No	Description	Remark	QTY KIT
504 90 94-14	SCREW ITXSCT		1
531 12 21-68	GUIDE		1
531 12 21-69	GUIDE		1
531 12 30-63	RAIL		2
541 40 49-09	HANDLE		1
577 48 48-01	HITCH		1
577 48 49-01	HITCH		1
577 48 53-01	KNOB		2
577 48 56-01	WASHER		2
577 61 29-01	LINK		1
577 61 30-01	LINK		1
577 61 31-01	LINK		1
577 61 37-01	END COVER		1
577 61 40-01	SPRAY GUARD		1
577 66 01-01	BLADE GUARD		1
577 66 02-01	BLADE GUARD		1
577 66 03-01	GABLE		2
577 69 92-01	FIXTURE		2
577 69 93-01	FIXTURE		2
577 71 08-01	GUIDE BAR		1
578 98 77-01	RIVET		4
579 43 67-01	GUIDE PLATE		4
579 53 17-01	CONE		2
579 53 17-01	CONE		1
579 56 58-01	SCREW		4
579 56 59-01	SCREW		8
579 56 60-01	SCREW		1
579 56 61-01	SCREW		2
580 26 20-01	SCREW		2
580 26 21-01	NUT		2
580 26 22-01	HOOK		2
580 32 33-01	GUIDE		2
580 32 33-01	GUIDE		1
580 32 73-01	SCREW		2
580 32 74-01	PEN		2
580 64 54-01	KNOB		2
580 68 12-02	GUARD		1
580 68 13-02	GUARD		2
580 95 79-01	GASKET		1
580 96 45-01	V-RING		4
580 96 46-01	RUBBER PLUG		6
581 28 51-01	RIVET		1
725 63 70-51	SCREW IHCSFM		1
732 25 16-01	HEXAGON LOCKING NUT		1
734 11 52-01	WASHER		1

**N2**

WS 460

Blade guard centre section 1200 mm

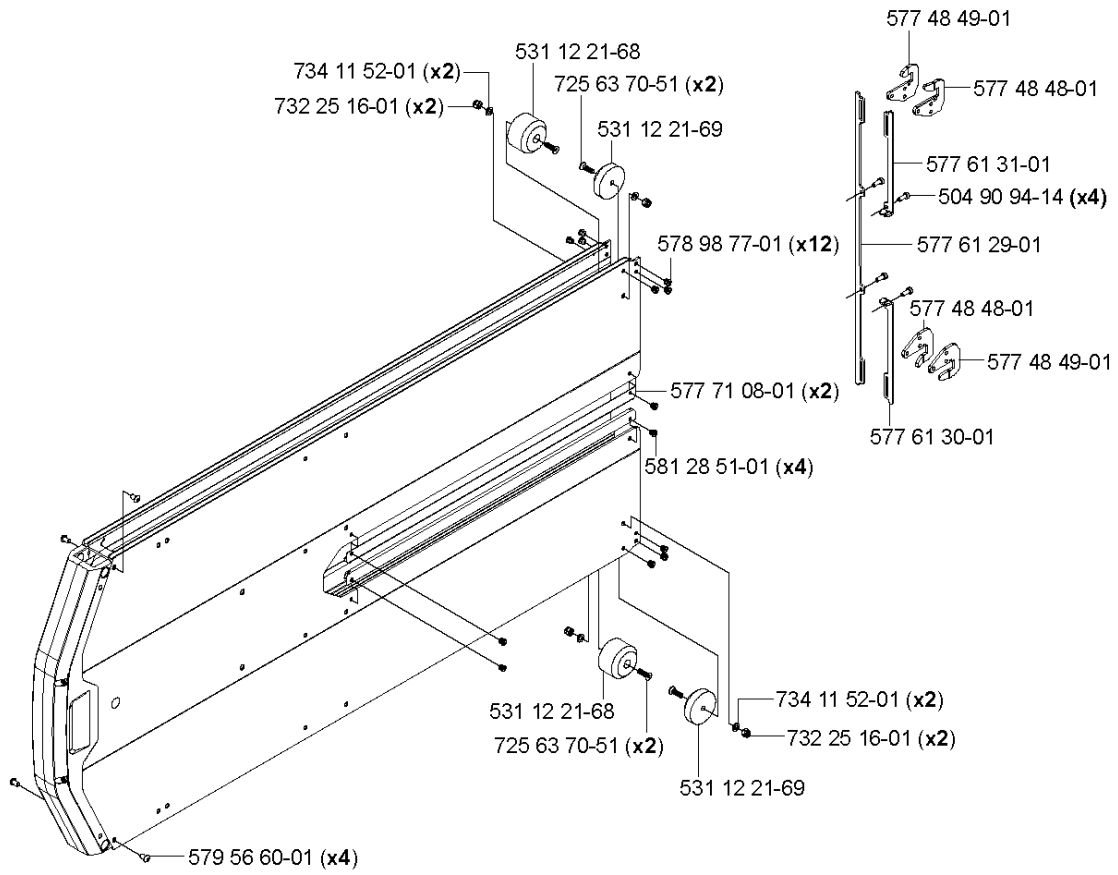

Blade guard gable section 1200 mm

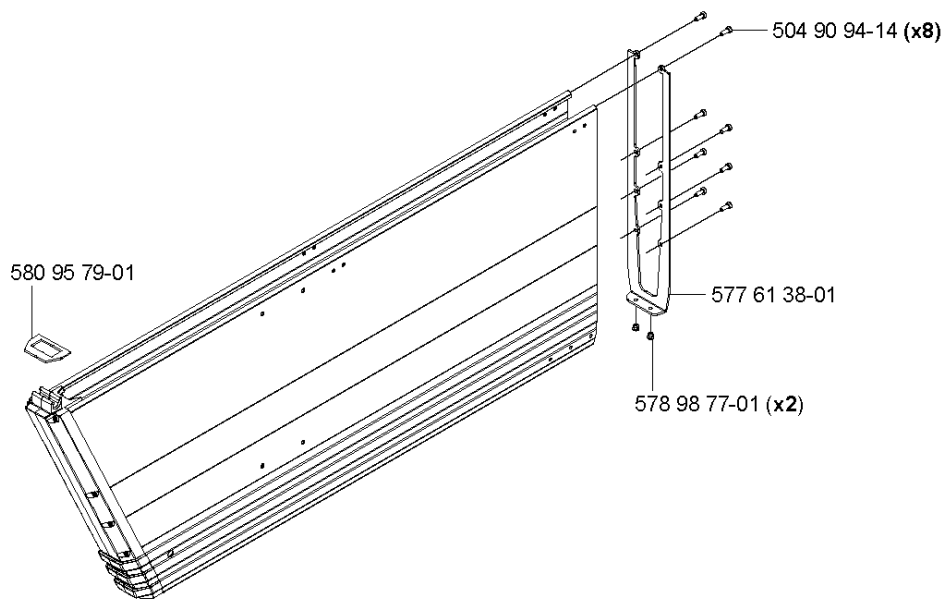

Part No	Description	Remark	QTY KIT
504 90 94-14	SCREW ITXSCT		4
531 12 21-68	GUIDE		2
531 12 21-69	GUIDE		2
577 48 48-01	HITCH		1
577 48 49-01	HITCH		1
577 61 29-01	LINK		1
577 61 30-01	LINK		1
577 61 31-01	LINK		1
577 61 38-01	COVER		1
577 71 08-01	GUIDE BAR		2
578 98 77-01	RIVET		1
579 56 60-01	SCREW		2
580 95 79-01	GASKET		1
581 28 51-01	RIVET		4
725 63 70-51	SCREW IHCSFM		2
732 25 16-01	HEXAGON LOCKING NUT		2
734 11 52-01	WASHER		2

# N3 WS 460 Flush blade guard 1200 mm 577 74 25-01

**Gable section flush, RIGHT compl.**  
577 41 35-01

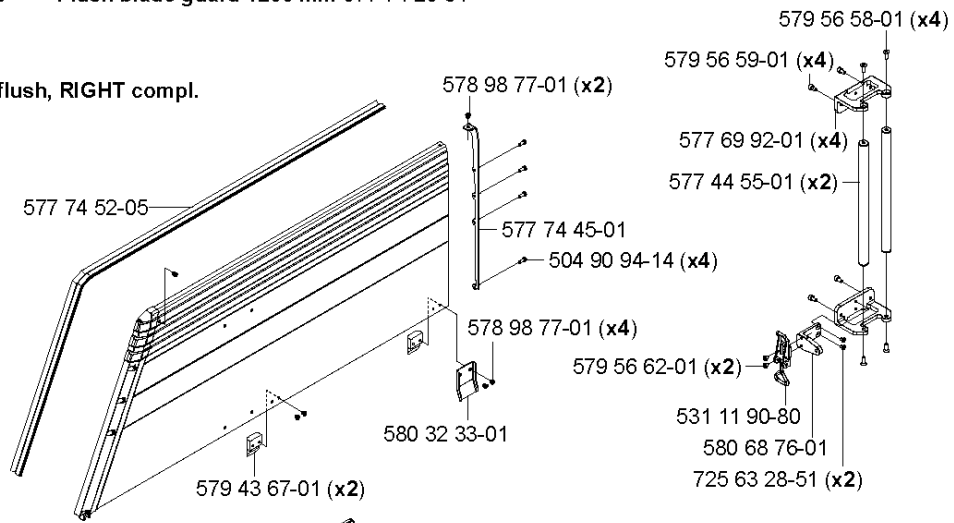

**Centre section flush compl.**  
577 74 33-01

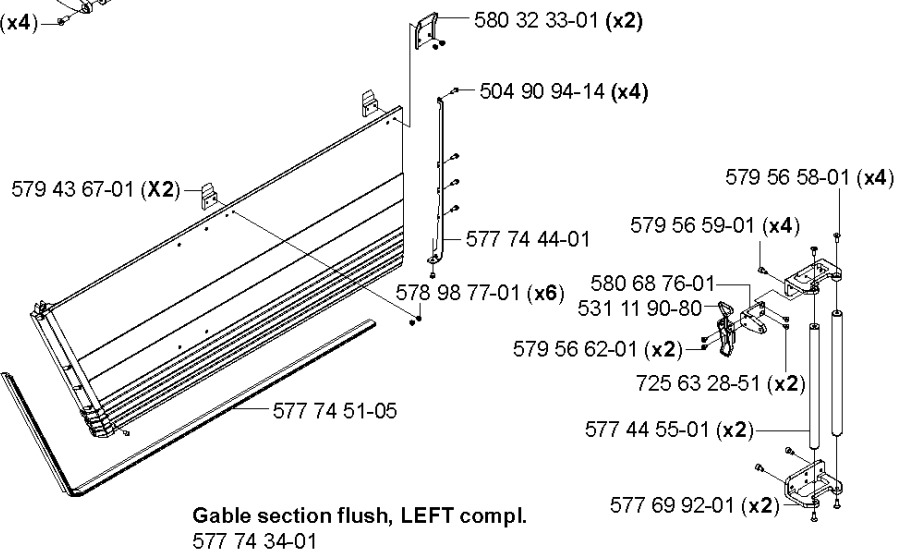
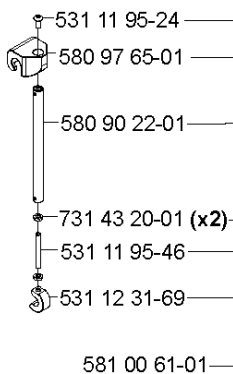
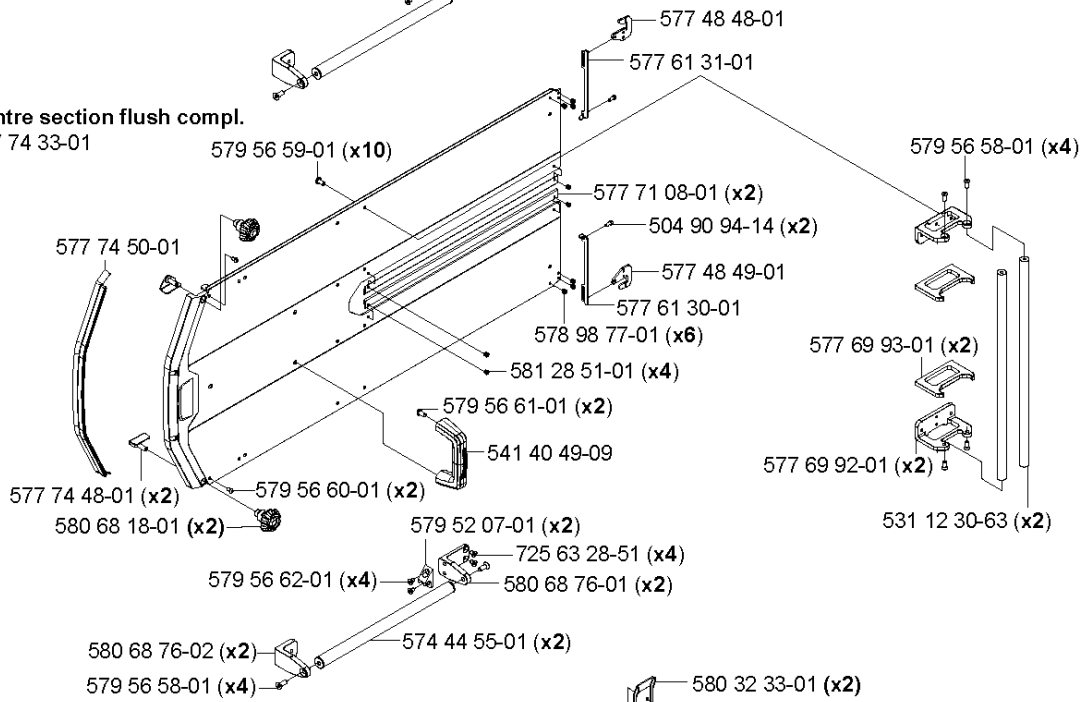

**Gable section flush, LEFT compl.**  
577 74 34-01

Part No	Description	Remark	QTY KIT
504 90 94-14	SCREW ITXSCT		10
531 11 90-80	SNAP LOCKING		1
531 11 95-24	SCREW		1
531 11 95-46	PIN		1
531 12 30-63	RAIL		1
531 12 31-69	CLAMP		1
541 40 49-09	HANDLE		1
574445501	MUFFLER ASSY		2
577 41 35-01	CONTROL		1
577 44 55-01	GUIDE RAIL		1
577 48 48-01	HITCH		1
577 48 49-01	HITCH		1
577 61 30-01	LINK		1
577 61 31-01	LINK		1
577 69 92-01	FIXTURE		1
577 69 93-01	FIXTURE		1
577 71 08-01	GUIDE BAR		1
577 74 25-01	BLADE GUARD		1
577 74 33-01	BLADE GUARD		1
577 74 34-01	GABLE		1
577 74 44-01	COVER		1
577 74 45-01	COVER		1
577 74 48-01	FRAME		1
577 74 50-01	STRIP		1
577 74 51-05	COVER		1
577 74 52-05	COVER		1
578 98 77-01	RIVET		2
578 98 77-01	RIVET		2
579 43 67-01	GUIDE PLATE		1
579 52 07-01	HOOK		1
579 56 58-01	SCREW		1
579 56 59-01	SCREW		4
579 56 60-01	SCREW		1
579 56 61-01	SCREW		1
579 56 62-01	SCREW		1
580 32 33-01	GUIDE		1
580 68 18-01	KNOB		1
580 68 76-01	ANGLE BRACKET		1
580 68 76-02	ANGLE BRACKET		1
580 90 22-01	ARBOR SHAFT		1
580 97 65-01	HOOK		1
581 00 61-01	STRUT		1
581 28 51-01	RIVET		1
725 63 28-51	SCREW IHCSFM		1
731 43 20-01	HEXAGON THIN NUT		1





Part No	Description	Remark	QTY KIT
531 11 90-80	SNAP LOCKING		4
531 11 95-24	SCREW		1
531 11 95-46	PIN		1
531 12 30-63	RAIL		2
531 12 31-69	CLAMP		1
541 40 49-09	HANDLE		1
574445501	MUFFLER ASSY		2
577 44 55-01	GUIDE RAIL		4
577 48 53-01	KNOB		2
577 48 56-01	WASHER		2
577 61 40-01	SPRAY GUARD		1
577 66 04-01	BLADE GUARD		1
577 66 05-01	BLADE GUARD		1
577 66 07-01	GABLE	RIGHT	1
577 66 09-01	GABLE	LEFT	1
577 69 92-01	FIXTURE		4
577 69 93-01	FIXTURE		2
578 98 77-01	RIVET		8
579 43 67-01	GUIDE PLATE		8
579 52 07-01	HOOK		2
579 53 17-01	CONE		2
579 56 58-01	SCREW		4
579 56 59-01	SCREW		4
579 56 61-01	SCREW		2
579 56 62-01	SCREW		4
580 26 20-01	SCREW		2
580 26 21-01	NUT		2
580 26 22-01	HOOK		2
580 32 33-01	GUIDE		2
580 32 73-01	SCREW		2
580 32 74-01	PEN		2
580 64 54-01	KNOB		1
580 68 12-03	GUARD		1
580 68 13-03	GUARD		1
580 68 13-04	GUARD		1
580 68 76-01	ANGLE BRACKET		4
580 68 76-02	ANGLE BRACKET		2
580 90 22-01	ARBOR SHAFT		1
580 96 45-01	V-RING		4
580 96 46-01	RUBBER PLUG		6
580 97 65-01	HOOK		1
581 00 61-01	STRUT		1
725 63 28-51	SCREW IHCSFM		8
731 43 20-01	HEXAGON THIN NUT		2

**L2** WS 460 Flush blade guard 800mm complete 577 74 23-01

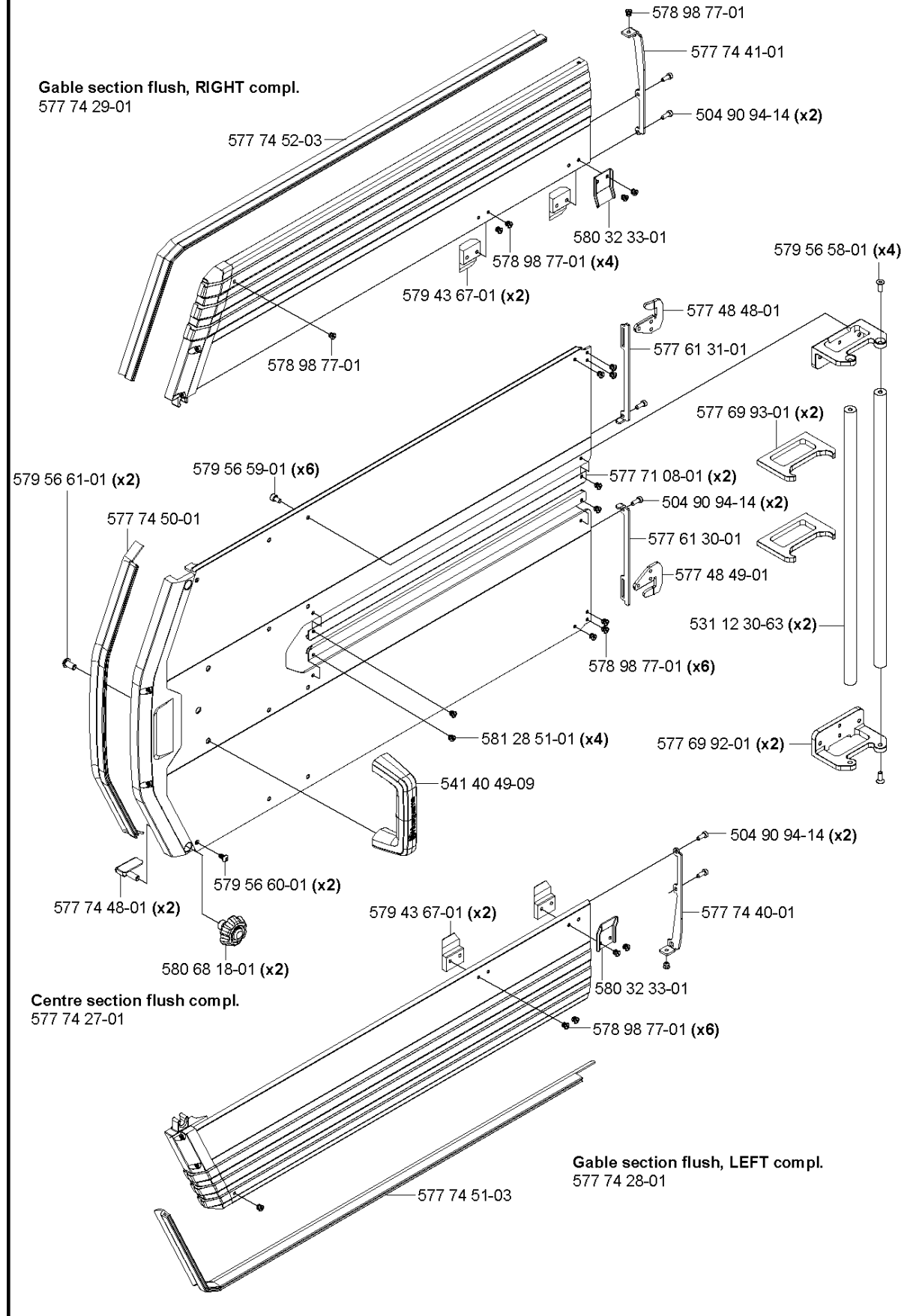

Part No	Description	Remark	QTY KIT
504 90 94-14	SCREW ITXSCT		2
531 12 30-63	RAIL		1
541 40 49-09	HANDLE		1
577 48 48-01	HITCH		1
577 48 49-01	HITCH		1
577 48 49-01	HITCH		1
577 61 29-01	LINK		1
577 61 30-01	LINK		1
577 61 31-01	LINK		1
577 69 92-01	FIXTURE		1
577 69 93-01	FIXTURE		1
577 71 08-01	GUIDE BAR		2
577 74 23-01	BLADE GUARD		1
577 74 27-01	BLADE GUARD		1
577 74 28-01	GABLE		1
577 74 29-01	GABLE		1
577 74 40-01	COVER		1
577 74 41-01	COVER		1
577 74 48-01	FRAME		1
577 74 50-01	STRIP		1
577 74 51-03	COVER		1
577 74 52-03	COVER		1
578 98 77-01	RIVET		6
578 98 77-01	RIVET		1
579 43 67-01	GUIDE PLATE		1
579 56 58-01	SCREW		1
579 56 59-01	SCREW		1
579 56 60-01	SCREW		2
579 56 60-01	SCREW		1
579 56 61-01	SCREW		1
580 32 33-01	GUIDE		1
580 68 18-01	KNOB		1
581 28 51-01	RIVET		4

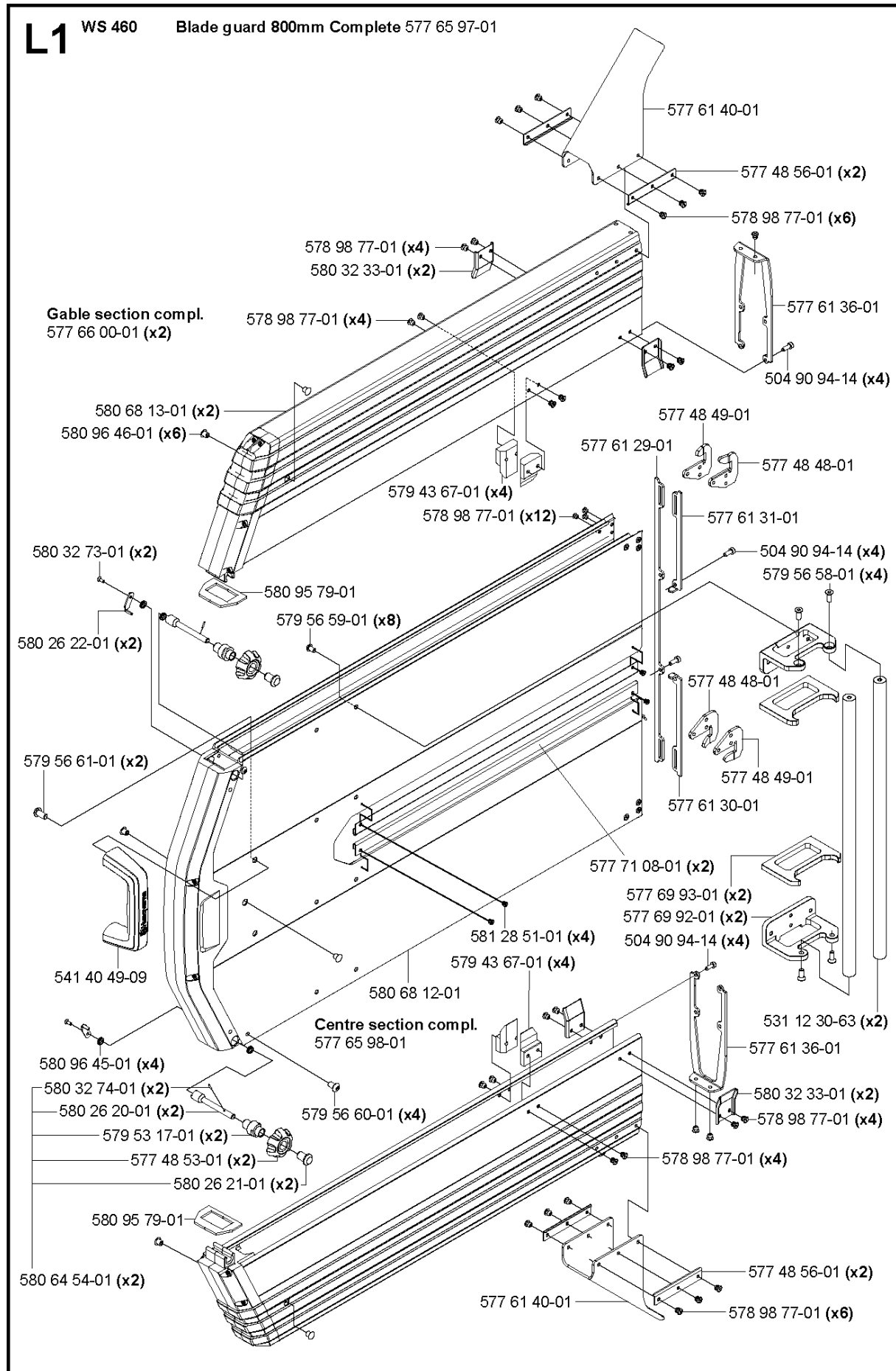

Part No	Description	Remark	QTY KIT
504 90 94-14	SCREW ITXSCT		1
531 12 30-63	RAIL		2
541 40 49-09	HANDLE		1
577 48 48-01	HITCH		1
577 48 49-01	HITCH		1
577 48 53-01	KNOB		2
577 48 56-01	WASHER		2
577 48 56-01	WASHER		1
577 61 29-01	LINK		1
577 61 30-01	LINK		1
577 61 31-01	LINK		1
577 61 36-01	END COVER		1
577 61 40-01	SPRAY GUARD		1
577 65 97-01	BLADE GUARD		1
577 65 98-01	BLADE GUARD		1
577 66 00-01	GABLE		2
577 66 00-01	GABLE		1
577 69 92-01	FIXTURE		2
577 69 93-01	FIXTURE		2
577 71 08-01	GUIDE BAR		1
578 98 77-01	RIVET		2
579 43 67-01	GUIDE PLATE		4
579 43 67-01	GUIDE PLATE		1
579 53 17-01	CONE		2
579 56 58-01	SCREW		4
579 56 58-01	SCREW		4
579 56 59-01	SCREW		8
579 56 60-01	SCREW		1
579 56 61-01	SCREW		2
580 26 20-01	SCREW		2
580 26 21-01	NUT		2
580 26 22-01	HOOK		2
580 32 33-01	GUIDE		2
580 32 73-01	SCREW		2
580 32 74-01	PEN		2
580 64 54-01	KNOB		2
580 64 54-01	KNOB		1
580 68 12-01	GUIDE BAR		1
580 68 13-01	GUARD		2
580 95 79-01	GASKET		1
580 96 45-01	V-RING		4
580 96 46-01	RUBBER PLUG		6
581 28 51-01	RIVET		1

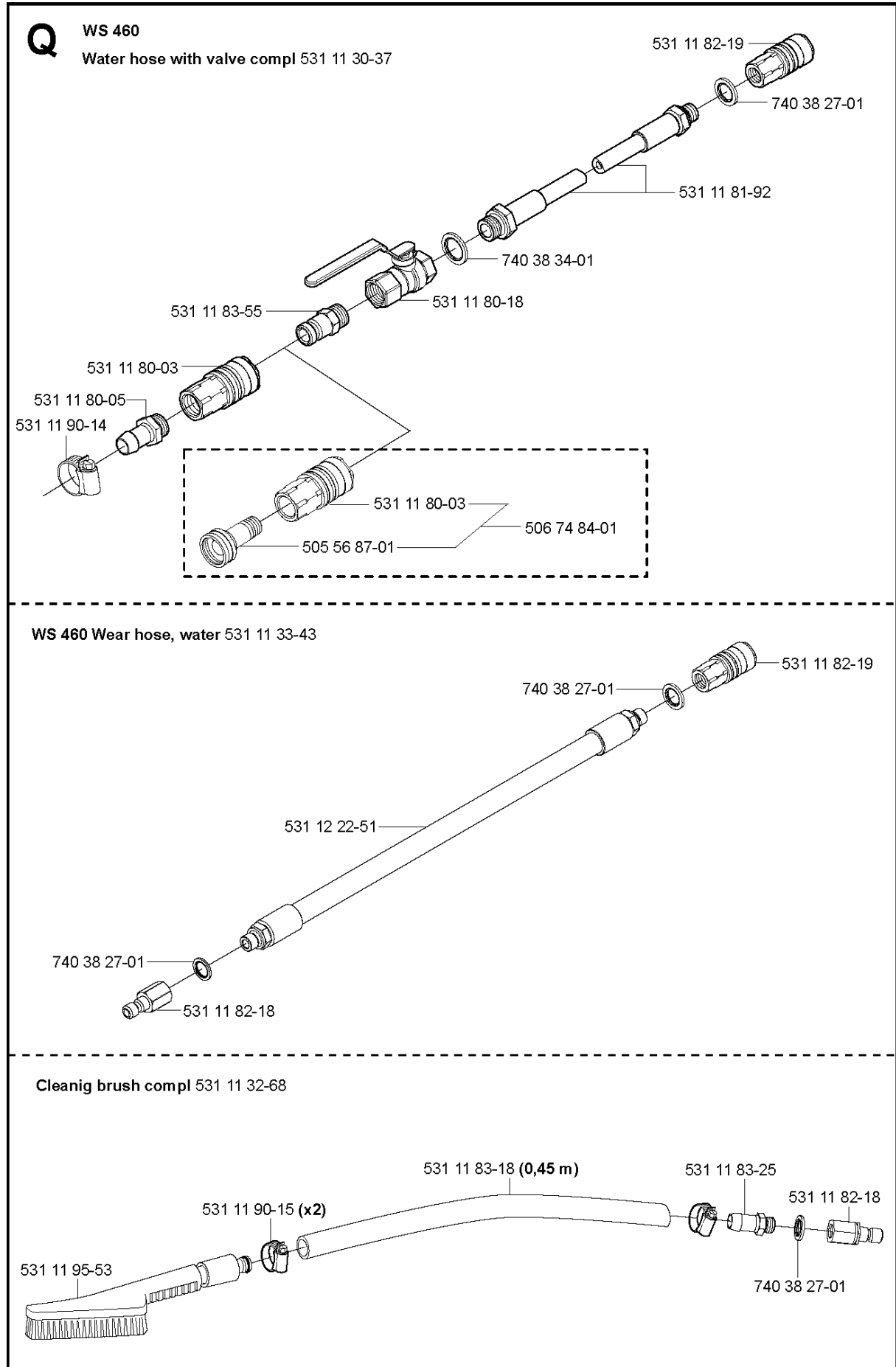

## HOSE

WS460, 2012-07

Part No	Description	Remark	QTY KIT
505 56 87-01	CONNECTION		1
506 74 84-01	ADAPTER		1
531 11 30-37	HOSE		1
531 11 32-68	BRUSH		1
531 11 33-43	WEAR HOSE. WATER COMPLETE		1
531 11 80-03	COUPLING		1
531 11 80-05	NIPPLE		1
531 11 80-18	VALVE		1
531 11 81-92	HOSE		1
531 11 82-18	QUICK COUPLING		1
531 11 82-19	QUICK COUPLING		1
531 11 83-18	HOSE KIT		1
531 11 83-25	NIPPLE		1
531 11 83-55	NIPPLE		1
531 11 90-14	CLAMP		1
531 11 90-15	CLAMP		2
531 11 95-53	BRUSH		1
531 12 22-51	HOSE KIT		1
740 38 27-01	SEALING WASHER		1
740 38 34-01	SEALING WASHER		1

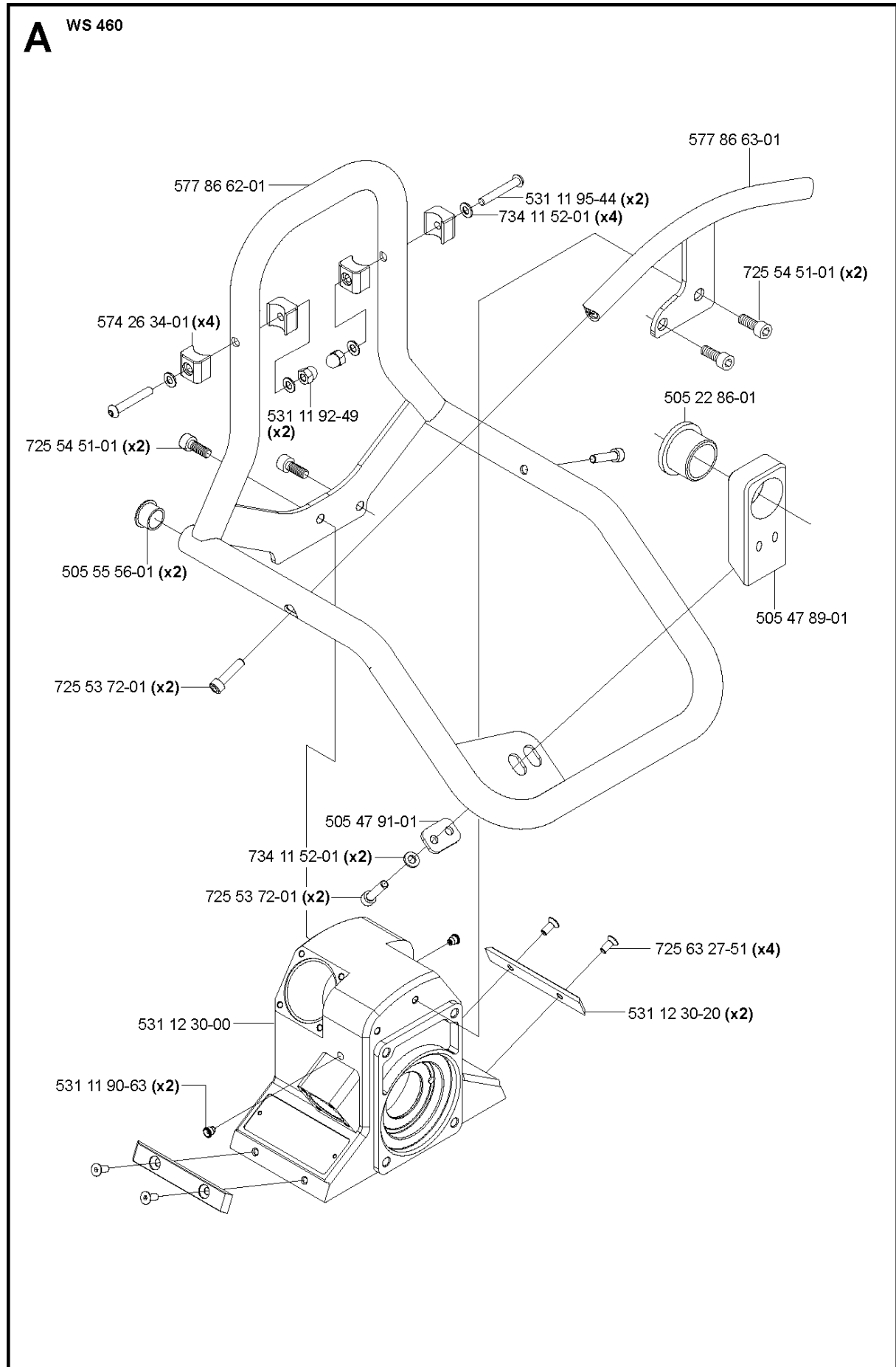



## HOUSING

WS460, 2012-07

Part No	Description	Remark	QTY KIT
505 22 86-01	BUSHING		1
505 47 89-01	HOLDER		1
505 47 91-01	PLATE		1
505 55 56-01	PLUG		2
531 11 90-63	NIPPLE		2
531 11 92-49	CAP NUT		2
531 11 95-44	SCREW		2
531 12 30-00	GEHAEUSE SAEGERKOERPER		1
531 12 30-20	PLATE		2
574 26 34-01	BLOCK		4
577 86 62-01	HANDLE		1
577 86 63-01	CROSSBAR		1
725 53 72-01	SCREW IHSCM		2
725 54 51-01	SCREW IHSCM		2
725 63 27-51	SCREW IHCSFM		2
734 11 52-01	WASHER		2

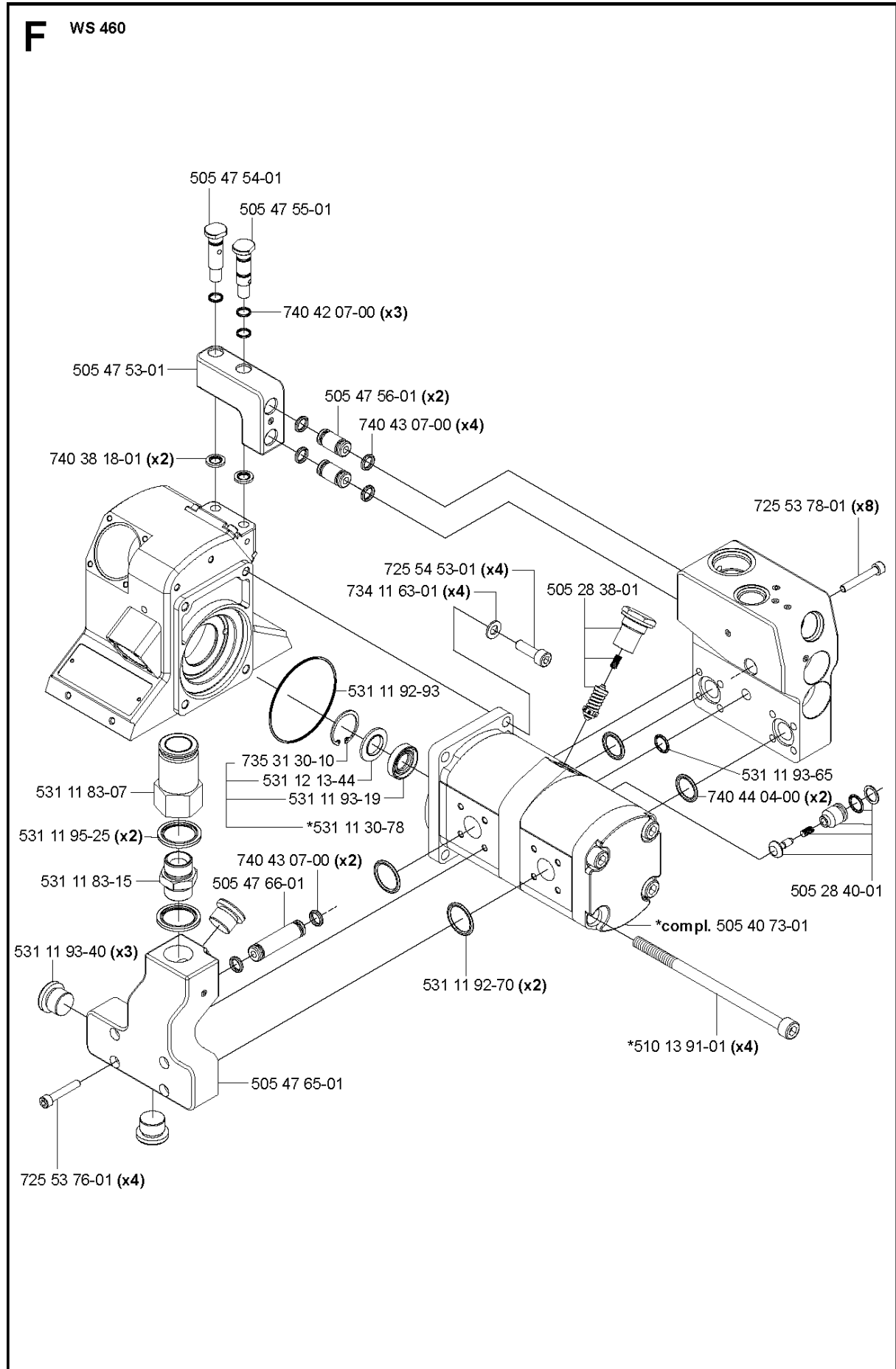

## HYDRAULIC PUMP - MOTOR

WS460, 2012-07

Part No	Description	Remark	QTY KIT
505 28 38-01	VALVE ASSY		1
505 28 40-01	VALVE ASSY		1
505 40 73-01	HYDRAULIC MOTOR		1
505 47 53-01	BLOCK		1
505 47 54-01	SCREW		1
505 47 55-01	SCREW		1
505 47 56-01	OIL PIPE		3
505 47 65-01	BLOCK		1
505 47 66-01	OIL PIPE		1
510 13 91-01	SCREW		4
531 11 30-78	RADIAL SEAL		1
531 11 83-07	COUPLING		2
531 11 83-15	NIPPLE		1
531 11 92-70	O-RING		2
531 11 92-93	O-RING		1
531 11 93-19	SEALING		1
531 11 93-40	PLUG		3
531 11 93-65	O-RING		1
531 11 95-25	SEALING RING		2
531 12 13-44	WASHER		1
725 53 76-01	SCREW IHSCM		1
725 53 78-01	SCREW IHSCM		8
725 54 53-01	SCREW IHSCM		4
734 11 63-01	WASHER		1
735 31 30-10	CIRCLIP		1
740 38 18-01	SEALING WASHER		2
740 42 07-00	O-RING		3
740 43 07-00	O-RING		4
740 44 04-00	O-RING		1

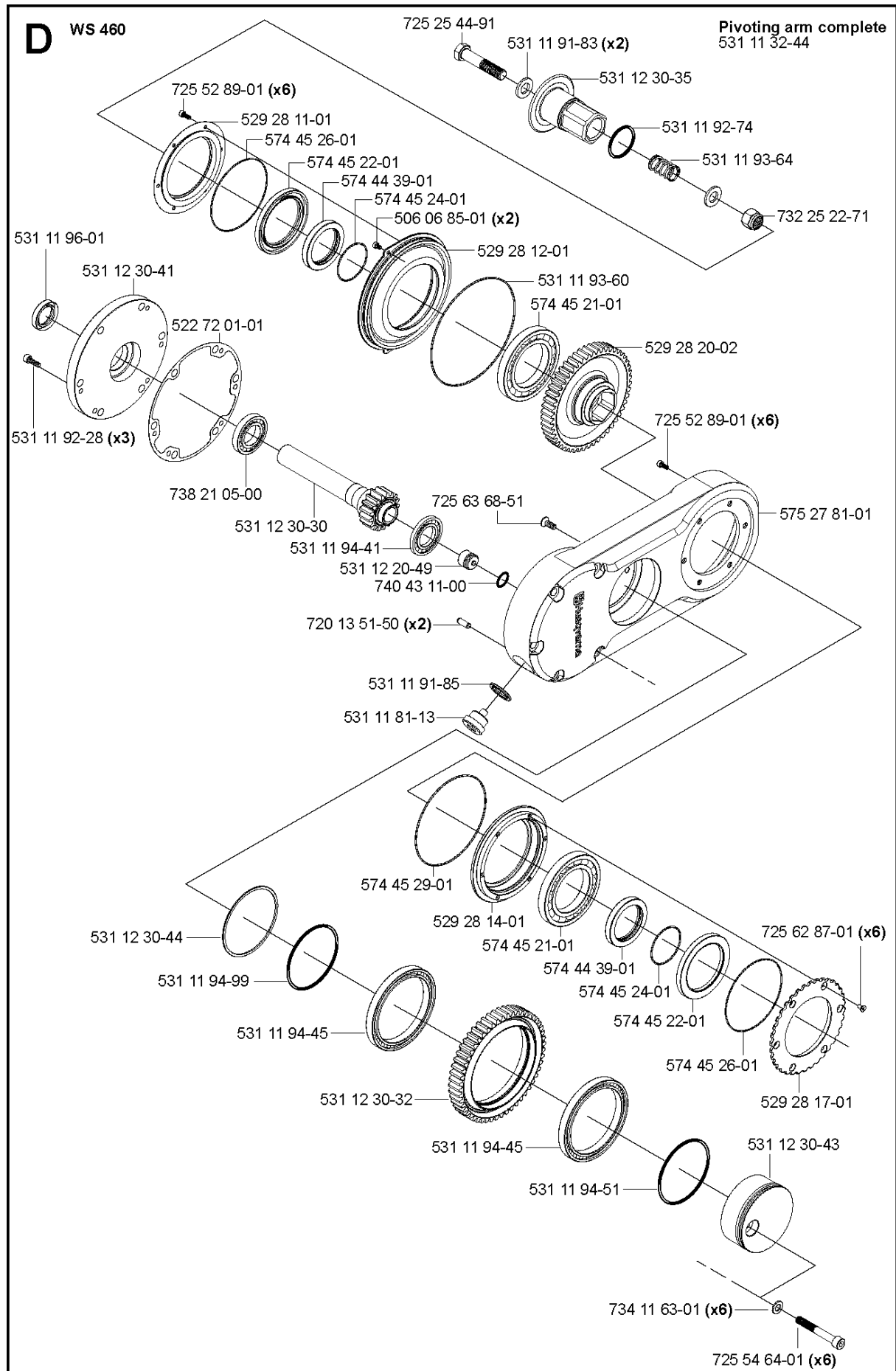

## PIVOTING ARM

WS460, 2012-07

Ref	Part No	Description	Remark	QTY KIT
506 06 85-01	506 06 85-01	SCREW		2
522 72 01-01	522 72 01-01	GASKET		1
529 28 11-01	529 28 11-01	REAR COVER		1
529 28 12-01	529 28 12-01	BEARING COVER		1
529 28 14-01	529 28 14-01	BEARING CAGE		1
529 28 17-01	529 28 17-01	LID		1
531 11 32-44	531 11 32-44	ARM		1
531 11 81-13	531 11 81-13	PLUG		1
531 11 91-83	531 11 91-83	WASHER		2
531 11 91-85	531 11 91-85	SEALING RING		1
531 11 92-28	531 11 92-28	SCREW		3
531 11 92-74	531 11 92-74	O-RING		1
531 11 93-60	531 11 93-60	O-RING		1
531 11 93-64	531 11 93-64	SPRING		1
531 11 94-41	531 11 94-41	BEARING		1
531 11 94-45	531 11 94-45	BEARING		1
531 11 94-51	531 11 94-51	O-RING		1
531 11 94-99	531 11 94-99	O-RING		1
531 11 96-01	531 11 96-01	SEALING		1
531 12 20-49	531 12 20-49	SEALING PLUG		1
531 12 30-30	531 12 30-30	SHAFT		1
531 12 30-32	531 12 30-32	GEAR WHEEL		1
531 12 30-35	531 12 30-35	SHAFT		1
531 12 30-41	531 12 30-41	PLATE		1
531 12 30-43	531 12 30-43	AXLE		1
531 12 30-44	531 12 30-44	SPACER RING		1
574 44 39-01	574 44 39-01	RING		1
574 45 21-01	574 45 21-01	BEARING		1
574 45 22-01	574 45 22-01	SEAL		1
574 45 24-01	574 45 24-01	O-RING		1
574 45 26-01	574 45 26-01	O-RING		1
574 45 29-01	574 45 29-01	O-RING		1
720 13 51-50	720 13 51-50	PARALLEL PIN		2
725 25 44-91	725 25 44-91	SCREW EHHM		1
725 52 89-01	725 52 89-01	SCREW IHSCM		6
725 54 64-01	725 54 64-01	SCREW IHSCM		6
725 62 87-01	725 62 87-01	SCREW IHCSFM		6
725 63 68-51	579 56 58-01	SCREW		1
732 25 22-71	732 25 22-71	HEXAGON LOCKING NUT		1
734 11 63-01	734 11 63-01	WASHER		6
738 21 05-00	738 21 05-00	BALL BEARING		1
740 43 11-00	740 43 11-00	O-RING		1
575 27 81-01	575 27 81-01	GEAR HOUSING		1
529 28 20-02	529 28 20-01	GEAR WHEEL		1

**H** WS 460 Saw carriage 400 complete 505 22 69-03

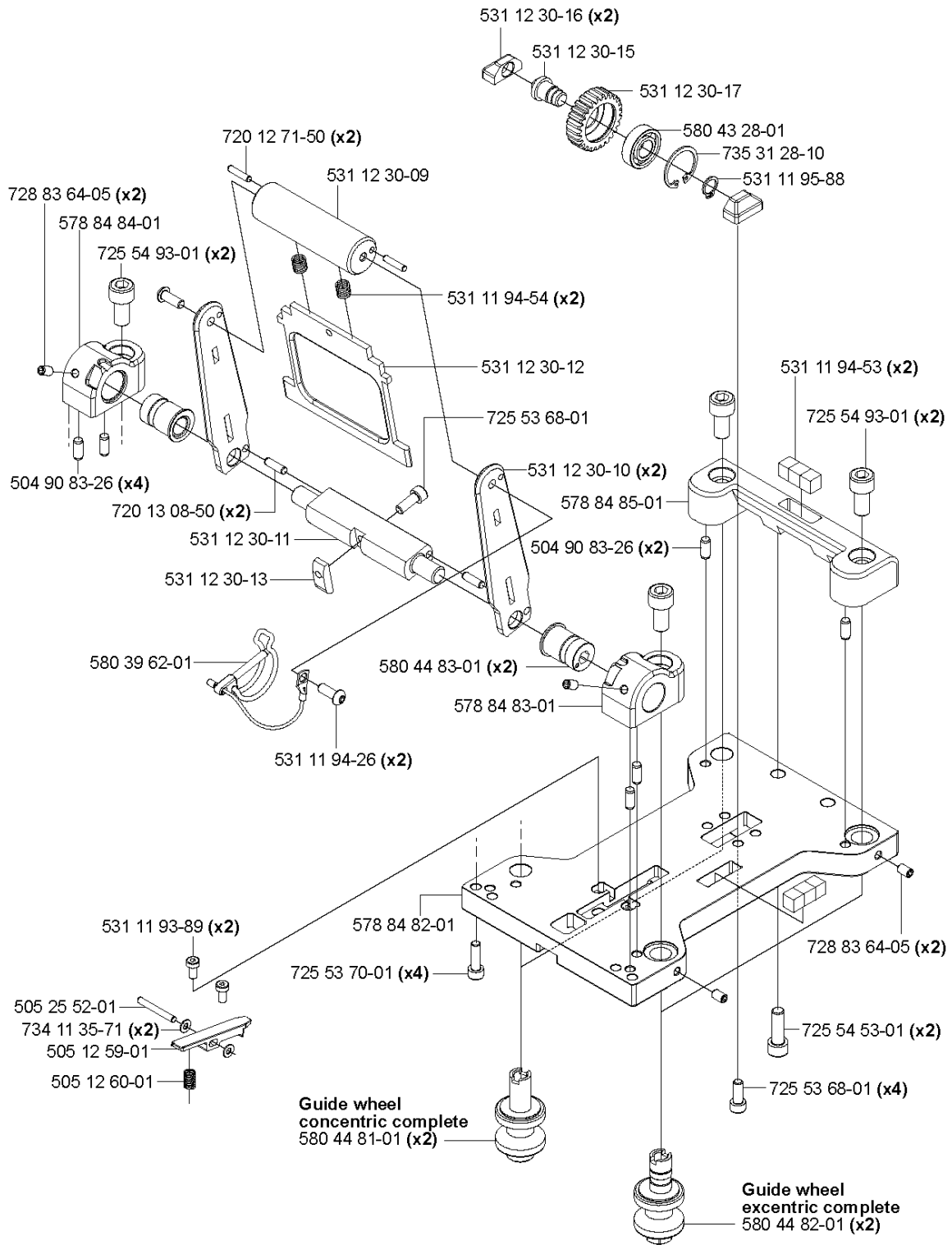

## SAW CARRIAGE

WS460, 2012-07

Part No	Description	Remark	QTY KIT
504 90 83-26	PIN		4
505 12 59-01	ROCKER LEVER		1
505 12 60-01	SPRING		1
505 22 69-03	CARRIAGE		1
505 25 52-01	PARALLEL PIN		1
531 11 93-89	SCREW		1
531 11 94-26	SCREW		2
531 11 94-53	BLOCK		2
531 11 94-54	SPRING		2
531 11 95-88	CLIP		1
531 12 30-09	HANDLE		1
531 12 30-10	BAR		2
531 12 30-11	SHAFT		1
531 12 30-12	HANDLE		1
531 12 30-13	COTTER		1
531 12 30-15	AUTOMATIC FEEDING SYSTEM		1
531 12 30-16	SHAFT		2
531 12 30-17	GEAR WHEEL		1
578 84 82-01	PLATE		1
578 84 83-01	HOLDER		1
578 84 84-01	HOLDER		1
578 84 85-01	SOCKET		1
580 39 62-01	LOCKING PIN		1
580 43 28-01	BEARING		1
580 44 81-01	WHEEL		1
580 44 82-01	WHEEL		2
580 44 83-01	SLEEVE		2
720 12 71-50	PARALLEL PIN		2
720 13 08-50	PARALLEL PIN		2
725 53 68-01	SCREW IHSCM		4
725 53 70-01	SCREW IHSCM		1
725 54 53-01	SCREW IHSCM		2
725 54 93-01	SCREW IHSCM		2
728 83 64-05	SCREW IHSETM		2
734 11 35-71	WASHER		1
735 31 28-10	CIRCLIP		1

**P** WS 460  
Toolkit compl 501 37 52-01

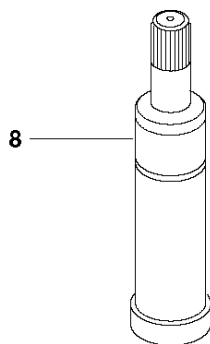
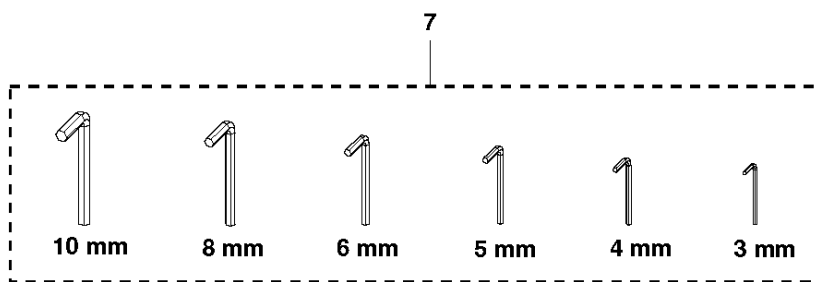
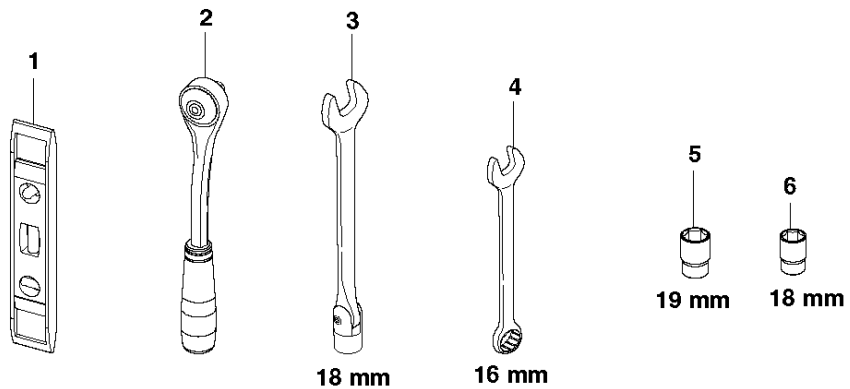



## TOOLS

WS460, 2012-07

Ref	Part No	Description	Remark	QTY KIT
1	531 11 95-31	TOOL		1
2	531 11 95-32	TOOL		1
3	531 11 90-65	WRENCH		1
4	531 11 95-33	TOOL		1
5	531 11 95-41	SOCKET		1
6	531 11 95-34	SERVICE TOOLS		1
7	525 45 52-01	HEX KEY		1
8	531 11 91-08	GREASE GUN		1

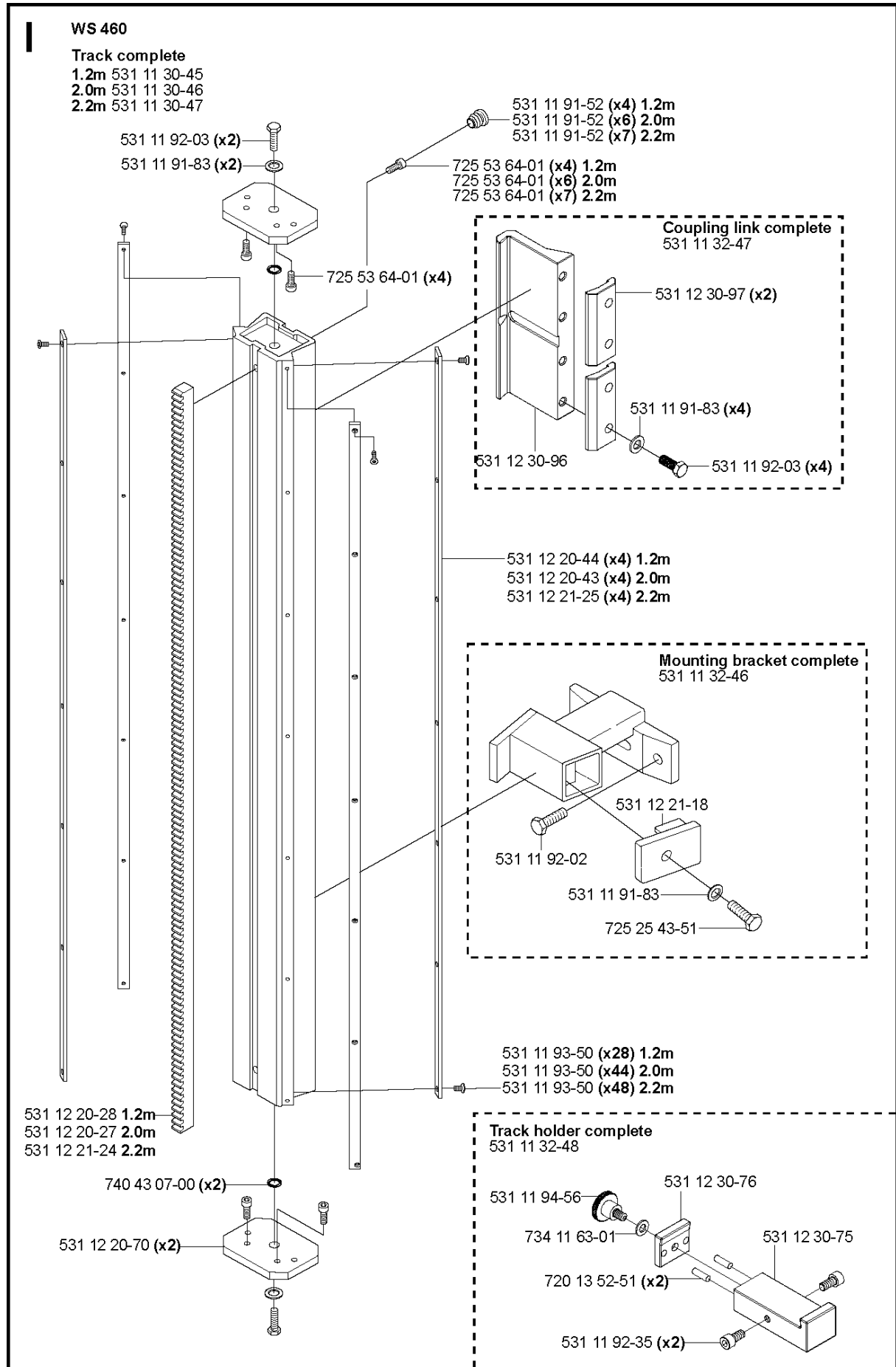

## TRACK SYSTEM

WS460, 2012-07

Part No	Description	Remark	QTY KIT
531 11 30-45	TRACK		1
531 11 30-46	TRACK		1
531 11 30-47	TRACK		1
531 11 32-46	BRACKET		1
531 11 32-47	COUPLING		1
531 11 32-48	HOLDER ASSY		1
531 11 91-52	RUBBER PLUG	2.0m	6
531 11 91-83	WASHER		4
531 11 92-02	SCREW		1
531 11 92-03	SCREW		4
531 11 92-35	SCREW		2
531 11 93-50	SCREW		1
531 11 94-56	SCREW		1
531 12 20-27	GEAR		1
531 12 20-28	GEAR		1
531 12 20-43	GUIDE RAIL	2.0m	4
531 12 20-44	GUIDE	1.2m	1
531 12 20-70	PLATE		2
531 12 21-18	WASHER		1
531 12 21-24	GEAR		1
531 12 21-25	GUIDE	2.2m	4
531 12 30-75	BRACKET		1
531 12 30-76	PLATE		1
531 12 30-96	COUPLING		1
531 12 30-97	PLATE		2
720 13 52-51	PARALLEL PIN		2
725 25 43-51	SCREW EHHM		1
725 53 64-01	SCREW IHSCM		4
734 11 63-01	WASHER		1
740 43 07-00	O-RING		2