

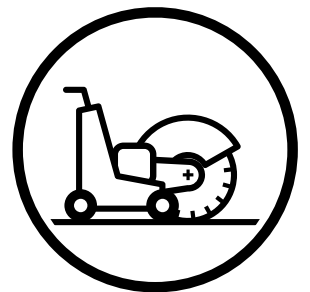

Operator's manual
FS 627



Please read the operator's manual carefully and make sure you understand the instructions before using the machine.

English



WARNING!

DO NOT ATTEMPT TO OFF LOAD ANY PIECE OF EQUIPMENT ON UNEVEN GROUND OF ANY DEGREE OF SLOPE. DO NOT LEAVE EQUIPMENT UNATTENDED ON UNEVEN GROUND. INJURY OR DEATH MAY OCCUR.

THIS EQUIPMENT SHOULD NOT BE OPERATED BY ANYONE UNDER THE AGE OF 18.

DO NOT JUMP START A DEAD BATTERY ON THE UNIT. THE PROCESS OF JUMP STARTING A DISCHARGED BATTERY CAN, UNDER CERTAIN CONDITIONS, RESULT IN BATTERY EXPLOSION FROM IGNITION OF HYDROGEN GAS, RESULTING IN INJURY.

WARNING!

- IF THIS PRODUCT IS USED IMPROPERLY, SERIOUS INJURY OCCUR.
- DO NOT USE LOOSE CLOTHES AS IT CAN BE COME ENTANGLED IN THE MACHINERY.
- KEEP CLEAR OF ALL MOVING PARTS WHILE MACHINE RUNNING.
- NEVER WORK UNDER THE MACHINE IF RUNNING OR NOT PROPERLY SECURED.
- WEAR SAFETY GLASSES.
- WEAR GLOVES.
- WEAR GEAR PLUGS.
- WEAR STEEL TOE SHOES.

- ALWAYS USE THE PROPER CUTTING R.P.M. AS SPECIFIED BY THE BLADE MANUFACTURER.
- ALWAYS SHUT OFF THE MACHINE BEFORE CHANGING BLADES. (UNPLUG ELECTRIC VERSION)
- INSURE PROPER POSITION AND SECUTIRY OF SAFETY GUARDS BEFORE OPERATING THE MACHINE.
- INSPECT MACHINE BEFORE USE FOR SAFE OPERATION.
- FIRE HAZZARD! INSPECT MACHINE FOR LEAKING OIL OR GAS BEFORE OPERATION.

- 1.— THIS MANUAL PROVIDES THE BASIC INSTRUCTIONS FOR THE OPERATION AND MAINTENANCE OF THE **FS 627 CONCRETE SAW**.
AN ENGINE MANUAL IS ALSO PROVIDED WITH EACH MACHINE.

2.—

FS 627

ENGINE.	CH 742 KOHLER "/25hp"
DRIVE UNIT.	HYDROSTATIC TRANSMISSION FORWARD & REVERSE—RAISE & LOWER MECH. SPEEDS FROM 0 TO 200 FT PER MINUTE
SPINDLE.	1 7/16 WITH TAPERED ROLLER BEARINGS
ARBOR SIZE.	1" WITH 1/4 SQ. KEYS
BLADE CAPACITY.	14' TO 30" DIAMETER
DEPTH CONTROL.	HYDRAULIC RAISE & LOWER
BLADEGUARD.	18" STANDARD
FUEL CAPACITY.	5.25 GALLONS
WEIGHT.	700 LBS.
LENGHT.	43"
WIDTH.	29"
HEIGHT.	44"

OPTIONAL EQUIPMENT.

- 1.— NIGHT LIGHT.
- 2.— BLADE GUARDS. 24" 30"
- 3.— BLADE SAFETY SWITCH.
- 4.— DEEP CUTTING SHEAVE OPTIONS.
- 5.— PROPANE.

- 3.— THE NEW MACHINE WAS TEST—RUN BEFORE LEAVINGHUSQVARNA CONSTRUCTION PRODUCTS. HOWEVER, THE ENGINE SHOULD BE CHECKED WITH THE ENGINE MANUAL SO THAT THE CORRECT ROUTINE IS FOLLOWED ALL THE TIME. THIS IS VERY IMPORTANT DURING THE INITIAL RUNNING—IN OF THE ENGINE.

4.— LUBRICATION CHART

ITEM	CHECK	LUBRICANT
TRANSMISSION REAR AXLE AIR FILTER	MONTHLY MONTHLY CHECK WEEKLY SERVICE AS REQUIRED	30W ENGINE OIL S.A.E. EP 90
HYDRAULIC PUMP	CHECK MONTHLY	ATF DEXRON
SPINDLE BRNGS REAR AXLE BRNGS PIVOT AXLE	DAILY WEEKLY WEEKLY	GREASE GREASE GREASE

- 5.— WE SUGGEST THAT THE SPINDLE BEARINGS BE CHECKED DAILY FOR THE FIRST WEEK. IF THE BEARINGS ARE TOO HOT TO TOUCH THE REASON IS EITHER INSUFFICIENT LUBRICATION OR DRIVE BELTS ARE TOO TIGHT. TO ADJUST BELTS FOLLOW INSTRUCTIONS ON PAGE 6. IT IS IMPORTANT THAT THE TENSION IS JUST ENOUGH TO DRIVE WITHOUT SLIPPING. TOO TIGHT SHORTENS BEARING LIFE TOO LITTLE TENSION SHORTENS BELT LIFE. THE TRANSMISSION BELT IS SELF— ADJUSTING AS LONG AS THE IDLER LINKEAGE IS FREE AND THE SPRING IS TIGHT. THE BELT TENSION SHOULD BE CHECKED DAILY.

CONTROL OPERATING INSTRUCCIONS

- 1.—WATER SUPPLY: WATER SUPPLY: CONNECT THE WATER SUPPLY TO THE INLET HOSE, OPEN HAND VALVE AND MAKE SURE THAT THE JETS MOUNTED IN THE BLADE COVER ARE FREE OF OBSTRUCTION. THREE TO FIVE GALLONS OF WATER ARE REQUIRED TO COOL THE DIAMOND BLADE ADEQUATELY BLOW OUT WATER LINES IN FREEZING CONDITIONS
- 2.—RAISE& LOWER: BY PUSHING A MOMENTARY SWITCH ACTIVATES AN ELECTRIC OVER HYDRAULIC PUMP TO RAISE THE FRONT OF SAW. TO LOWER SAW, OPEN THE VALVE AND YOU CAN CONTROL LOWERING SPEED BY OPENING THE VALVE GRADUALLY
- 3.—SPEED CONTROL: A SINGLE LEVER DETERMINES FORWARD SPEED AND REVERSE SPEED WITH A NEUTRAL DYNAMIC BRAKE POSITION IN BETWEEN BY PUSHING LEVER FORWARD, THE SAW WILL GO AT VARIOUS SPEEDS. BY PULLING LEVER BACK THE SAW WILL GO BACKWARDS AT VARIOUS SPEEDS.
- 4.— FREEWHEEL: THIS CONTROL IS LOCATED ON TOP OF THE SAW, BY PULLING THE KNOB BY-PASSES FLUID IN HYDROSTATIC TRANSMISSION WHICH ENABLES YOU TO MOVE THE SAW WHEN MOTOR IS NOT RUNNING. (CAUTION: ONLY ACTIVATE FREEWHEEL WHEN ENGINE IS AT IDLE OR OFF) WHEN MOVING THE MACHINE MORE THAN A FEW FEET, START THE ENGINE DRIVE THE UNIT.
- 5.—BLADE FITTING: LIFT OFF THE BLADE, REMOVE THE NUT WITH THE WRENCH PROVIDED RAISE THE SAW ENOUGH TO CLEAR BLADE AND REMOVE THE OUTER HALF OF THE COLLAR INSPECT BOTH SURFACES FOR DIRT OR OTHER IRREGULARITIES AND PLACE THE BLADE ON THE INSIDE COLLAR SO THAT THE HOLE IN THE BLADE SEATS ON THE COLLAR PIN. REPLACE OUTER COLLAR HALF AND NUT USING WRENCH SUPPLIED. TIGHTEN NUT BY STRIKING THE WRENCH HANDLE WITH A HAMMER AND ATTACH BLADEGUARD.
- 6.—STARTING THE ENGINE: THIS SHOULD BE DONE AS STATED IN THE ENGINE MANUAL.
- 7.—POSITIONING THE SAW: THE SAW MAY BE MANUVERED IN SEVERAL WAYS. POSITION THE HANDLES TO SUIT THE OPERATOR AND CONDITIONS. THE DIFFERENTIAL AXLE ALLOWS THE SAW TO BE ROTATED ABOUT THE CENTER OF THE REAR AXLE BY PUSHING THE HANDLES DOWN AND LIFTING THE FRONT WHEELS.THE SAW MUST BE MOVED LIKE WHEELBORROW BY LIFTING THE REAR WHEELS TO MOVE THE SAW MORE THAN A FEW FEET OR UP AND DOWN RAMPS.
- 8.—CUTTING: LAY OUT AREA TO BE CUT WITH A CHALK LINE OR STRING AND PAINT. LEAD MACHINE INTO CUT WITH POINTER DOWN. WHEN POINTER AND BLADE ARE IN LINE WITH LAYOUT, WITH THE WATER ON, LOWER THE BLADE INTO THE CUT (NOTE) WHEN CUTTING CONCRETE IT IS GENERALLY REQUIRED TO MAKE MORE THAN ONE PASS. AFTER SAW THE BLADE REACHES DESIRED DEPTH, MOVE LEVER FORWARD UNTIL SAW REACHES A GOOD CUTTING SPEED. UPON COMPLETION OF CUT RETURN SPEED CONTROL LEVER TO NEUTRAL POSITION. RAISE THE SAW UNTIL BLADE CLEARS PAVING.
- 9.— CLEANING: THE ENTIRE SAW SHOULD BE THOROUGHLY CLEANED IMMEDIATELY AFTER EACH USE. A CAR WASH DOES A GOOD JOB. USE CAUTION TO PREVENT WATER FROM ENTRING GASOLINE TANK OR ELECTRICAL SWITCHES.
- 10.— STORAGE: THE SAW SHOULD BE LUBRICATED AFTER CLEANING.
- 11.— CALIBRATION:THE BLADE SPINDLE AND FRONT AND REAR AXLES MUST BE ALIGNED TO MAKE THE SAW CUT IN A STRAIGHT LINE WITH THE BLADE PARALLEL TO THE DIRECTION OF TRAVEL.
- 12.— REPLACEMENT PARTS: PARTS MUST BE ORDERED FROM MECO. GIVE THE MODEL AND SERIAL NUMBER OF THE SAW.

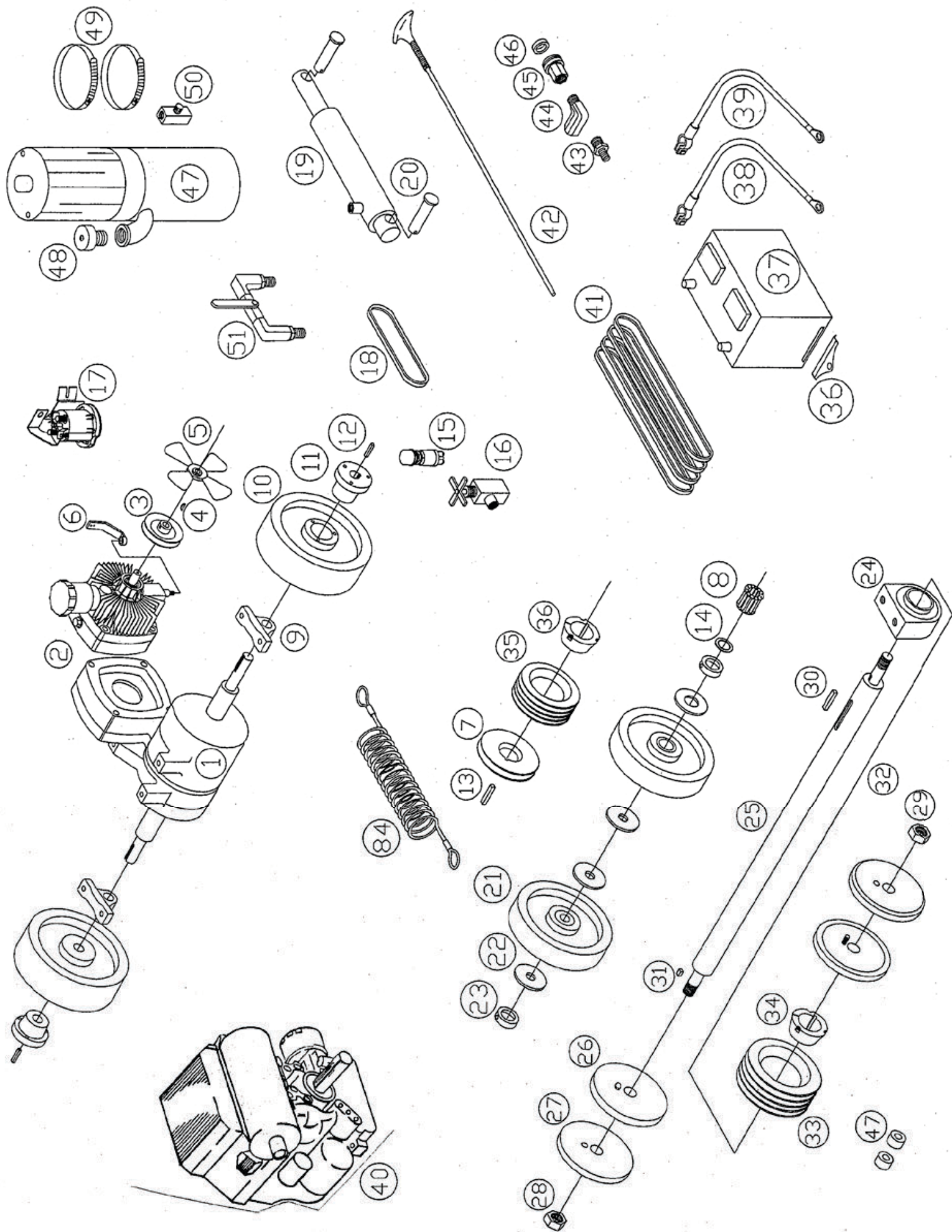

HUSQVARNA FS 627

ITEM	PART #	DESCRIPTION	QTY
1	30108	DIFFERENTIAL, LOCKED	1
2	30109	HYDROSTAT	1
3	30103	PULLEY	1
4	30594	KEY 1/8 X 1/2 WOODRUFF	1
5	30188	FAN	1
6	10591	LEVER, FWD/REV	1
7	10336-1	PULLEY, SINGLE 3 1/2 X 1 7/16	1
8	30270	BEARING, ROLLER	2
9	30263	BEARINGS, 1" PILLOW BLOCK	4
10	30134	WHEEL 10" X 3" X 1"	2
11	33814	BUSHING, S H X 1" Q D	2
12	10334	KEY 1/4 X 3"	2
13	NPN	KEY, 3/8 X 3/8 X 4 1/4	1
14	30269	SEALS	4
15	30241	BUTTON, PUSHING RAISE	1
16	30161	VALVE, LOWERING	1
17	33943	SOLENOID	1
18	31068	BELT, 2580 DRIVE FROM MOTOR TO TRANSMISSION 27 KOHLER	1
19	30128	CYINDER, 1"	
20	30471	PIN, 5/8 X 3"	2
21	30133	WHEELS, 6" X 2" X 1"	2
22	33514	WASHER 1" USS	4
23	30132	1" COLLAR	2
24	30329	1 7/16 PILLOW BLOCK BEARINGS	2
25	30321	SPINDLE	1
26	30135	4" INNER COLLARS	2
27	11411	4" OUTER COLLARS	2
28	30137	1" 14 L.H.T. NUT	1
29	30138	1" 14 R.H.T. NUT	1
30	10575	3/8 X 3/8 X 3 KEY STOCK	1
31	11304	1/4 X 1/4 X 9/16 KEY STOCK	2
32	30335	PULLEY, 3.65 - 4 GROOVE (ON SPINDLE)	1
33	30332	TAPPER LOCK, 1610 1 7/16	1
34	30600	ENGINE PULLEY, 3V 3.35 4 GROOVE (ON MOTOR)	1
35	30332	TAPPER LOCK, 1610 1 7/16	
36	30183	BATTERY HOLD DOWN	1
37	NPN	BATTERY, GROUP 22F	1
38	30168	CABLE, EYE-TERM BATTERY POSITIVE	1
39	30604	CABLE, EYE-TERM BATTERY NEGATIVE	1
40	40743	ENGINE, CH 742	1
41	30287	BELTS, 3VX 400	4
42	30240	CABLE, NEUTRAL	1
43	30537	BARB, 1/2 NPT X 1/2 FITTING	1
44	30527	ELBOW, 1/2 NPT STREET	1
45	31032	HOSE CONNECTOR 3/4 GARDEN HOSE X 1/2 NPT	1
46	30610	HOSE, GARDEN WASHER	1
47	30156	PUMP, HYDRAULIC	1
48	30577	BREATHER, PUMP	1
49	30595	CLAMP, 5" WORM DRIVE	2
50	30157	1/4 NEEDLE VALVE	1
51	20623	VALVE, WATER ASSEMBLY	1

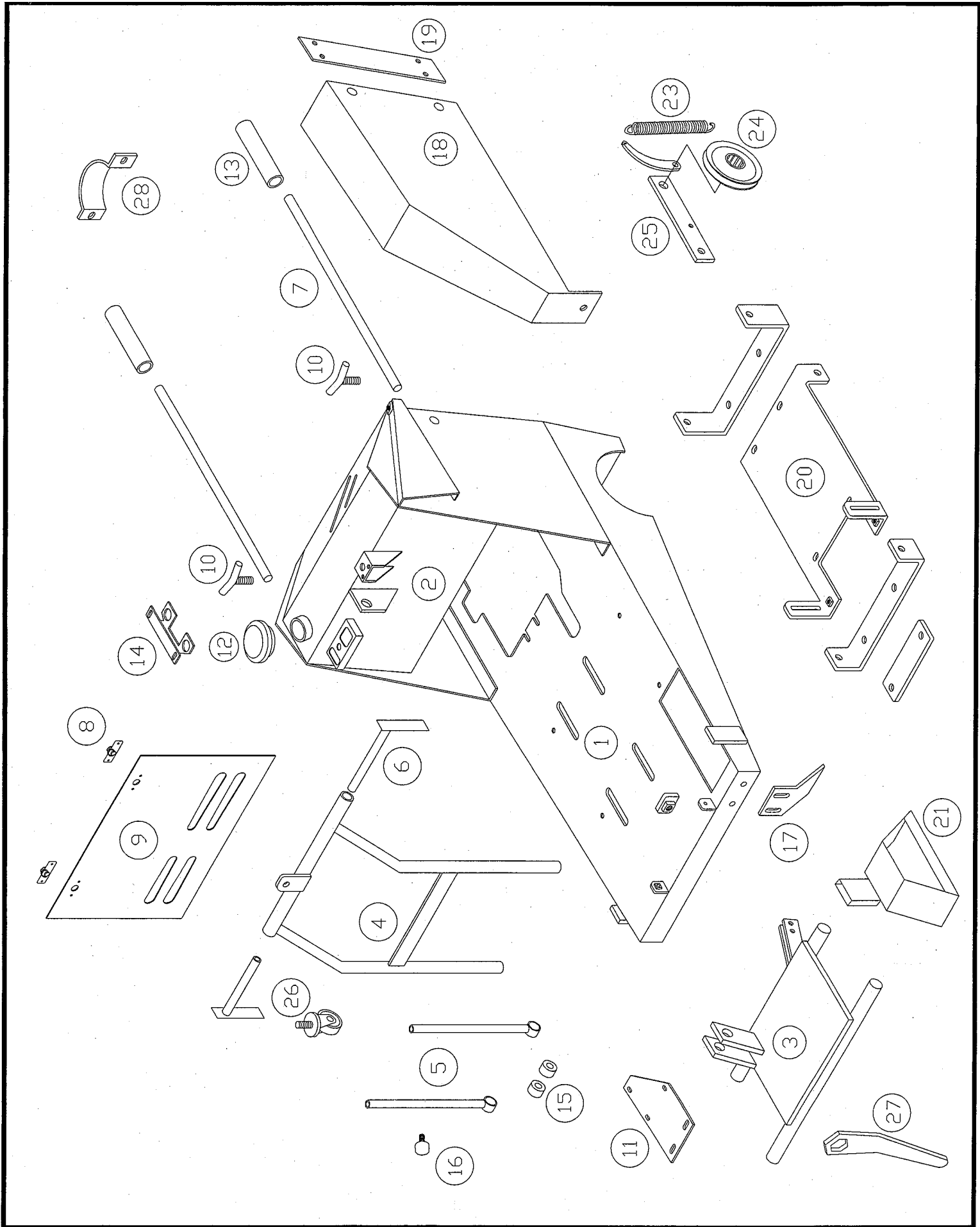

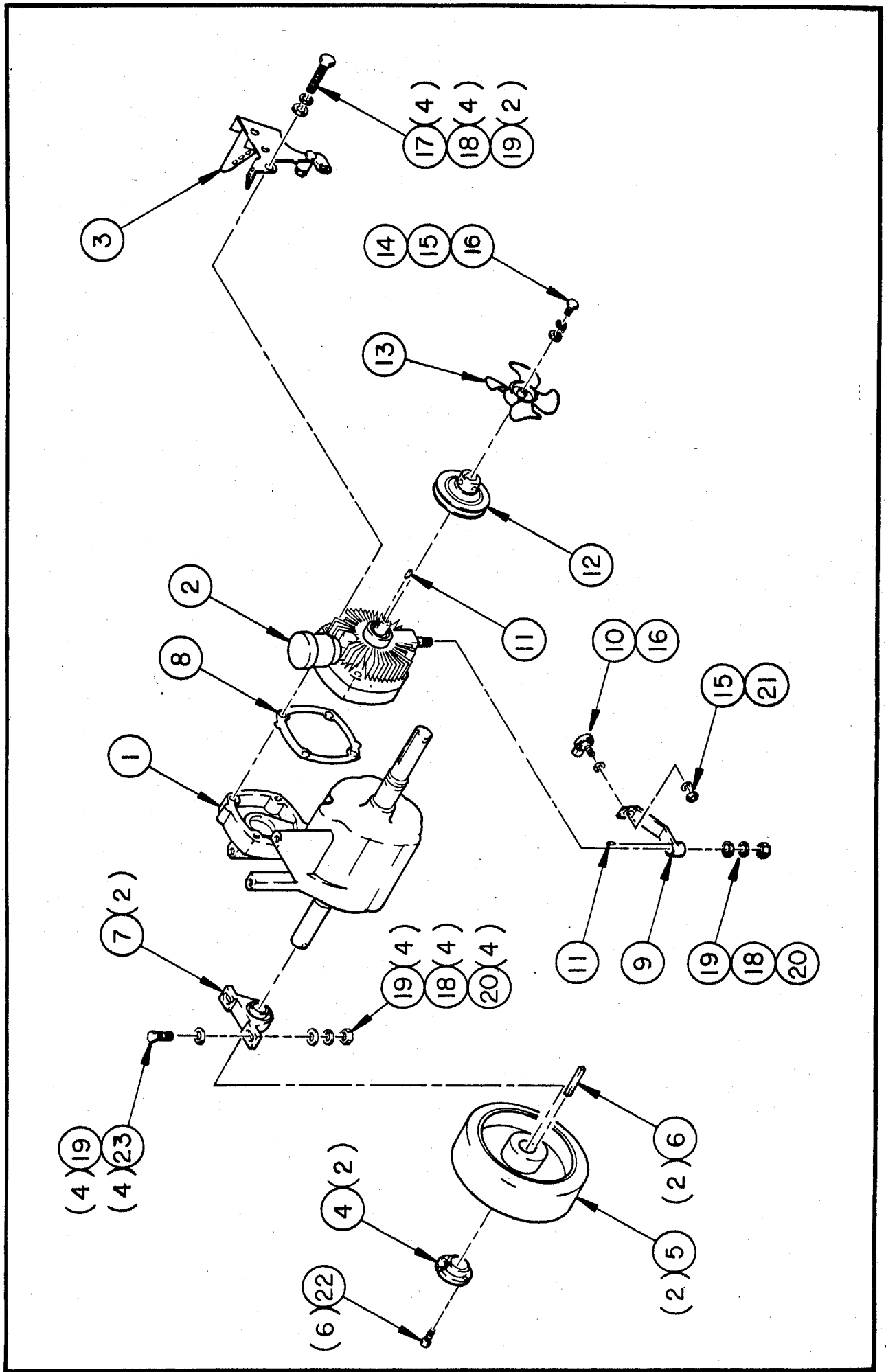

TRANSMISSION-DIFFERENTIAL

Parts List

ITEM	C/N	DESCRIPTION	QTY
1	20123	Differential (Locked).	1
2	30109	Transmission, Hydrostatic	1
3	10322	Plate, Cable Connector	1
	10364	Bracket, Neutral Actuator/Speed Control	1
4	30553	Bushing Q.D. 1"	2
5	30134	Wheel 10 x 3 x 1	2
6	10334-A	Square Key 1/4" x 3-1/4"	2
7	30263	Bearing, Pillow Block 1"	2
8	30257	Gasket, Hydrostatic Transmission	1
9	10591	Lever, Speed Control	1
10	30906	Ball-Joint 1/4"-28 x 1/4"-28	1
11	30594	Key, Woodruff 1/8" x 1/2"	2
12	30103	Pulley, Hydrostatic	1
13	30188	Fan, Plastic 6"	1
14		Screw, Hex 1/4"-20 x 1"	1
15		Washer, Splitlock 1/4"	2
16		Washer, Flat 1/4"	2
17		Screw, Hex 3/8"-16 x 3"	4
18		Washer, Splitlock 3/8"	9
19		Washer, Flat 3/8"	11
20		Nut, Hex 3/8"-16	5
21		Nut, Hex 1/4"-28	1
22		Screw, Socket Head Cap 10-24 x 1"	6
23		Screw, Hex 3/8"-16 x 1-3/4"	4

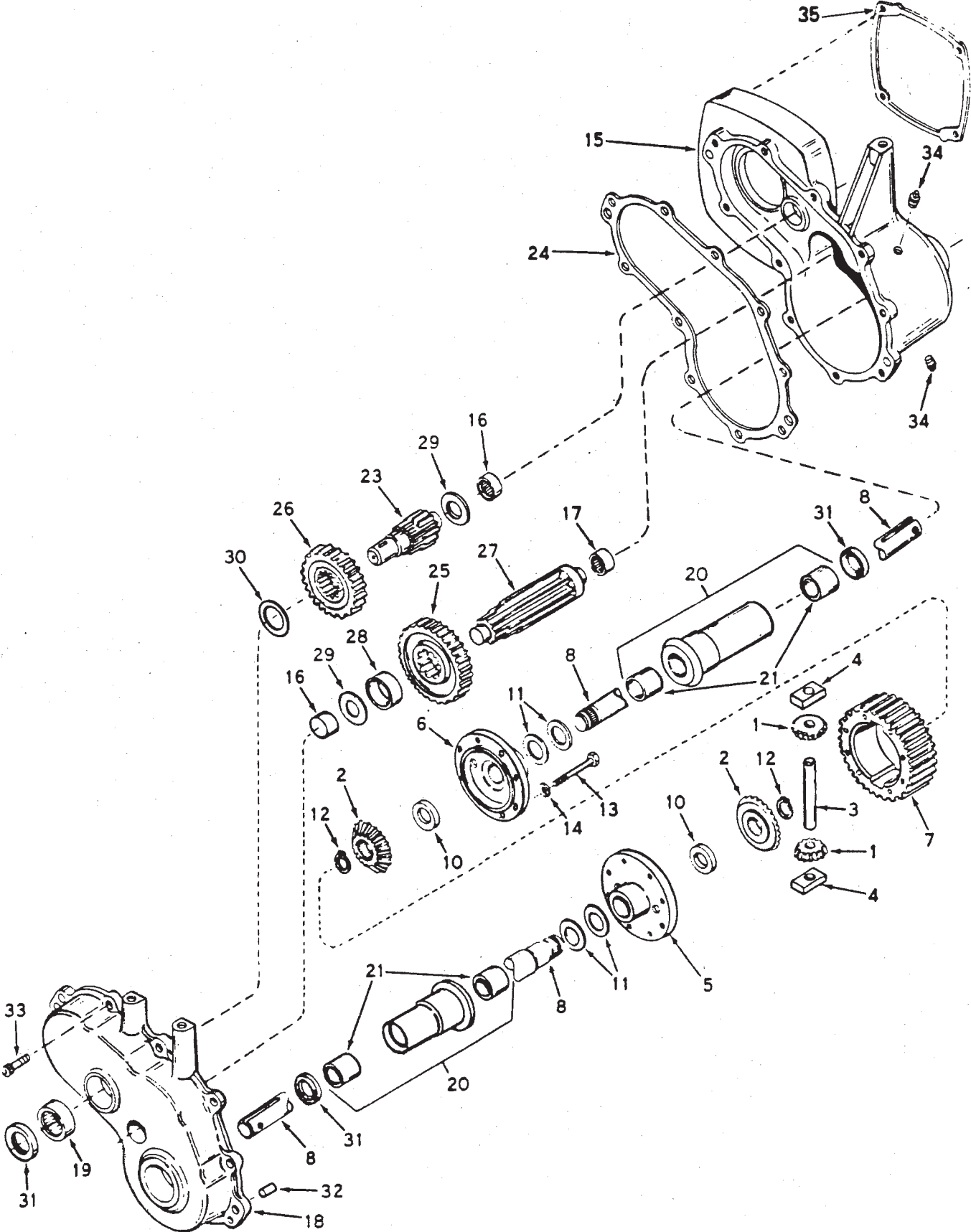

TECUMSEH PRODUCTS COMPANY
 Engine And Gear Service Division
 Grafton, Wisconsin

<u>REF. NO.</u>	<u>PART NUMBER</u>	<u>PART NAME</u>
1	778197	Gear, Bevel pinion
2	778198	Gear, Bevel
3	786019	Pin, Drive
4	786027	Block, Drive
5	774028A	Carrier, Differential
6	774029A	Carrier, Differential
7	778033A	Gear, Ring
8	774159	Axle (11-7/16" long)
10	780107	Washer
11	780042	Washer, Thrust
12	792018	Ring, Snap
13	792020	Screw, Hex hd., 1/4-20 x 2-1/4
14	792006	Lockwasher, 1/4"
15	770052	Case Assy. (Incl. Nos. 16 & 17)
16	780013	Bearing, Needle
17	780088	Bearing, Needle
18	772063	Cover Assy. (Incl. Nos. 16 & 19)
19	780083	Bearing, Needle
20	782022A	Housing Assy., Axle (Incl. 2 of No. 21) (4-21/32" long)
21	780054	Bushing
23	776093	Shaft, Brake
24	788044	Gasket, Case-to-cover
25	778036	Gear, Output
26	778037	Gear, Idler
27	778041	Shaft, Output
28	786017	Spacer
29	780001	Washer
30	780090	Washer
31	788008	Seal, Oil
32	786026	Pin, Dowel
33	792046	Screw, Hex hd. self-tapping, 1/4-20 x 1
34	792010	Plug, Pipe
35	788046	Gasket

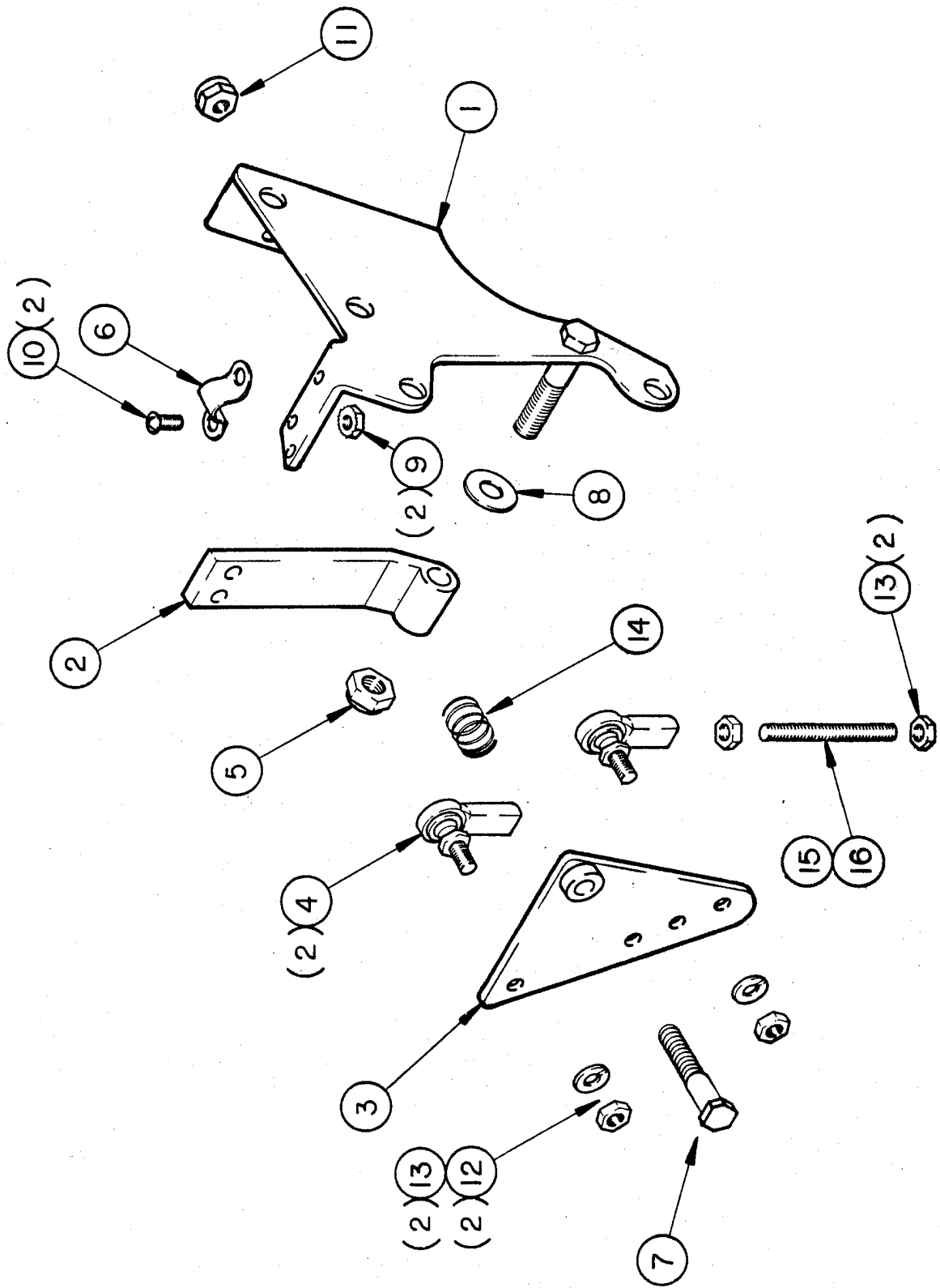

NEUTRAL ACTUATOR

SPEED CONTROL ASSY

ITEM	C/N	DESCRIPTION	QTY
1	10364	Bracket, Neutral Actuator/Speed Control	1
2	10338	Actuator, Neutral	1
3	10322	Plate, Cable Connector	1
4	30906	Ball-Joint, 1/4-28 x 1/4-28	2
5		Nylon Nut 3/8-16	1
6	30181	Clamp, Cable # 161-011-001	1
7		Screw, 5/16-18 x 1-1/2"	1
8		Washer, Flat 3/8" SAE	1
	30452	Collar, 3/8" (USED WITH WATER PUMP)	1
9		Nut, Keps 10-32	2
10		Screw, Pan Head Phillips 10-32 x 3/4"	2
11		Nylon Nut 5/16-18	1
12		Washer, Splitlock 1/4"	2
13		Nut, Hex 1/4"-28	2
14	32659	YY68 Spring	1
15	10552	Rod, All Threaded 1/4"-28 x 2-1/2"	1
16	10551-A	Rod, All Threaded 1/4"-28 x 11"	1

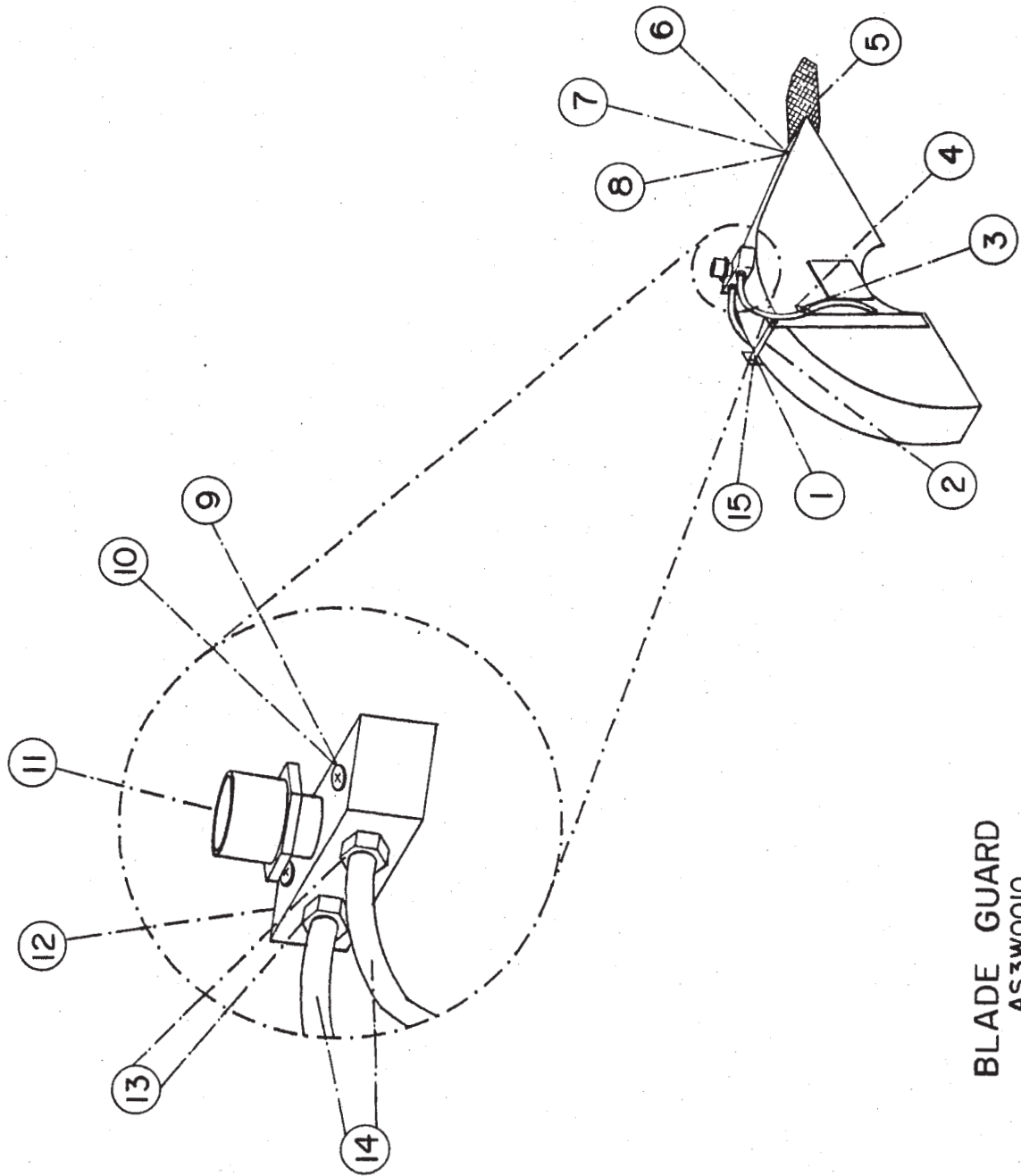

BLADE GUARD
AS3W0010

FLAT SAW

BLADE GUARDS SIZE

(QUANTITY)

IT	C/N	DESCRIPTION	14"	18"	20"	22"	24"	26"	30"	32"	36"	42"	48"	52"	60"	66"	72"
1		Cap Screw 3/8-16 x 3"	1	1	1	1	1	1									
		Cap Screw 3/8-16 x 4"							1	1	1	1	1	1	1	1	1
2	10570	Ins. Nylon Hinge 2-5/16	1	1	1	1	1	1									
	10427	Ins. Nylon Hinge 3-1/4"							1	1	1	1	1	1	1	1	1
3	30547	Jiffy Clamps 3/8" # 115	2	2	2	2	4	4	4	4	4	4	4	4	4	4	4
4	30715	Buttonhead Rivet 3/16"	2	2	2	2	4	4	4	4	4	4	4	4	4	4	4
5	30391	Blade Guard Flaps 8"x6"	1	1	1	1	1	1	1	1	1	1	1	1	1	1	1
6	33300	Cap Screw 1/4"x3/4" USS	1	1	1	1	1	1	1	1	1	1	1	1	1	1	1
7	30695	Fender Washer 1/4 (9/32) x1-1/2	1	1	1	1	1	1	1	1	1	1	1	1	1	1	1
	30692	Fender Washer 1/4 (9/32) x2"							1	1	1	1	1	1	1	1	1
8	33005	Ins. Nylon Lock Nut 1/4-20	1	1	1	1	1	1	1	1	1	1	1	1	1	1	1
9	30712	Phill Pan Hd. 10-32 x 1-1/2"	2	2	2	2											
	30709	Phill Round Mach 10-32 x 2"					2	2	2	2	2	2	2	2	2	2	2
10	33104	Keps Lock Nut 10-32	2	2	2	2	2	2	2	2	2	2	2	2	2	2	2
11	30393	Fitting NU22-8-12	1	1	1	1	1	1	1	1	1	1	1	1	1	1	1
12	10299	Manifold Water Blk. (3-Ports)	1	1	1	1											
	10288	Manifold Water Blk. (5-Ports)					1	1	1	1	1	1	1	1	1	1	1
13	30394	Hose Barb 125-4-2	2	2	2	2	4	4	4	4	4	4	4	4	4	4	4
14	30492	Clear Hose 1/4"	2	2	2	2	4	4	4	4	4	4	4	4	4	4	4
15	33011	Ins. Nylon Jam Nut 3/8-16	1	1	1	1	1	1	1	1	1	1	1	1	1	1	1

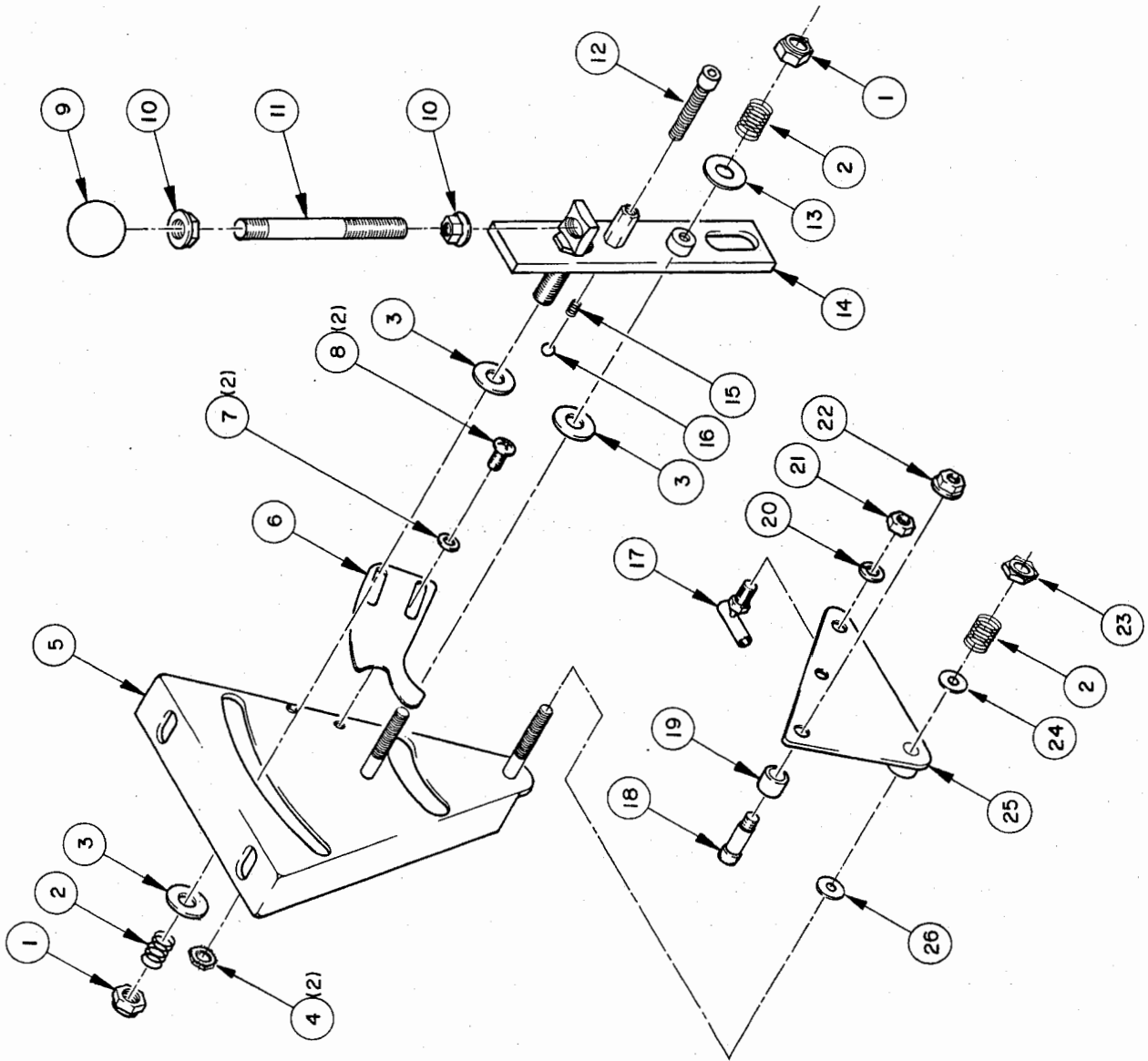

SPEED CONTROL

ITEM	C/N	DESCRIPTION	QY
1		Nylon Lock Nut 3/8-16	2
2		Spring B-6	3
3		Washer Hard 3/8 x 7/8 x 1/8	3
4		Keeps Nut 10-32	2
5	10320-1	Forward & Reverse Bracket	1
6	10323	Plate Index, Forward & Reverse	1
7		Washer Flat # 10	2
8		Screw Phillips 10-32 x 1/2	2
9	30339	Knob 3/8-16 x 1-3/8 Dia	1
10		Nut Flanged 3/8-16	2
11		Stud 3/8-16 x 4" (M-18,20,23 & 25)	1
11		Stud 3/8-16 x 5" (M-35 & 65)	1
12		Socket Head Cap Screw 1/4-20 x 5/8"	1
13		Flat Washer 5/16" USS	1
14	10321-1	Lever, Shift Forward & Reverse	1
15		Spring BB-7	1
16	30885	Ball SS 5/16" Dia	1
17	30906	Balljoint 1/4-28 x 1/4-28	1
18		Shoulder Screw 5/16 x 1/2; 1/4-20 Thr.	1
19	10324	Bushing 5/16 x 1/2 x 7/16	1
20		Washer Splitlock 1/4"	1
21		Hex Nut 1/4-28	1
22		Nylon Jam Nut 1/4-20	1
23		Nylon Nut 5/16-18	1
24		Flat Washer 5/16" SAE	1
25	10322	Plate Cable Conn. Forward & Reverse	1
26		Flat Washer 5/16" 0.060 H.S. Zinc P.	1

ITEM#	PART#	DESCRIPTION	QTY
1	11402-1	handle, m 27, M15 E, M25 H.C.	1
1	11402	handle, m 35, 20E, 30E, 30D.	1
1	11403	handle, M65SS, M60DSS, M30ESS, M40ESS.	1
1	11404	handle, 37 nissan 2001 TD 2003	1
1	30154-2	handle, M65, M60D, M40D, M40E, M72FP.	1
1	11704	handle, M42FL, M37, M44, M48.	1
1	11704	handle, 62SS perkins F. P. & R. P.	1
1	11919	handle, 62 wc perkins R. P.	1
2		5/8 flat washer	2
3	30150	spring	1
4		5/8-11 jam nut	1
5		5/8 split washer	1
6		5/16-18x1 allen head screw	1
7		5/16 flat washer	1
8	11405	1.125 x 11" upper part	1
9	WS049	5/8 seal	1
10	11406	5/8-11 lower part	1
11	11705	rod, 5/8-11 X 17.25 front pivot	1
12	11920	62ss wc 1-3g only	1
13	11933	62ss wc fp 1-3g only	1

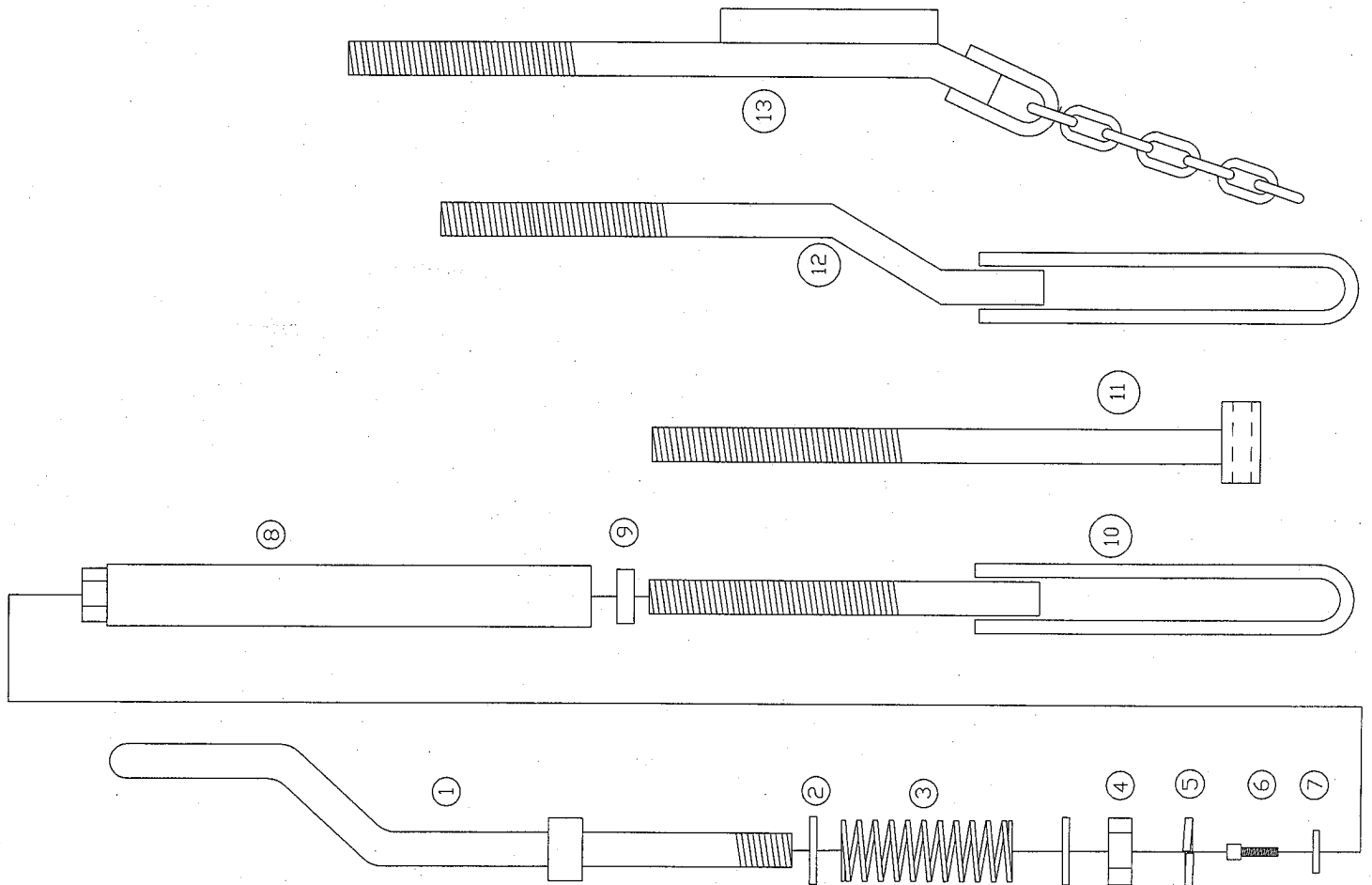

US WARRANTY STATEMENT

WARRANTY POLICY

All warranty claims will be determined after inspection at a designated facility. A Returned Goods Authorization is required for all warranty claims. Contact Husqvarna Customer Service Department at 800-845-1312 for an RGA. The customer must prepay the freight and absorb any labor expense required to return or replace a product submitted for warranty consideration. Husqvarna will pay return shipping expenses for repaired or approved replacement products.

EQUIPMENT

Equipment manufactured by Husqvarna is warranted to be free from manufacturing defects in normal service for a period of two (2) years from date of purchase by the original consumer purchaser. **Component manufacturers offer separate warranty periods. Call Technical Services at 800-288-5040 for complete information.**

Our obligation under this warranty is expressly limited to the replacement or repair at Husqvarna Construction Products North America, Olathe, Kansas 66061, or at a service facility designated by us, of such part or parts as inspection shall disclose to have been defective.

This warranty does not apply to defects caused by damage, unreasonable use, faulty repairs made by others than an approved Husqvarna servicing dealer, or defects caused by failure to provide reasonable maintenance, while in the possession of the consumer. Further, the warranty is void if the product, or any of its components, are altered or modified by the consumer purchaser, or if the product is used in an inappropriate manner or with tools not recommended by the manufacturer.

Exceptions: Drill motors - 3 months, Wall saws - 1 year, Power cutters - 3 months, DM230 - 1 year, DM225 - 3 months, Gyro systems - 1 year, CD40 system - 1 year, DS160 C - 1 year, Smart box - 1 year, CS2515 - 1 year, PP455 E - 1 year, PP345 E - 1 year, HP40 - 1 year.

Wear items: Filters, spark plugs, bearings*, belts, wheels** and wear pads.

*Except IntelliSeal™ system. **Except delamination.

Original instructions



www.husqvarnacp.com

1156337-27

2013-09-03