



# SPARE PARTS LIST

TILE SAWS

MS360, 2015-06



Ref	Part No	Description	Remark	QTY KIT
1	585 56 39-01	COVER		1
2	725 53 72-01	SCREW IHSCM		3
3	510 22 54-37	WRENCH		1
4	588 10 99-02	WRENCH		1
5	588 10 99-01	WRENCH		1
6	585 54 53-01	CLIP		1
7	734 11 63-01	WASHER		6
8	725 24 49-71	SCREW EHHM		2
9	585 23 64-01	BRACKET		1
10	584 14 69-01	WASHER		1
11	585 59 50-01	KNOB		1
12	585 62 09-02	BUSH		2
13	585 54 96-01	BRACKET		1
14	725 62 95-01	SCREW IHCSFM		2
15	585 23 46-01	ARM		1
16	588 56 82-01	ADJUSTER		2
17	588 11 63-01	BRACKET		5
18	504 58 11-01	WASHER		5
19	732 25 18-01	HEXAGON LOCKING NUT		5

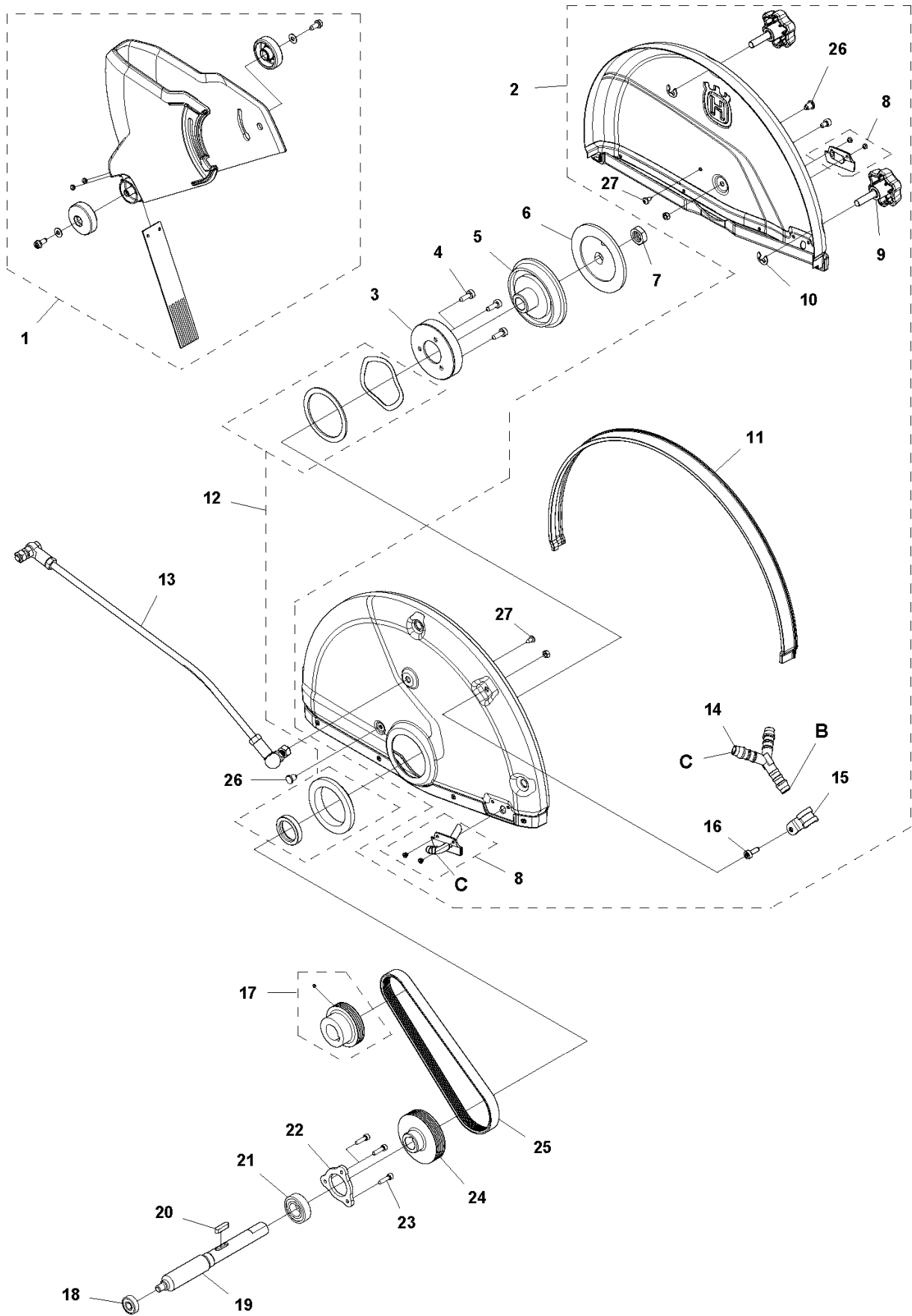

Ref	Part No	Description	Remark	QTY KIT
1	586 78 29-01	SPLASH GUARD		1
2	588 92 78-01	BLADE GUARD		1
3	587 98 98-01	WASHER		1
4	725 53 27-01	SCREW IHSCM		3
5	581 55 73-01	FLANGE WASHER		1
6	581 55 74-01	FLANGE WASHER		1
7	576 68 23-01	NUT		1
8	501 08 07-01	NOZZLE		1
9	585 59 50-01	KNOB		2
10	735 31 12-21	E-CLIP		2
11	585 24 63-01	SEALING		1
12	588 92 79-01	WEAR WASHER		1
13	586 51 07-01	PARALLEL ROD		1
14	585 24 55-01	HOSE CONNECTOR		1
15	585 24 56-01	CLIP		1
16	725 53 23-01	SCREW IHSCM		1
17	588 95 85-01	PULLEY KIT	Ø24 mm	1
17	588 95 85-02	PULLEY KIT	Ø19 mm	1
18	525 81 67-01	BEARING		1
19	585 20 87-01	BLADE SHAFT		1
20	581 55 95-01	PARALLEL KEY		1
21	738 21 03-04	BALL BEARING		1
22	586 71 24-01	FLANGE		1
23	725 52 91-01	SCREW IHSCM		3
24	580 81 49-01	PULLEY		1
25	581 55 91-01	BELT		1
26	579 07 17-01	KNOB		1
27	729 53 40-01	SCREW CCRPANT		1

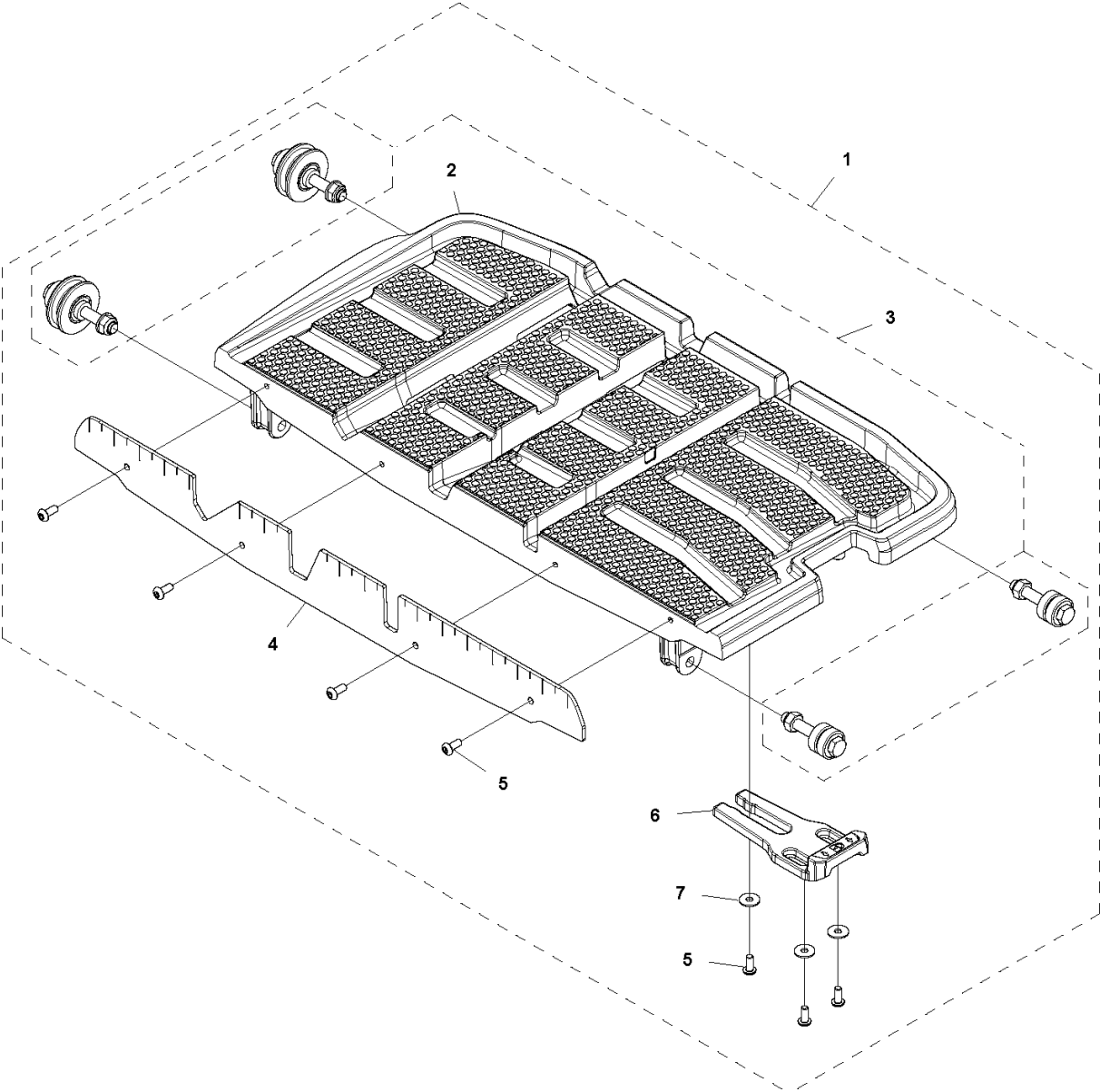

## CART

MS360, 2015-06

Ref	Part No	Description	Remark	QTY	KIT
1	581 34 25-01	CART		1	
2	580 27 84-01	CART		1	1
3	588 91 58-01	WHEEL KIT		1	1
4	581 34 33-01	SUPPORT		1	1
5	725 53 27-01	SCREW IHSCM		7	1
6	580 27 63-01	HANDLE		1	1
7	734 11 47-41	WASHER		3	1

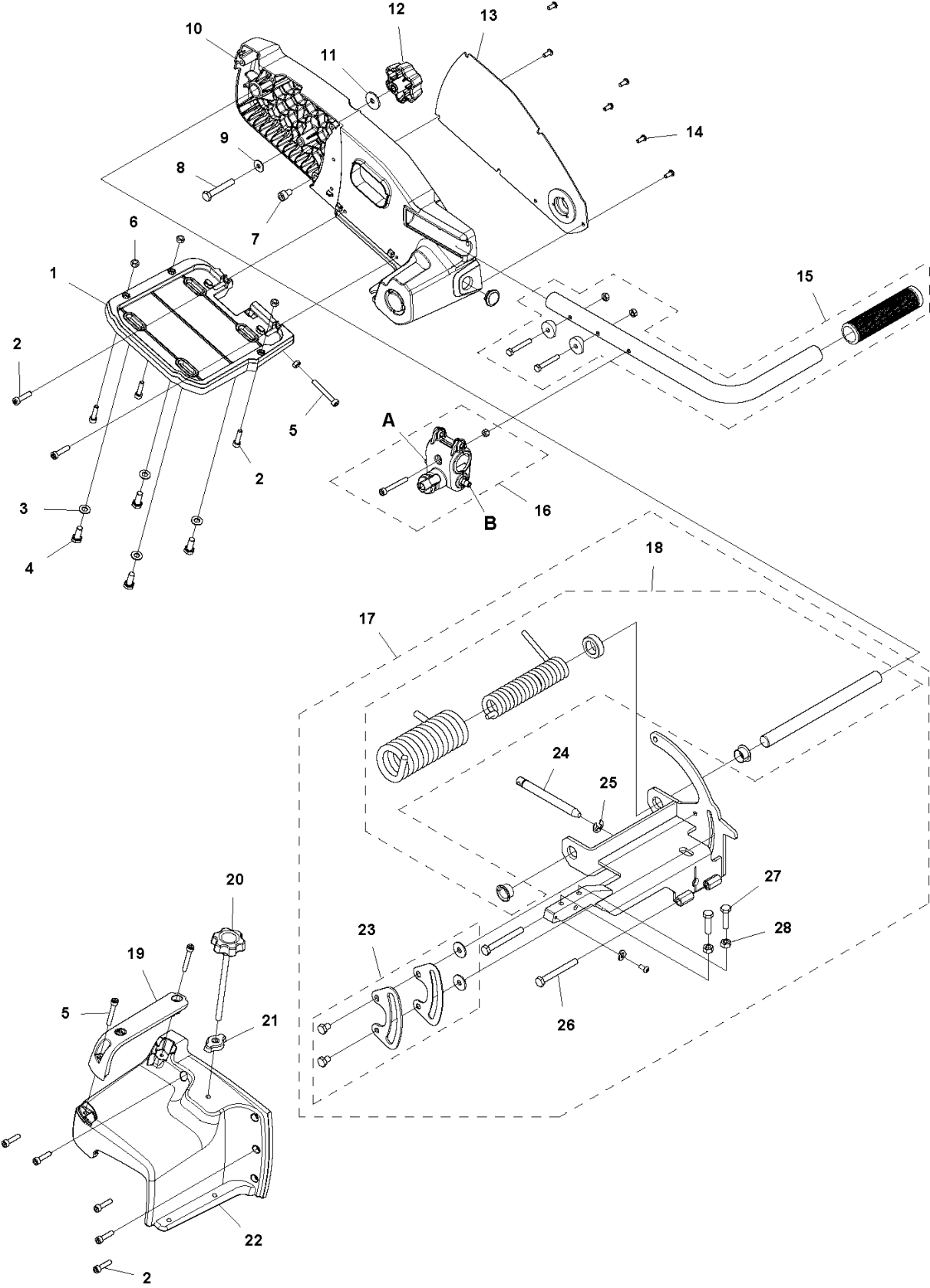



## CUTTING HEAD

MS360, 2015-06

Ref	Part No	Description	Remark	QTY	KIT
1	586 33 26-01	MOTOR SUPPORT		1	
2	725 53 72-01	SCREW IHSCM		10	
3	734 11 63-01	WASHER		4	
4	725 24 51-71	SCREW EHHM		4	
5	588 80 40-01	SCREW IHSCM		3	
6	732 25 16-01	HEXAGON LOCKING NUT	2 are included in kit 15	6	
7	725 54 47-01	SCREW IHSCM		1	
8	725 24 63-51	SCREW EHHM		1	
9	584 14 69-01	WASHER		1	
10	581 09 90-01	CUTTER ARM		1	
11	588 85 07-01	WASHER		1	
12	585 59 50-05	KNOB		1	
13	585 61 28-01	BELT COVER		1	
14	725 53 27-01	SCREW IHSCM		6	
15	588 91 57-02	HANDLE KIT		1	
16	501 08 09-01	VALVE		1	
17	586 83 02-01	JOINT		1	
18	588 91 84-01	SPRING		1	17
19	586 38 00-01	HANDLE		1	
20	585 59 50-02	KNOB		1	
21	522 77 44-03	KNOB		1	
22	581 27 99-01	CUTTER ARM		1	
23	588 91 85-01	PLATE KIT		1	17
24	587 40 94-01	AXLE		1	17
25	579 48 28-01	E-CLIP		1	17
26	725 24 65-51	SCREW EHHM		2	17
27	725 24 59-71	SCREW		2	17
28	731 23 18-01	HEXAGON NUT		2	17

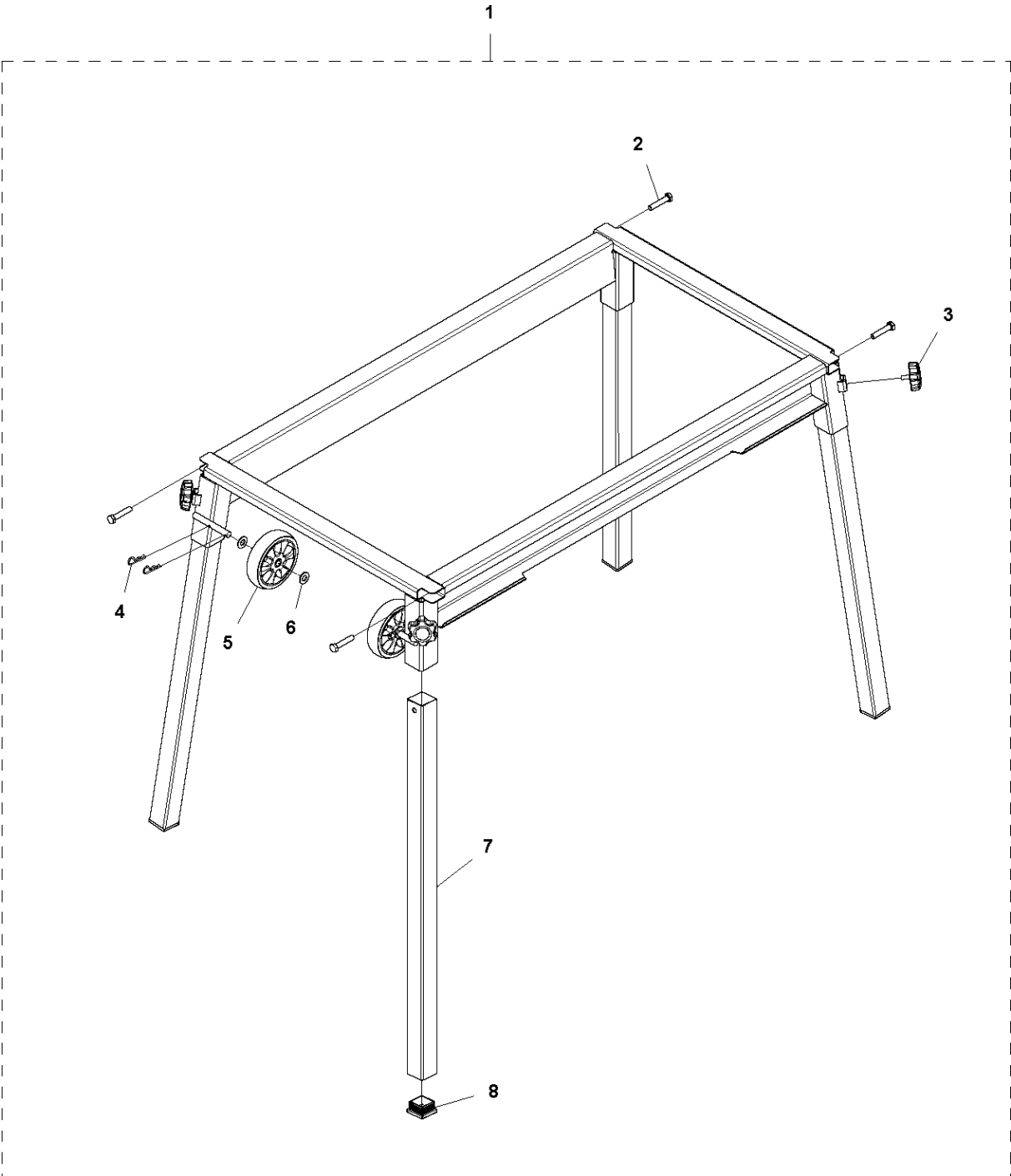

FIXED STANDS

MS360, 2015-06

Ref	Part No	Description	Remark	QTY KIT
1	579 59 64-01	STAND		1
2	725 24 59-71	SCREW		4
3	585 59 50-03	KNOB		4
4	721 68 01-51	SPRING COTTER		2
5	510 22 54-27	WHEEL		2
6	734 11 72-01	WASHER		4
7	579 59 63-01	PROFILE		4
8	585 52 97-01	CAP		4

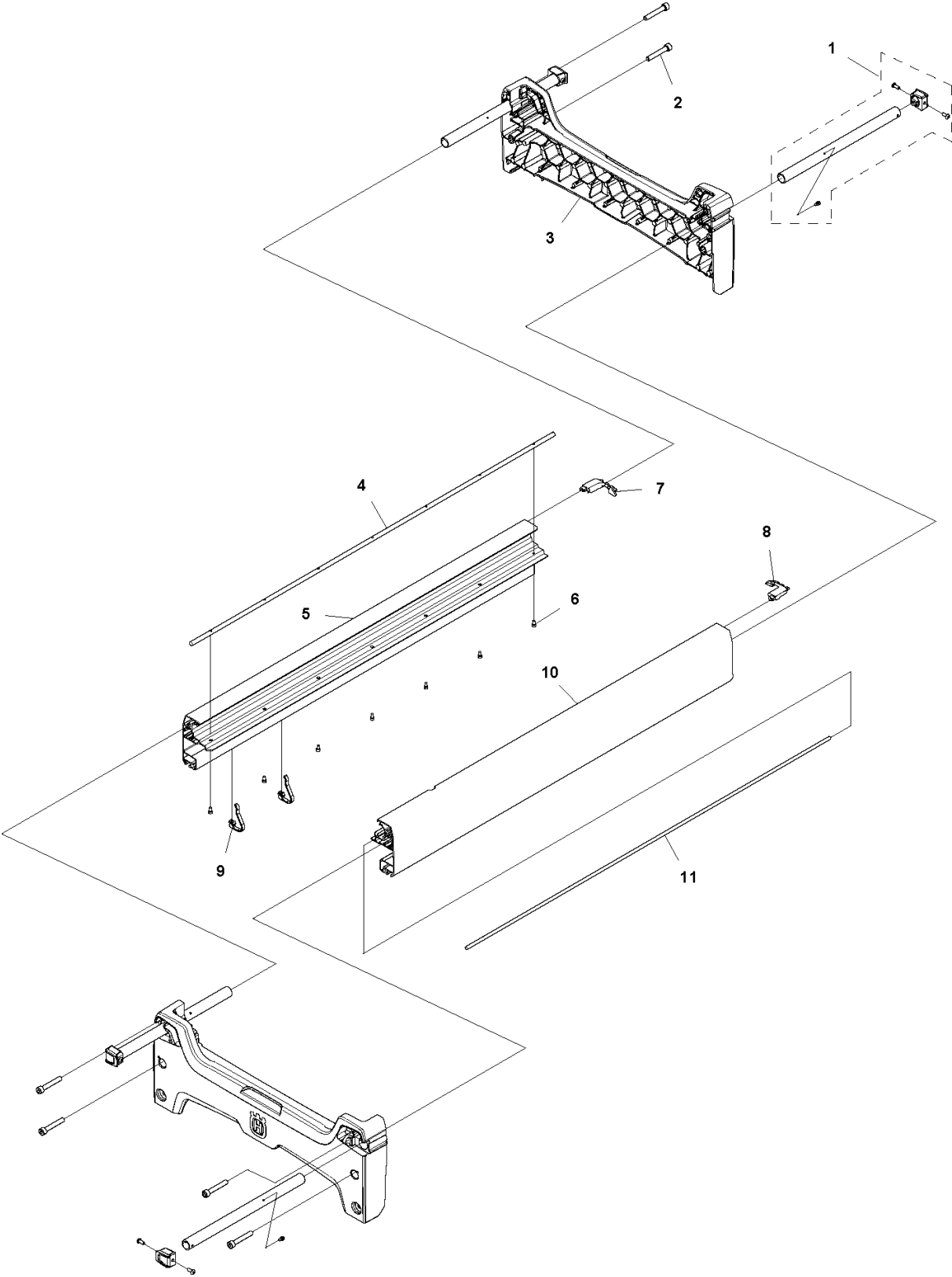

Ref	Part No	Description	Remark	QTY KIT
1	580605601	TBD		4
2	725 54 61-01	SCREW IHSCM		8
3	585 23 61-01	GABLE		2
4	585 54 38-02	ROD		1
5	584 92 99-01	PROFILE		1
6	588 71 93-01	SCREW IHSCM		7
7	585 51 92-01	PLUG		1
8	585 51 93-01	PLUG		1
9	581 56 07-01	CLIP		2
10	584 93 00-01	PROFILE		1
11	585 54 40-03	ROD		1

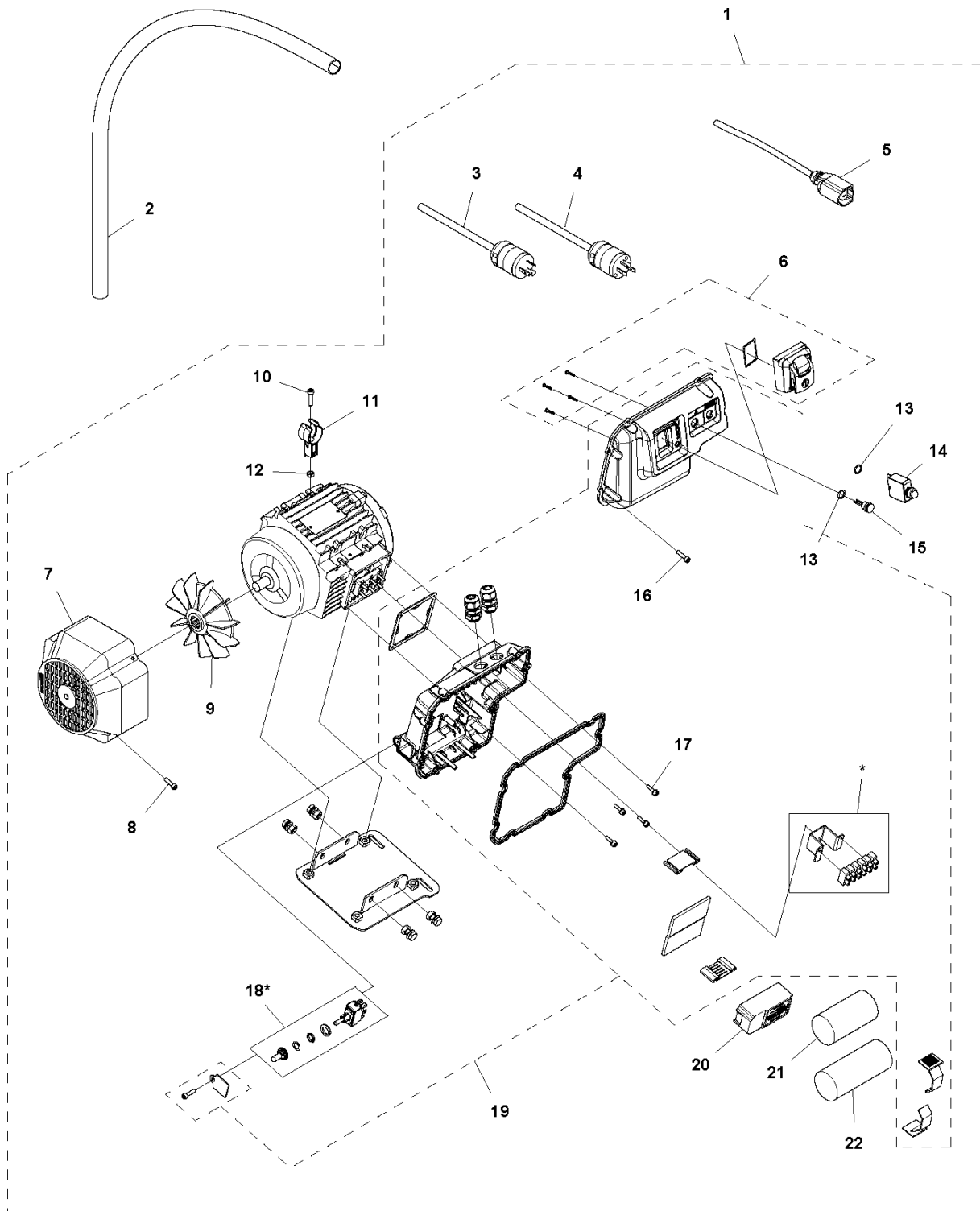

\* ONLY DUAL VOLTAGE

## MOTOR

MS360, 2015-06

Ref	Part No	Description	Remark	QTY KIT
1	585 22 54-01	MOTOR	115V/230V,1,1 kW,60Hz CPL	1
1	585 22 54-02	MOTOR	230V, 2.2 kW, 60Hz CPL	1
1	585 22 54-03	MOTOR	115V/230V,1,5kW,60Hz CPL	1
1	585 22 54-04	MOTOR	115V,1,1 kW,60Hz CPL	1
2	585 54 54-02	HOSE		1
3	586 36 93-02	CABLE	Used for: 585 22 54-04	1
4	586 36 93-03	CABLE	Used for: 585 22 54-01/- 02/-03	1
5	525 81 45-02	CABLE		1
6	588 92 96-01	SWITCH KIT		1
7	589 23 41-01	FAN COVER	Used for: 585 22 54-04	1
7	589 23 41-02	FAN COVER	Used for: 585 22 54-01/- 02/-03	1
8	724 13 23-01	SCREW CRPANM		4
9	589 23 45-01	FAN	Used for: 585 22 54-04	1
9	589 23 45-02	FAN	Used for: 585 22 54-01/- 02/-03	1
10	725 53 70-01	SCREW IHSCM		1
11	585 54 53-01	CLIP		1
12	732 25 16-01	HEXAGON LOCKING NUT		1
13	587 92 36-01	O-RING	Qty 3 in dual voltage	2
14	585 54 41-01	ADAPTER	Used for: 585 22 54-02	1
14	585 54 41-02	CIRCUIT BREAKER	Used for: 585 22 54-01/-04	1
14	585 54 41-03	CIRCUIT BREAKER	Used for: 585 22 54-03	1
15	580 88 16-04	LAMP		1
15	580 88 16-03	LAMP	Used for: 585 22 54-02	1
16	725 53 31-05	SCREW IHSCM		9
17	725 52 93-01	SCREW IHSCM		4
18	589 23 58-01	SWITCH KIT	Dual voltage	1
19	588 91 91-01	ELECTRONIC BOX		1
20	586 29 40-01	ELECTRONIC BOX	Used for: 585 22 54-02	1
20	586 29 40-02	ELECTRONIC BOX		1
21	585 54 44-01	CAPACITOR	Used for: 585 22 54-01/-04	1
21	585 54 44-02	CAPACITOR	Used for: 585 22 54-03	1
21	585 54 44-03	CAPACITOR	Used for: 585 22 54-02	1
22	585 54 45-01	CAPACITOR	Used for: 585 22 54-01/-04	1
22	585 54 45-02	CAPACITOR	Used for: 585 22 54-03	1
22	585 54 45-03	CAPACITOR	Used for: 585 22 54-02	1

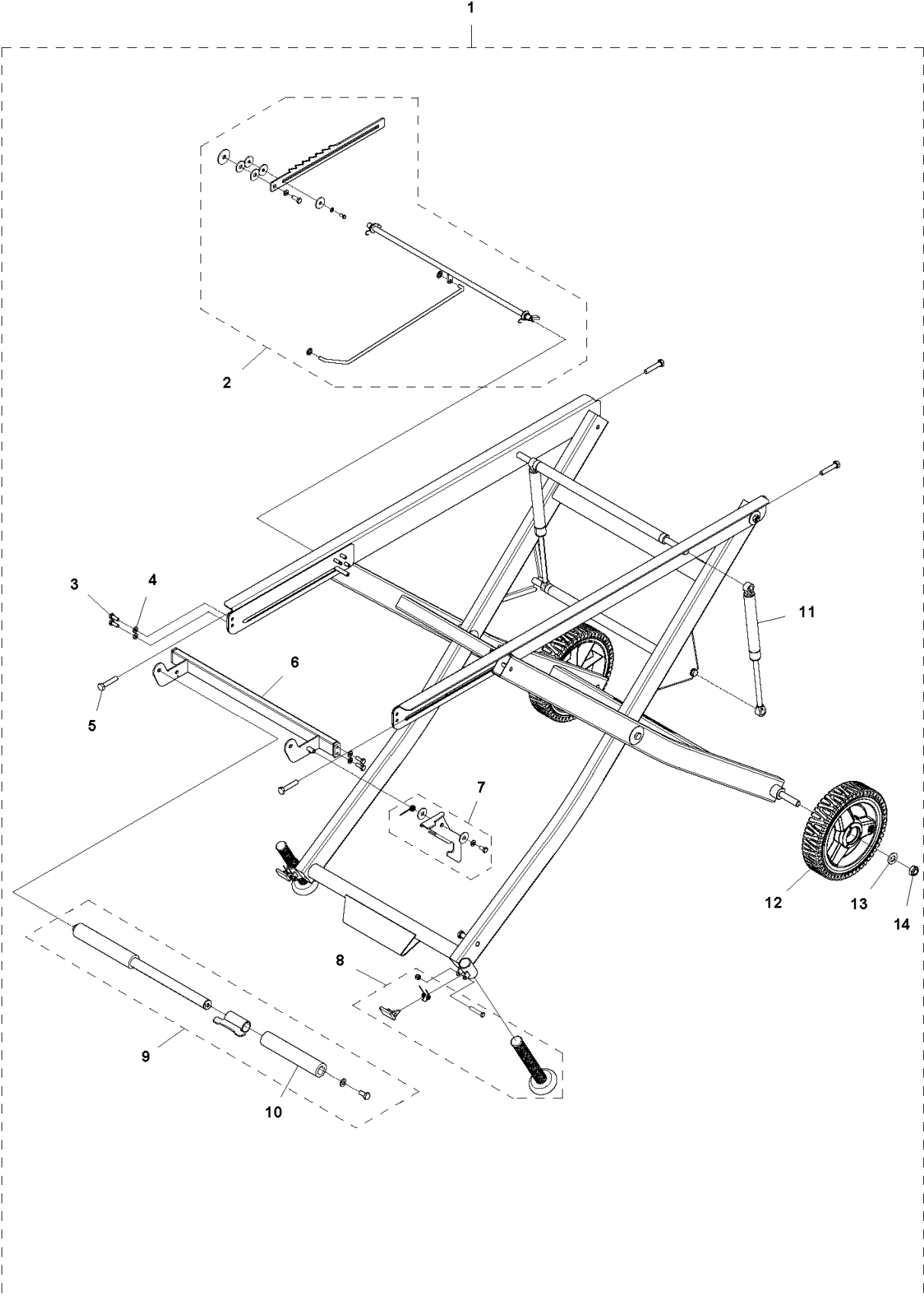



## STANDS

MS360, 2015-06

Ref	Part No	Description	Remark	QTY KIT
1	585 58 16-01	STAND		1
2	589 02 20-01	LOCK		1
3	725 23 68-71	SCREW EHHM		6
4	734 11 52-01	WASHER		7
5	725 24 59-71	SCREW		4
6	581 22 12-01	HANDLEBAR		1
7	589 02 21-01	LOCKING LEVER		1
8	589 02 27-01	SUPPORT LEG		2
9	589 02 22-01	HANDLE KIT		1
10	581 22 64-01	HANDLE		2
11	579 53 20-01	GAS SPRING		2
12	532 40 12-73	WHEEL & TIRE ASSY, FRONT		2
13	734 11 78-01	WASHER		2
14	732 25 22-01	HEXAGON LOCKING NUT		2

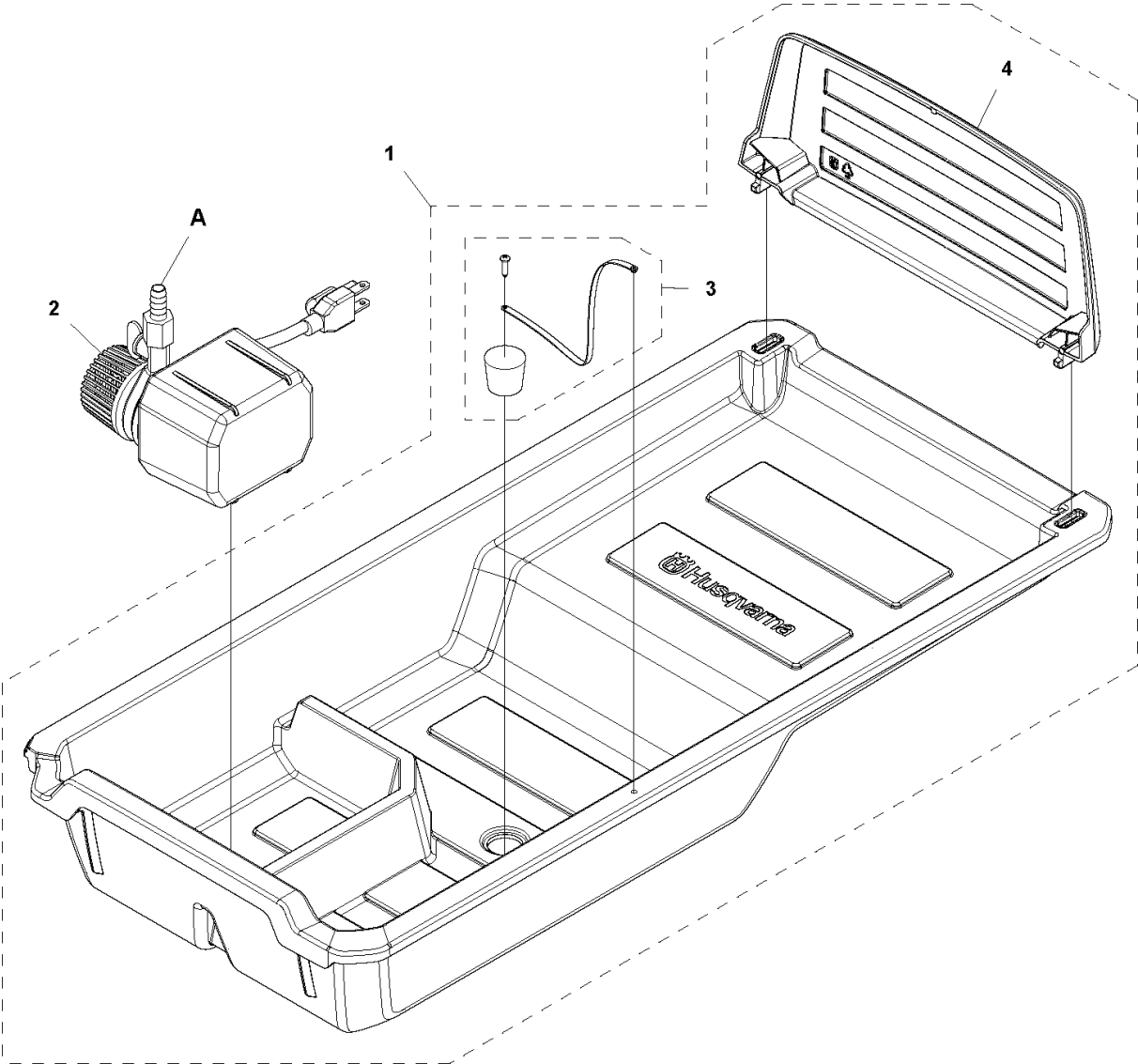
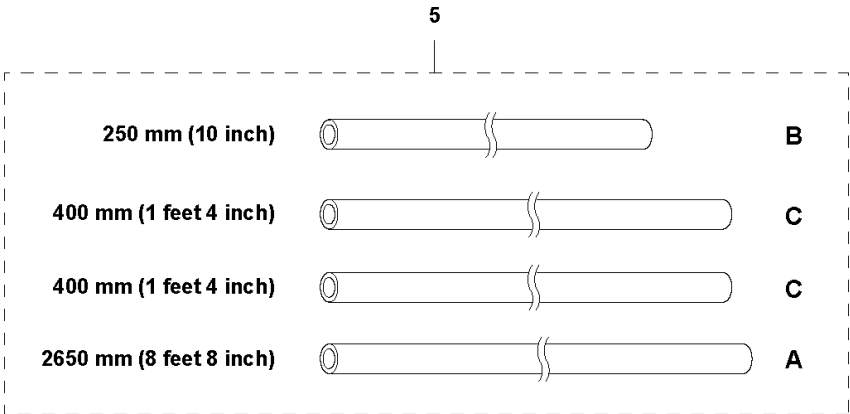

WATER TANK

MS360, 2015-06

Ref	Part No	Description	Remark	QTY KIT
1	586 59 62-01	TRAY		1
2	586 66 83-01	PUMP		1
3	583 95 17-01	PLUG KIT		1
4	585 56 43-01	SPLASH GUARD		1
5	585 56 62-02	TUBE		1