

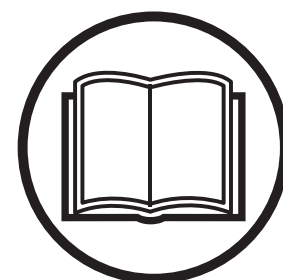

Husqvarna®



## Operator's manual TS 350E



Please read the operator's manual carefully and make sure you understand the instructions before using the machine.

**English**

FIG: 1

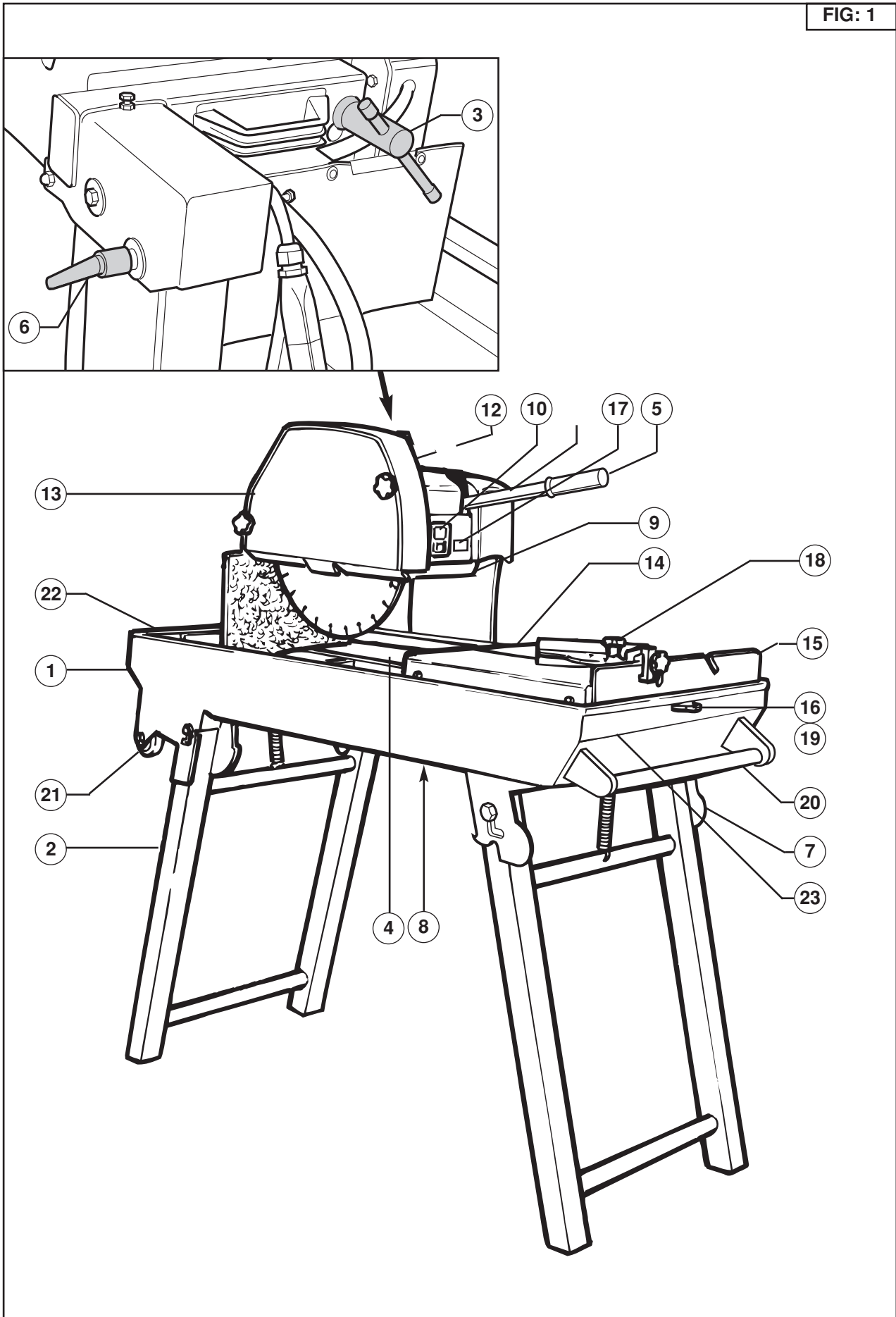

# Operator's manual - TS 350 E

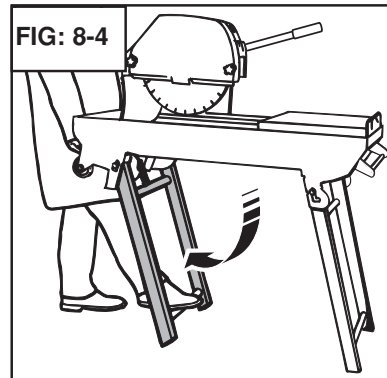
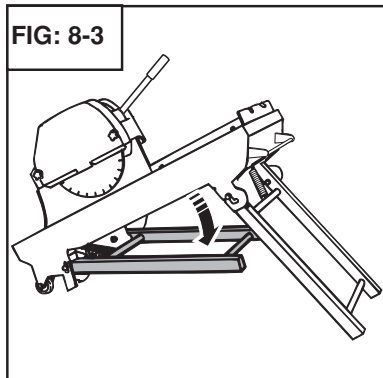
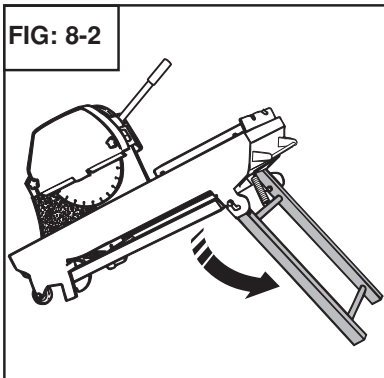
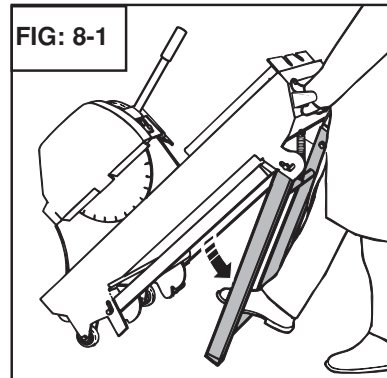
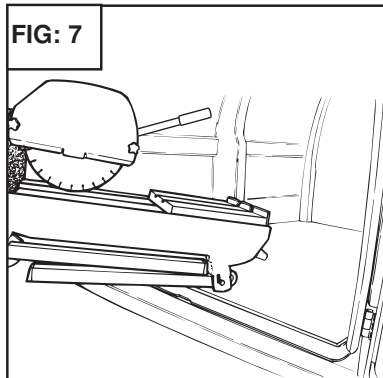
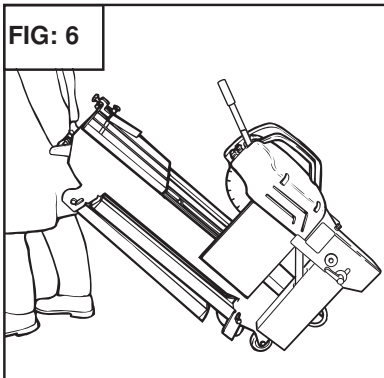
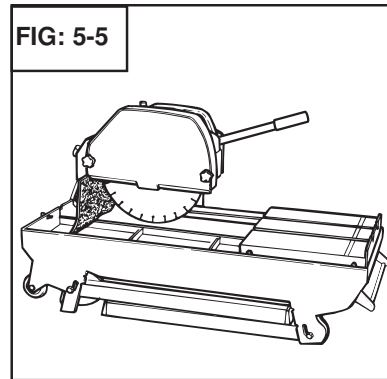
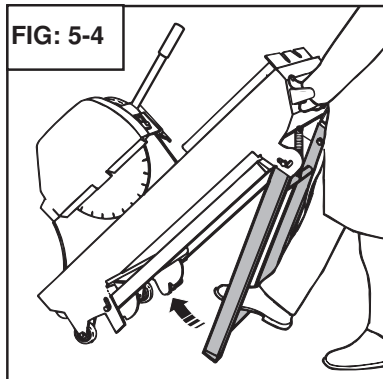
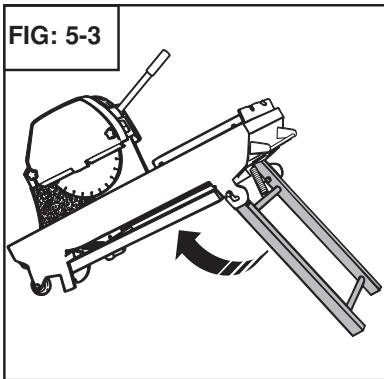
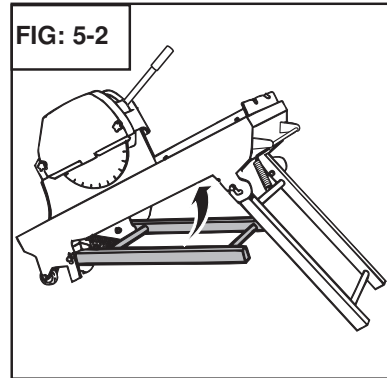
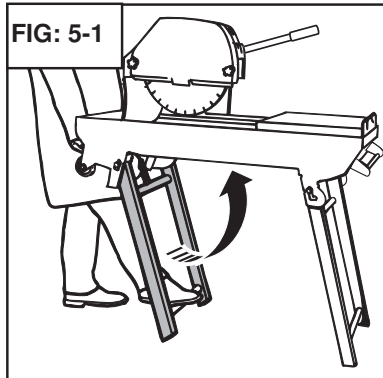
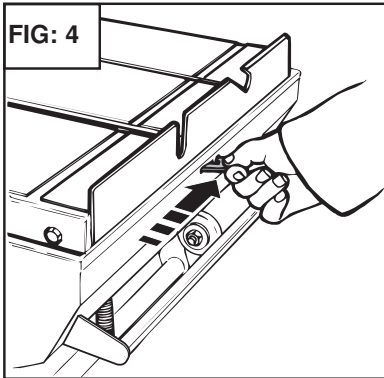
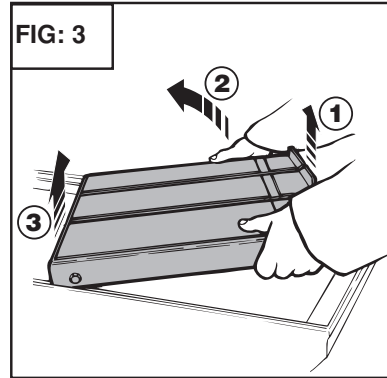
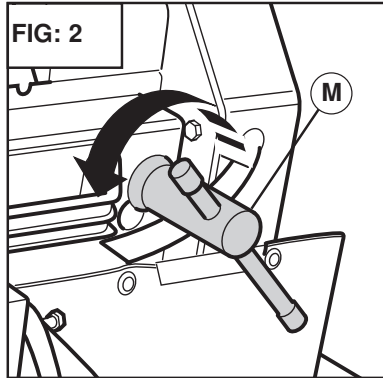

# Operator's manual - TS 350 E

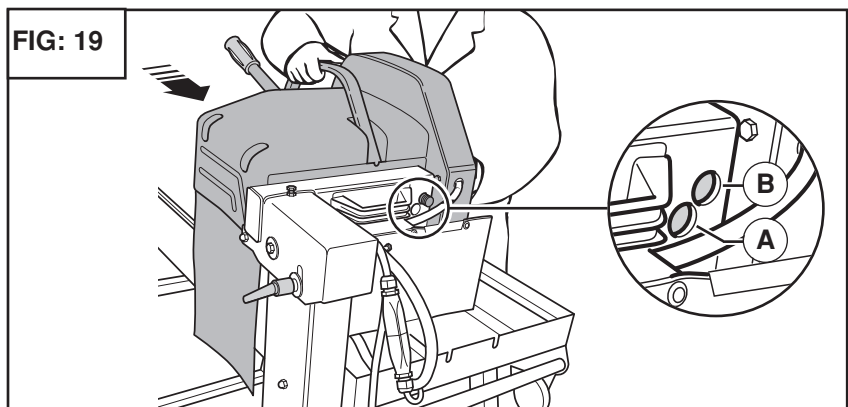
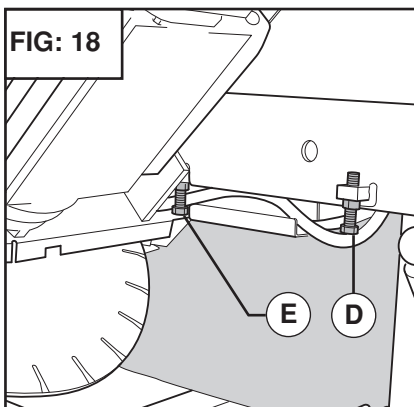
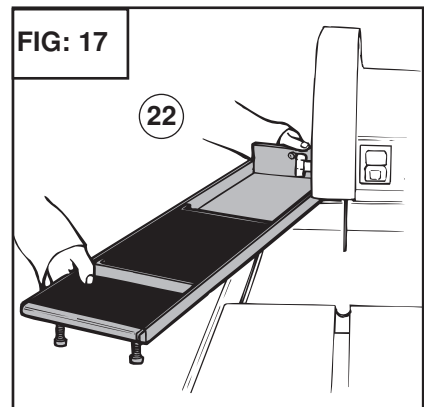
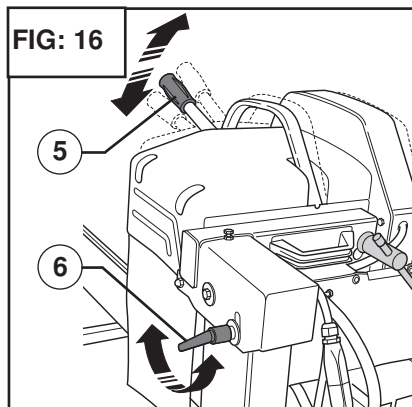
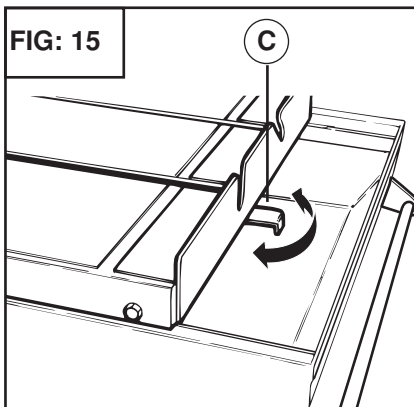
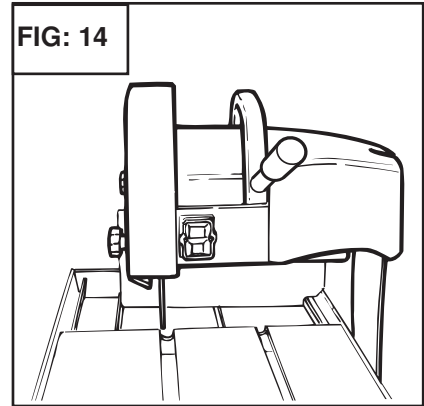
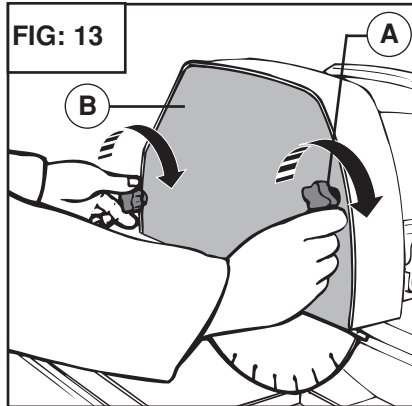
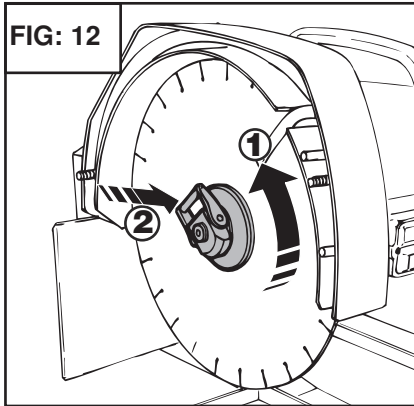
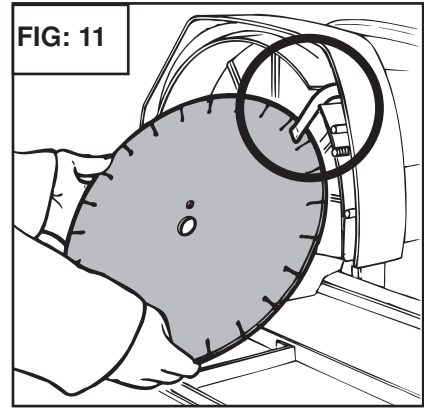
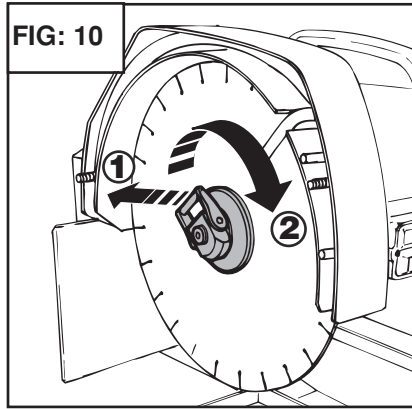
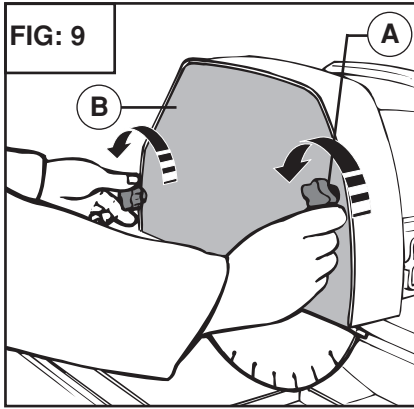

## Preface to the manual

Before leaving our factory every machine passes an exacting inspection programme in which everything is checked minutely.

Following the instructions will ensure that your machine gives long service, in normal operating conditions.

The user advice and spare parts mentioned in this document are given as an indication, and do not constitute an undertaking. No warrantee will be granted in the event of errors or omissions, or for damage occurring during delivery, or caused by the design or use of the machine. We are very concerned about the quality of our products and we reserve the right to make any technical modifications to improve them, without warning.

This document will:

- provide the user with: information about the machine
- information about its possible uses
- prevent accidents due to unsuitable use, by an untrained person, during maintenance, repairs, overhauls, handling or transport
- improve the reliability and durability of the machine
- ensure correct use, regular maintenance, and fast fault finding in order to reduce repair costs and downtime.

**The manual should always be available at the place of work. It should be read and used by any person installing or using the machine.**

**The obligatory technical regulations in force in the country where the machine is used must also be adhered to for maximum safety.**

**The manufacturer declines any responsibility resulting from improper use, or modifications.**

## General safety instructions

### WARNING

Danger symbol



### OBLIGATION

Blue background, white marking : obligatory safety red marking : movement forbidden



### WARNING

Black triangle and marking on a yellow background : danger if not adhered to. Risk of injury to the user or third parties, with possibility of damage to the machine or the tool.



### PROHIBITION

Red circle with or without bar : use or presence prohibited.



### INFORMATION

Information - Instruction: special instructions concerning use and inspection.

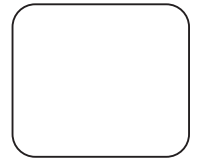

This symbol indicates that the machine is in conformance with the applicable European directive.



Environmental marking. Symbols on the product or its packaging indicate that this product cannot be handled as domestic waste.



By ensuring that this product is taken care of correctly, you can help to counteract the potential negative impact on the environment and people that can otherwise result through the incorrect waste management of this product.

For more detailed information about recycling this product, contact your municipality, your domestic waste service or the shop from where you purchased the product.

Instruction plate

LE FABRICANT		CE	
1	TYPE	6	N° SERIE
2	MASSE UTILE	7	ANNEE DE FABRICATION
3	Ø MAXI OUTIL	8	PUISSANCE
4	Ø ALESAGE	9	PLAGE DE TENSION
5	T.MIN - RPM	10	FREQUENCE
		11	INT. UTIL.

- |                     |               |              |
|---------------------|---------------|--------------|
| 1. Type             | 2. Weight     | 3. Maxi tool |
| 4. Bore             | 5. Speed      | 6. Serial    |
| 7. Fabrication year | 8. Power      | 9. Voltage   |
| 10. Frequency       | 11. Intensity |              |

## Special instructions

The disc cutter is designed to provide safe and disc reliable service in operating conditions corresponding with the instructions, but it can present dangers for the user and risks of damage, consequently regular on site inspection is necessary to ensure :

- Perfect technical condition (use for the purpose for which it is intended and taking into account any risks, and correction of any malfunction detrimental to safety).

# Operator's manual - TS 350 E

- Use of a diamond disc for water lubricated cutting of marble, stone, granite, brick and facings (porcelain, glazed tiles, ceramics, etc). The use of any other disc is forbidden (abrasive, saw, etc).
- Competent personnel (qualifications, age, training, education) who have studied the manual in detail before starting work: any fault of an electrical or other nature must be checked by a competent person (electrician, maintenance foreman, authorized dealer, etc).
- That the warnings and instructions marked on the machine are followed (adequate personal protection, correct use, general safety instructions, etc).
- That no modification, transformation or addition is detrimental to safety and that it is carried out without prior authorization from the manufacturer.
- Respect of the maintenance intervals and periodical checks recommended.
- That only genuine spare parts are used for repairs.

## Use

Sawing marble, stone, granite, brick, cement and all facings (porcelain, glazed tiles, ceramics, etc).

## Tools

Water lubricated diamond disc diameter 300 mm - diameter 350xmm (D)- bore 25.4 mm (AL). (Information from your usual supplier).



1. Carborundum disc                      2. Saw blade

Any application not corresponding with the intended use (use of a saw blade, abrasive disc, etc) is prohibited.

## Inspection-Description of the machine

- On receiving the machine check its condition.
- Always keep it perfectly clean.
- Check the supply cable lead periodically.
- Always keep alert when working.
- Check the mounting of the components (abnormal vibration).

### See fig. 1

1. Chassis-tank
2. Leg
3. Head clamping handle
4. Water pump
5. Lifting lever

6. Locking handle
7. Loading leg
8. Drain plug
9. Motor
10. Lack of voltage switch
11. Hood
12. Disc casing
13. Housing cover
14. Movable table
15. Table stop
16. Movable table stop
17. Manufacturer's plate
18. Cutting guide
19. Table locking
20. Carrying handles
21. Transport wheels
22. Water tank
23. Water level

## Handling - transport

Dismantle your machine into two parts.

### Table part (See fig. 3)

- Remove the table by tilting it slightly so as to clear the rear retainer pins

### Blocking table for transportation(See fig. 4)

### Folding the feet (See fig. 5)

### Transport (See fig. 6)

### Loading (See fig. 7)

### Placing on feet (See fig. 8)

## Inspection before starting

Please read the instructions for use prior to operating the machine for the first time.



The use of ear protection is mandatory.



The operator must wear protective clothing appropriate to the work he is doing. We recommend that this includes both eye and ear protection.



The working area must be completely cleared, well lit and all safety hazards removed (no water or dangerous objects in the vicinity).



# Operator's manual - TS 350 E

Any persons not involved in the work should leave the working area.



Use blades suitable for the work to be done (speed, geometry, application, etc.).



## Fitting the disc

Disconnect the machine by unplugging the supply cable.



- Remove the two screw knobs (A) and the protective case (B) (See fig. 9).

**The disc locking nut has a left-hand thread.**



**If the machine is fitted with a brake motor, do not use the quick-tightening nut.**



- Remove the locking flange (See fig. 10).
- Fit the disc (See fig. 11).

**Take care about the direction of rotation which is shown by an arrow on one of the faces.**



**Make sure the contact faces of flanges, of blade and the axle are clean.**

- Tighten the nut (1) and lock (2)
- Refit the protective case (B).
- Tighten the 2 screw knobs (A) (See fig. 13).

## Electrical connection

### Electrical safety

Operate this machine only on a supply equipped with a 30 mA earthed current-limiting circuit-breaker. Otherwise, consult our catalogue for appropriate models.

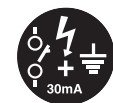

The RCCB must be used correctly, including testing it regularly. For tools supplied with an integral RCCB in the cable or in the mains plug, if the cable or plug has been damaged, repairs must be carried out by the manufacturer, one of his agents or by a qualified repair workshop to avoid any risks resulting from errors.

Make sure that the mains voltage corresponds with that marked on the manufacturer's plate on the machine.



Three-phase motor Make sure that the motor rotates in the same direction as the arrow stamped on the casing: if the motor does not turn in the direction required, swap two of the supply wires.

Use the following types of plug, single phase 2 P + E, or 3xPx+xE / 3xPx+xNx+xE according to the corresponding voltage.

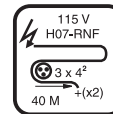
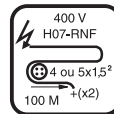
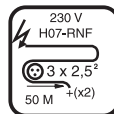
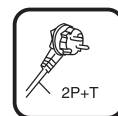

- Extension lead: Cable size sufficient for the electrical power, connection to the mains by a H07 RNF type cable of the following size:

- 3 x 2.5 mm<sup>2</sup> up to 50 m for 230 V
- 4 or 5 x 1.5 mm<sup>2</sup> up to 100 m for 400 V
- 3 x 4 mm<sup>2</sup> up to 40 m for 115 V

## Starting up

**Always pay extreme care and attention to the preparation of the machine before starting up**



**Remove all adjustment tools and wrenches from floor and machine**



**Always keep blade guard in place**



- Fill the water tank ( Level 23. See fig. 1 ).
- The water pump starting is coupled with that of the motor.

**As each machine is fitted with a self priming pump, the water is sprayed onto the disc as soon as the machine starts.**

**Ensure that the water supply is abundant, when cutting wet.**

**The protective case and the motor mounting fitted with a deflector blade provide perfect distribution of the spray.**

- To start the machine press the green button on the switch (optional cut-out switch).



- To stop the machine, press the red button.



**One-phase motor protected by a built-in thermal circuit breaker.**

## Cutting method

### Straight cuts (See fig. 14)

- $\leq 570$  mm : the stop (C) prevents fingers being trapped between the table and the frame (See fig. 15).
- $> 570$  et  $\leq 650$  mm : retract the stop (C) under the table to increase the stroke.

A reversible and removable cutting guide enables  $45^\circ$  to  $90^\circ$  cuts to be made.

This cutting guide is machined in such a way that it can be fitted in several positions in addition to its right angle position from  $0^\circ$  to  $45^\circ$  to the left or to the right.

## Depth of cut adjustment

(See fig. 16)

- Slacken off handle (6).
- Use lever (5) to adjust the cutting height.
- Tighten handle (6).

## Maintenance

### (the motor must be stopped)

- Clean the machine regularly.
- Drain the tank (22) frequently to remove cutting residue, which otherwise could block the pump and cause it to wear out prematurely. (See fig. 17).
- Swill out the tanks (1) and (22) with water.
- Carefully clean the contact faces for the table rollers.

Store in a dry place, not accessible to children. Maintain the tools carefully.



## Fault finding

In the event of faulty operation refer to the tables below to find a solution.

### The machine does not work

Causes	Remedies
Not plugged in properly or cable damaged	Make sure that the supply is correctly plugged in (plug, extension lead, etc) Check the supply cable
No mains voltage	Test or have tested by an electrician (circuit breaker, plug, etc)
Switch defective, motor cable damaged	Have tested by an electrician or contact the service department
Motor faulty (no power, unpleasant smell)	Contact the service department to have the motor replaced

### Difficult starting

Causes	Remedies
Single phase motor starting condenser	Replace the condenser
Three-phase supply not correct (on 2 phases, motor cable faulty)	Have it checked by an electrician or contact the service department

### The pump does not start

Causes	Remedies
The mains lead is not correctly connected or is damaged	Check the mains lead
No voltage in pump circuit or mains supply circuit	Check the pump circuit and mains supply circuit

### The pump does not pump water

Causes	Remedies
An air bubble may have formed inside the pump body	Holding the pump of the outlet pipe remove it from the water and reimmerse it
The turbine is jammed	Unscrew the filter and, using a small screwdriver, remove all dirt from the operating area of the turbine.

## Adjustments

- The machine is set before leaving the factory and no adjustment is necessary.
- However, after shocks, loosening of nuts and bolts, or sharp movements when tilting the head, if necessary adjust the stop screws(D) and check the squareness (for straight cuts) .
- To correct the bevel cutting setting, adjust the stop screw (E) and lock the nut with a lock- nut (See fig. 18).
- $\varnothing 300$  and  $\varnothing 350$  adaptation (See fig. 19)  
A =  $\varnothing 300$   
B =  $\varnothing 350$

## Important advice

- Retighten the nuts and bolts periodically.
- In the event of a long period of use pay special attention to the maintenance and protection of the disc.
- Make sure that sufficient water is sprayed onto the disc.
- Tighten the disc correctly.
- Make sure that the contact faces of the disc, the flanges and the spindle are clean.

**The manufacturer declines all responsibility for loss or damage resulting from misuse or any modification, alteration or powering that does not conform to the manufacturer's original specifications.**





# Operator's manual - TS 350 E

At the work station, the sound pressure level may exceed 85 db (A) In this case individual protection measures must be taken.



## Repairs

Contact your supplier who is entirely at your service to carry out repairs in the shortest time at the best possible price.

## Spare parts

For rapid delivery of spares and in order to avoid any wasted time, it is necessary to remind your supplier of the details shown on the instruction plate on the machine with each order, as well as the reference of the part to be replaced.

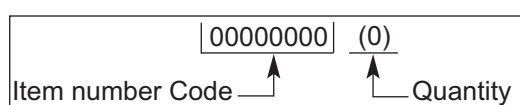

## Scrapping

In the event of deterioration and scrapping of the machine, the following items must be disposed of in accordance with the requirements of the legislation in force.



## Main materials

- Motor : Aluminium (AL), Steel (AC), Copper (CU), Polyamide (PA)
- Machine : Steel sheet (AC), Cast iron (FT)

The instructions for use and spare parts found in this document are for information only and are not binding. As part of our product quality improvement policy, we reserve the right to make any and all technical modifications without prior notice.

## Technical data

Power, kW	2,2 kW (3 CV)	2,9 kW (4 CV)	1,5 kW (2 CV)
Voltage (±5%), V	230 (50 Hz)	400 (50 Hz)	115 (50 Hz)
Current, A	10	11,5	20
Pump	13 W, 230 V	13 W, 230 V	30 W, 115 V
Motor speed, rpm	2800		
Disc speed, rpm	2800		
Electrical protection	IP 54		

Depth of cut (E) at 90°, mm	Ø 350 = 100 Ø 300 = 75
Depth of cut (E) at 45°, mm	Ø 350 = 60 Ø 300 = 40
Length of cut (L), mm	E = 15 - 650 E = 50 - 600
Useable width (to the right) (l), mm	Ø 350 = 310 Ø 300 = 300
Dimensions (mm) l x w x h	1130 x 630 x 1300 (with legs) 1130 x 630 x 700 (bench)
Weight (depending on model), kg	±92      Chassis 56 Head 36
Disc cooling	Water spray into the disc casing
Minimum tank capacity, l	40
Water pump	13 W - débit : 8 l/mn.
Electricity supply	230 V (H07-RNF 3 x 1,52 - Lg 3 m) 400 V (H07-RNF 4 ou 5 x 1,52 - Lg 3 m) 115 V (H07-RNF 3 x 2,52 - Lg 3 m)

<b>Noise emissions (see note 1)</b>	
Sound power level, measured dB(A)	111
Sound power level, guaranteed dB(A)	112
<b>Sound levels (see note 2)</b>	
Sound pressure level at the operators ear, dB(A)	106
<b>Vibration levels, a<sub>hv</sub> (see note 3)</b>	
Handle, m/s <sup>2</sup>	2,7

Note 1: Noise emissions in the environment measured as sound power ( $L_{WA}$ ) in conformity with EC directive 2000/14/EC. The difference between guaranteed and measured sound power is that the guaranteed sound power also includes dispersion in the measurement result and the variations between different machines of the same model according to Directive 2000/14/EC.

Note 2: Noise pressure level according to EN 12418. Reported data for noise pressure level has a typical statistical dispersion (standard deviation) of 1.0 dB(A).

Note 3: Vibration level according to EN 12418. Reported data for vibration level has a typical statistical dispersion (standard deviation) of 1 m/s<sup>2</sup>.

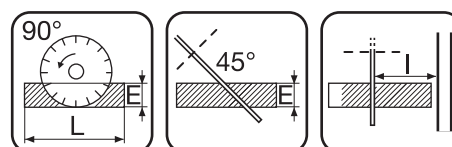

## EC declaration of conformity

**Husqvarna AB**, SE-433 81 Göteborg, Sweden, tel: +46-31-949000, declares under sole responsibility that the tile saw **Husqvarna TS 350 E** dating from 2010 serial numbers and onwards (the year is clearly stated on the rating plate, followed by the serial number), complies with the requirements of the COUNCIL'S DIRECTIVE:

- of May 17, 2006 "relating to machinery" 2006/42/EC
- of December 15, 2004 "relating to electromagnetic compatibility" 2004/108/EC.
- of December 12, 2006 "relating to electrical equipment" 2006/95/EC.
- of May 8, 2000 "relating to the noise emissions in the environment" 2000/14/EC. Conformity assessment according to Annex V.
- of June 08, 2011 on the 'restriction of use of certain hazardous substances' 2011/65/EU.

The following standards have been applied: EN ISO 12100:2010, EN 55014-1:2006, EN 55014-2/A1:2001, EN 61000-3-2:2006, EN 61000-3-11:2000, EN 12418+A1:2009.

Gothenburg 12 April 2015



Helena Grubb  
Vice President, Construction Equipment Husqvarna AB  
(Authorized representative for Husqvarna AB and responsible for technical documentation.)

The Equipment fulfills the requirements in EN61000-3-11 and is subject for conditional connection to the mains. It may be connected in consultation with the supply authority. The equipment will only be connected to the mains supply with impedance lower than 0,49 Ohm. The system impedance at the interface point may be obtained from the supply authority.

If the mains supply has higher system impedance, short voltage dips may appear when the equipment is started. This may influence the operation of other apparatuses, e.g flickering lights.

230V

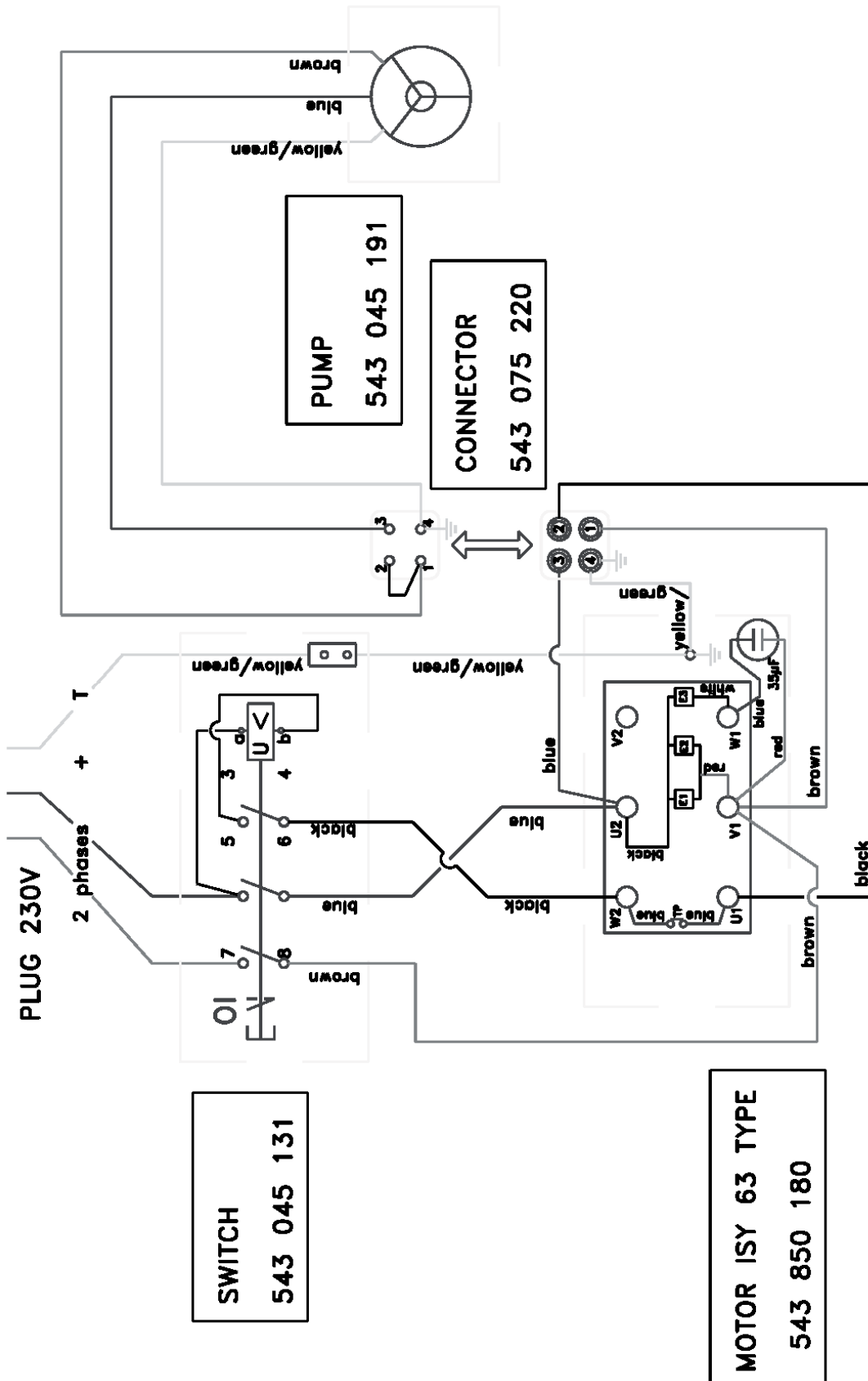



## WARRANTY CONDITIONS

### 1. PERIOD

The warranty is acknowledged as of the date of purchase (date of the invoice of the distributor) and is valid for a period of 12 months.

### 2. WARRANTY

The warranty is limited to the free of charge replacement of parts recognised as defective by Husqvarna (excluding wear components and consumables) providing the repair is made within after-sales service of Husqvarna or a recognised Husqvarna repair centre.

The manufacturer is not responsible for any direct or indirect, material or immaterial, damages caused to persons or things by failure of the machine or the non operation of the machine.

### 3. WARRANTY CONDITIONS

To benefit the warranty, it is necessary to return the joined warranty certificate, duly completed, to Husqvarna within eight days of the purchase.

In case of failure of the machine during the warranty period, our after-sales services will inform you of the appropriate and most effective method of dealing with your claim and advise you if necessary of your nearest approved service centre.

As an alternative, you may return, at your cost, the machine together with a written description of the problem and damages with a copy of the invoice directly to our after sales department where upon a full investigation will be instigated without delay.

### 4. EXCLUSIONS

Warranty will not be applied for damages or failures caused by :

- incorrect use, error in transportation, handling or maintenance,
- use of incorrect fuel or lubricants not advised by Husqvarna,
- use of non-genuine parts or accessories,
- repairs made by non approved service centres,
- use of incorrect specifications of cutting tools.(We suggest the use of Husqvarna tools).

The goods are returned at the sole responsibility of the Buyer who must appeal against the transporter in the usual manner without delay.







[www.husqvarnacp.com](http://www.husqvarnacp.com)

**Original instructions**

1157638-26



2015-05-13