



Husqvarna®



Operator's manual

Pre-separator

C 5500



Please read the operator's manual carefully and make sure you understand the instructions before using the machine.

US

Introduction

Dear Customer,

Thank you for choosing Husqvarna Construction Products as your supplier.

We hope that the model C 5500 pre-separator will be to your satisfaction and meet your expectations.

Husqvarna has been manufacturing professional dust extractors since 1967 and has over the years acquired a genuine technical knowledge in this area.

Please feel free to browse information about our product programme on our web site <http://www.hcp.com>

Notice!

These instructions are only for pre-separators C 5500.

Pre-separators C 5500 can only be used with dry, non-explosive materials.

Husqvarna Construction Products will not be held responsible if the pre-separator is used for other applications or been used in ways other than those outlined in this instruction manual.

Before using the machine, please safety regulations carefully.

Read the complete instruction manual before using the pre-separator.

All spare parts used for pre-separator types C 5500 must be those specified by Husqvarna Construction Products.

Unpacking

When unpacking the machine, please check for damage and that the following accessories are included:

- The hose with end fittings

If any of the above-mentioned parts are missing, please contact your local distributor or our sales representative.

Assemble the front wheels by using the bolt, washer and nut that are included in the package.

Product overview C 5500

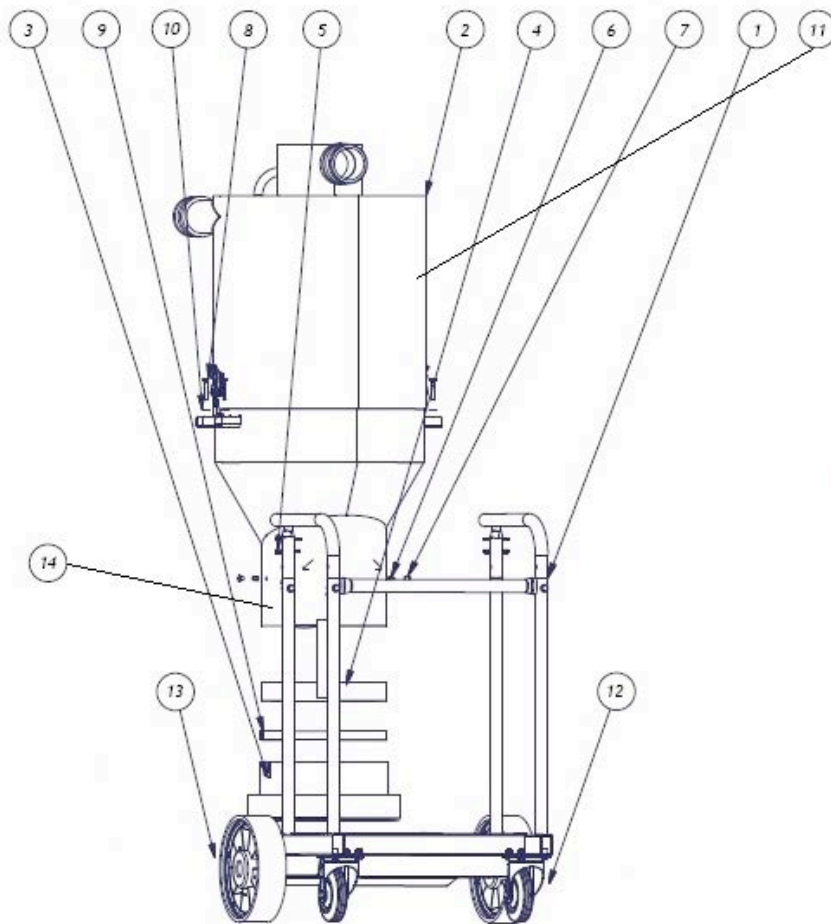

accessories

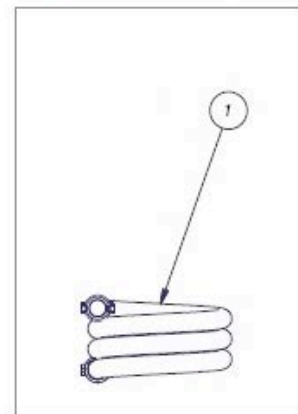

POS.	DESCRIPTION
1	WAGON KIT (ex. C 5500)
2	UPPER TANK KIT (ex. C 5500)
3	LONGOPAC HOLDER KIT
4	ANTI-SKID KIT
5	N/A
6	M6X8 SCREW FZB LOW HEAD
7	MKSM6 NUT
8	EXCENTRIC LOCK KIT
9	BELT KIT
10	LOWER TANK KIT (ex. C 5500)
11	TANK CAMLOK KIT (ex. C 5500)
12	SWIVEL WHEELS 2 PCS KIT (ex. C 5500)
13	FRONT WHEELS 2 PCS KIT (ex. C 5500)
14	FLAP COMPLETE DIMENSION 215 mm (2503)
Accessories	
1	PU76/10 ANTISTATIC HOSE 2xCAMLOK FEMALE

Safety Instructions

Handling

Warning

- Make sure that you read and understand the instructions for the main product to ensure that you know what personal equipment to wear, what safety equipment to use and how to work in a safe mode.

Warning

- Make sure the assembly area is firm, so the vacuum cleaner does not tip over. Risk of personal and material injury.

Warning

- Risk of pinching when handling the toggle fastener.

Warning

- The machine must not be used in environments where explosive gases may be present. Serious risk of explosion.

Service

Warning

- Make sure the cord is unplugged when performing service or maintenance to the product.

Warning

- Dust can be spread when cleaning the device that can be dangerous to health. Accordingly, the user should wear protective glasses, protective gloves, and a breathing mask conforming to protection class FFP3

Warning

- Do not puncture the longopac bag. Risk of dust dispersion.

Function

The machine is intended for pre-separating dry, not combustible dust.

The pre-separator must be attached to a vacuum cleaner with right capacity. When the vacuum cleaner is started, the dust-laden air is then sucked through the inlet valve at high speed via the suction hose. The air is slowed down by the cyclone and coarse dust particles are separated out, partly by centrifugal force and partly by gravity. Air and finer particles then lift through the tank and through the hoses attached to the vacuum cleaner.

The separated dust accumulates in the cyclone until the vacuum cleaner is switched off, when it drops through the bottom flap into the plastic bag.

C5500 is equipped with an earth cable. Attach this to the vacuum cleaner to avoid static discharges from the pre-separator.

Service

When cleaning and servicing the machine, disconnect the machine from the vacuum cleaner.

- Avoid cleaning with high a pressure cleaner. If this is necessary, do not direct at the openings on the machine, especially the opening for the cooling air.
- Before moving the machine from the work area, the machine must be cleaned. Furthermore, the inlet must be locked using the expanding plug attached.
- All other equipment must be regarded as contaminated and be treated thereafter.
- If possible, use a special suitable room.
- Proper personnel protective equipment must be used.
- After service, all parts which are contaminated must be correctly disposed of in plastic bags according to all regulations.
- If the vacuum cleaner has to be used for other purposes, it is extremely important that the vacuum cleaner is cleaned, to avoid the spread of hazardous dust.

Accessories

Part.no.	Description	No/machine
590426101	Longopac (4-pack)	1 pcs

Warranty

All Vacuum cleaners and accessories have a 12-month factory warranty for material and manufacturing defects.

Do not attempt to repair the suction apparatus without the consent of the manufacturer.

The warranty does not cover defects which are the result of normal wear and tear, negligence, defective use, unauthorised repair or the suction apparatus being connected to the incorrect voltage. In the event of any complaint, the suction apparatus or an agreed part of it must be returned to us or our authorised representative for warranty examination and for any warranty repair or replacement.

Problem solving

The pre-separator C 5500 are designed and manufactured for a severe environments and tasks, but the user must note that the machine components must be protected from knocks and blows. Sealing connections are carefully chosen for the environment of the operator. Therefore, the machine must be handled with care if it is to work for many years.

Problem	Cause	Procedure
Poor suction	Damage to the hose	Change hose
	Top cover loose	Adjust
	Dirt in the flap	Clean the flap. <i>Use protective equipment</i>
	Sealing defective	Change current seal

KEEP THESE INSTRUCTIONS!

TECHNICAL DATA

C 5500	
Hose	10 m x Ø 76 mm
Inlet	Ø 76 mm Camlock
Outlet	Ø 76 mm Camlock
Plastic bag	Longopac
Dimensions LxBxH	580x720x1590 mm
Weight	46 kg / 101 lbs
Volume	100 l / 26 gal



www.husqvarnacp.com

Original instructions

1158777-26

2017-04-27