



 **Husqvarna**[®]



LT 8005

Contents

| | | | |
|-------------------|---|---|----|
| Introduction..... | 2 | Transportation, storage and disposal..... | 12 |
| Safety..... | 4 | Technical data..... | 13 |
| Operation..... | 7 | EC Declaration of Conformity..... | 16 |
| Maintenance..... | 9 | | |

Introduction

Product description

The product is a rammer for compaction of granular soil, fine-grained soil and soil that has high contents of clay.

pipes or other small spaces. Examples of such work are house foundations and parking lots. Do not use the product for other tasks.

Intended use

The product is for professional operation only. The product is used for compaction in trenches, around

Product overview

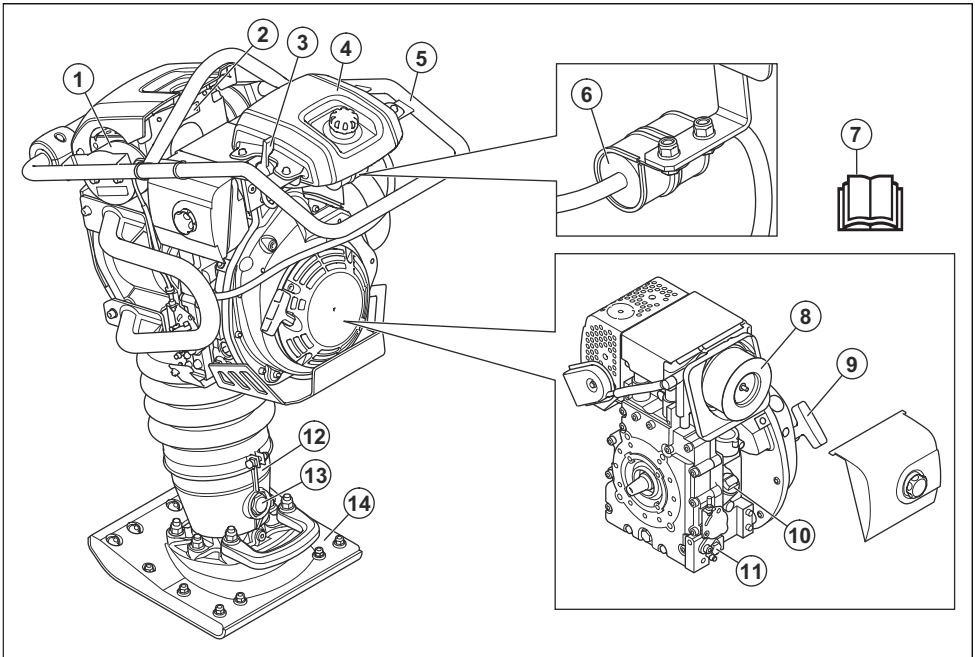

- | | |
|----------------------------|---|
| 1. Vibration damping units | 8. Air filter |
| 2. Type plate | 9. Starter rope handle |
| 3. Throttle control | 10. Oil tank / dipstick |
| 4. Fuel tank | 11. Drain plug for engine oil |
| 5. Handle | 12. Rammer leg |
| 6. Fuel filter | 13. Sight glass for the oil in the spring-loaded rammer leg |
| 7. Operator's manual | |

14. Rammer shoe

Throttle control

The throttle control has 3 available positions:



Operation mode position (A)



Start position/idle speed position (B)

n/min



Stop position (C)

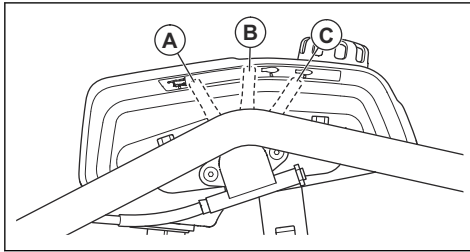

Symbols on the product



WARNING: This product can be dangerous and cause serious injury or death to the operator or others. Be careful and use the product correctly.



Read the manual carefully and make sure that you understand the instructions before you use the product.



Use hearing protection.



Use boots with steel toe-cap and non-slip sole.



Hot surface.



The spring can eject and cause injury.



Ultra-low-sulfur diesel fuel only.



Lift the product at this part of the safety frame.



Noise emission to the environment as referred to in the EC directive. The emission of the product is specified in *Technical data* on page 13 and on the label.



This product is in compliance with applicable EC directives.

Note: Other symbols/decals on the product refer to special certification requirements for some markets.

Type plate

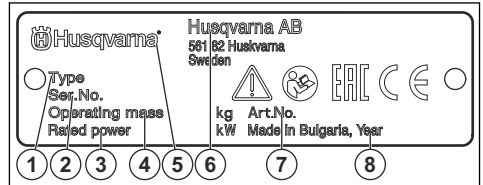

1. Product type
2. Serial number with production date, year, week and sequence number
3. Rated power
4. Product weight
5. Brand
6. Manufacturer and manufacturer address
7. Product number
8. Production year

Euro V Emissions



WARNING: Tampering with the engine voids the EU type-approval of this product.

Product liability

As referred to in the product liability laws, we are not liable for damages that our product causes if:

- the product is incorrectly repaired.
- the product is repaired with parts that are not from the manufacturer or not approved by the manufacturer.

- the product has an accessory that is not from the manufacturer or not approved by the manufacturer.

- the product is not repaired at an approved service center or by an approved authority.

Safety

Safety definitions

Warnings, cautions and notes are used to point out specially important parts of the manual.



WARNING: Used if there is a risk of injury or death for the operator or bystanders if the instructions in the manual are not obeyed.



CAUTION: Used if there is a risk of damage to the product, other materials or the adjacent area if the instructions in the manual are not obeyed.

Note: Used to give more information that is necessary in a given situation.

General safety instructions



WARNING: Read the warning instructions that follow before you use the product.

- This product is a dangerous tool if you are not careful or if you use the product incorrectly. This product can cause serious injury or death to the operator or others. Before you use the product, you must read and understand the contents of this operator's manual.
- Save all warnings and instructions.
- Comply with all applicable laws and regulations.
- The operator and the employer of the operator must know and prevent the risks during operation of the product.
- Do not let a person operate the product unless they read and understand the contents of the operator's manual.
- Do not operate the product unless you receive training before use. Make sure that all operators receive training.
- Only let approved persons operate the product.
- The operator is responsible for accidents that occur to other persons or their property.
- Do not use the product if you are tired, ill, or under the influence of alcohol, drugs or medicine.
- Always be careful and use your common sense.
- This product produces an electromagnetic field during operation. This field can under some circumstances interfere with active or passive medical implants. To decrease the risk of serious injury or death, we recommend persons with medical implants to speak to their physician and the medical implant manufacturer before operating this product.

- Keep the product clean. Make sure that you can clearly read signs and decals.
- Do not use the product if it is defective.
- Do not change this product.
- Do not operate the product if it is possible that it is changed by other persons.

Safety instructions for operation



WARNING: Read the warning instructions that follow before you use the product.

- Make sure that you know how to stop the engine quickly in an emergency.
- The operator must have the physical strength that is necessary to operate the product safely.
- Do not operate the product without all protective covers installed.
- Use personal protective equipment. Refer to *Personal protective equipment on page 6*.
- Make sure that only approved persons are in the work area.
- Keep the work area clean and bright.
- Make sure that you are in a safe and stable position during operation.
- Make sure that there is no grease or oil on the handles, the safety frame and other surfaces on the product. Slippery surfaces can cause the product to fall and there is a risk of injury and damage to the product.
- Do not use the product in areas where fire or explosions can occur.
- The product can cause objects to eject at high speed. Make sure that all persons in the work area use approved personal protective equipment. Remove loose objects from the work area.
- Before you go away from the product, stop the engine and make sure that there is no risk of accidental start.
- Make sure that clothes, long hair and jewelry do not get caught in moving parts.
- Do not hit the product.
- Always operate the product from behind with your two hands on the handle. Do not touch the rammer shoe when the product is on.
- Do not operate the product near electrical cables. The product does not have electrical insulation and injury or death can occur.
- Before you operate the product, find out if there are hidden wires, cables and pipes in the work area. If the product hits a hidden object, stop the engine immediately and examine the product and the object.

Do not start to operate the product again until you know that it is safe to continue.

- Put the product in an upright position before you start it.
- Do not sit on the product.
- Keep your feet away from the rammer shoe.
- Do not operate the product with your leg on the handle.
- Do not operate the product on solid rock, hard concrete or other hard surfaces. There is a risk of injury and damage to the product.
- Do not operate the product on a slope.
- When you operate the product in a trench or other small space, make sure that the rammer shoe can move freely. If the space is too small for the rammer shoe, there is a risk of damage to the product. There is also a risk of injury from sudden movements in the product.
- If the product falls on its side during operation, stop the engine before you lift the product to upright position.

Vibration safety



WARNING: Read the warning instructions that follow before you use the product.

- During operation of the product, vibrations go from the product to the operator. Regular and frequent operation of the product can cause or increase the degree of injuries to the operator. Injuries can occur in fingers, hands, wrists, arms, shoulders, and/or nerves and blood supply or other body parts. The injuries can be debilitating and/or permanent, and can increase gradually during weeks, months or years. Possible injuries include damage to the blood circulation system, the nervous system, joints, and other body structures.
- Symptoms can occur during operation of the product or at other times. If you have symptoms and continue to operate the product, the symptoms can increase or become permanent. If these or other symptoms occur, get medical aid:
 - Numbness, loss of feeling, tingling, pricking, pain, burning, throbbing, stiffness, clumsiness, loss of strength, changes in skin color or condition.
- Symptoms can increase in cold temperatures. Use warm clothing and keep your hands warm and dry when you operate the product in cold environments.
- Do maintenance on and operate the product as given in the operator's manual, to keep a correct vibration level.
- The product has a vibration damping system that decreases the vibrations from the handles to the operator. Let the product do the work. Do not push the product with force. Hold the product at the handles lightly, but make sure that you control the

product and operate it safely. Do not push the handles into the end stops more than necessary.

- Keep your hands on the handle or handles only. Keep all other body parts away from the product.
- Stop the product immediately if strong vibrations suddenly occurs. Do not continue the operation before the cause of the increased vibrations is removed.

Dust safety



WARNING: Read the warning instructions that follow before you use the product.

- Operation of the product can cause dust in the air. Dust can cause serious injury and permanent health problems. These are examples of such health problems:
 - The fatal lung diseases chronic bronchitis, silicosis and pulmonary fibrosis
 - Cancer
 - Birth defects
 - Skin inflammation
- Use correct equipment to decrease the quantity of dust and fumes in the air and to decrease dust on work equipment, surfaces, clothing and body parts. Examples of controls are dust collection systems and water sprays to bind dust. Decrease dust at the source where possible. Make sure that the equipment is correctly installed and used and that regular maintenance is done.
- Use approved respiratory protection. Make sure that the respiratory protection is applicable for the dangerous materials in the work area.
- Make sure that the airflow is sufficient in the work area.
- If it is possible, point the exhaust of the product where it cannot cause dust to go into the air.

Exhaust fumes safety



WARNING: Read the warning instructions that follow before you use the product.

- The exhaust fumes from the engine contain carbon monoxide which is an odourless, poisonous and very dangerous gas. To breathe carbon monoxide can cause death. Because carbon monoxide is odourless and cannot be seen, it is not possible to sense it. A symptom of carbon monoxide poisoning is dizziness, but it is possible that a person becomes unconscious without warning if the quantity or concentration of carbon monoxide is sufficient.
- Exhaust fumes that you can see or smell also contain carbon monoxide.
- Do not use a combustion engine product indoors or in areas that do not have sufficient airflow.

- Do not breathe the exhaust fumes.
- Make sure that the airflow in the work area is sufficient. This is very important when you operate the product in trenches or other small work areas where exhaust fumes can easily collect.

Noise safety



WARNING: Read the warning instructions that follow before you use the product.

- High noise levels and long-term exposure to noise can cause noise-induced hearing loss.
- To keep the noise level to a minimum, do maintenance on and operate the product as given in the operator's manual.
- Examine the muffler for damages and defects. Make sure that the muffler is correctly attached to the product.
- Use approved hearing protection while you operate the product.
- Listen for warning signals and voices when you use hearing protection. Remove the hearing protection when the product is stopped, unless hearing protection is necessary for the noise level in the work area.

Personal protective equipment



WARNING: Read the warning instructions that follow before you use the product.

- Always use approved personal protective equipment when you operate the product. Personal protective equipment cannot fully prevent injury but it decreases the degree of injury if an accident does occur. Let your dealer help you select the correct personal protective equipment.
- Regularly do a check of the condition of the personal protective equipment.
- Use an approved protective helmet.
- Use approved hearing protection.
- Use approved respiratory protection.
- Use approved eye protection with side protection.
- Use protective gloves.
- Use boots with steel toe-cap and non-slip sole.
- Use approved work clothing or equivalent close-fitting clothing that has long sleeves and long legs.

Fire extinguisher

- Keep a fire extinguisher near during operation.
- Use a powder fire extinguisher of "ABE" class or a carbon dioxide fire extinguisher of "BE" type.

Safety devices on the product



WARNING: Read the warning instructions that follow before you use the product.

- Do not use a product with defective safety devices.
- Do a check of the safety devices regularly. If the safety devices are defective, speak to your Husqvarna service agent.

Safety frame

The safety frame prevents damage to the product if it falls. The handle and the lifting point are parts of the safety frame.

To do a check of the safety frame

- Make sure that there are no cracks or other damages on the safety frame.
- Make sure that the safety frame is correctly installed on the product.

Vibration damping units

The vibration damping units decrease vibration in the product. The vibration damping units decrease harmful vibrations to prevent injury to the operator and damage to the product.

To do a check of the vibration damping system

1. Make sure that there are no cracks or deformation on the vibration damping units.
2. Make sure that the vibration damping units are correctly attached to the engine unit and handle unit.

Refer to *Product overview on page 2* for information about where the vibration damping system is on your product.

To do a check of the stop function

1. Start the product. Refer to *To start the product on page 8*.
2. Set the throttle control in the stop position.

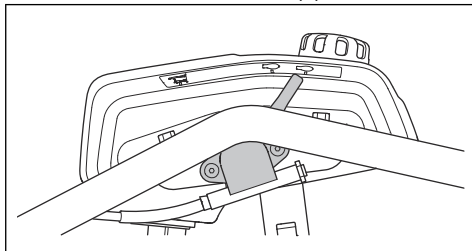

3. If the engine does not stop, let an approved service center do servicing on the product.

Fuel safety



WARNING: Read the warning instructions that follow before you use the product.

- Fuel is flammable and the fumes are explosive. Be careful with fuel to prevent injury, fire and explosion.
- Do not breathe in the fuel fumes. The fuel fumes are poisonous and can cause injury. Make sure that the airflow is sufficient.
- Do not remove the fuel tank cap or fill the fuel tank when the engine is on.
- Let the engine become cool before you refuel.
- Do not fill fuel in an indoor area. Not sufficient airflow can cause injury or death because of asphyxiation or carbon monoxide.
- Do not smoke near the fuel or the engine.
- Do not put hot objects near the fuel or the engine.
- Do not fill fuel near sparks or flames.
- Before you refuel, open the fuel tank cap slowly and release the pressure carefully.
- Fuel on your skin can cause injury. If you get fuel on your skin, use soap and water to remove the fuel.
- If you spill fuel on your clothing, change clothing immediately.
- Do not fill the fuel tank fully. Heat causes the fuel to expand. Keep a space at the top of the fuel tank.
- Tighten the fuel tank cap fully. If the fuel tank cap is not tightened, there is a risk of fire.
- Before you start the product, move the product to a minimum of 3 m/10 ft from where you refueled.
- Do not start the product if there is fuel or engine oil on the product. Remove the unwanted fuel and engine oil and let the product dry before you start the engine.
- Examine the engine for leaks regularly. If there are leaks in the fuel system, do not start the engine until the leaks are repaired.
- Do not use your fingers to examine the engine for leaks.
- Keep fuel in approved containers only.

- When the product and fuel is in storage, make sure that fuel and fuel fumes cannot cause damage.
- Drain the fuel in an approved container outdoors and away from sparks and flames.

Safety instructions for maintenance



WARNING: Read the warning instructions that follow before you use the product.

- If the maintenance is not done correctly and regularly, the risk of injury and damage to the product increases.
- Stop the engine and let the product become cool before you do the maintenance.
- Clean the product to remove dangerous material before you do the maintenance.
- Disconnect the spark plug cap before you do the maintenance.
- The exhaust fumes from the engine are hot and can contain sparks. Do not operate the product in indoor areas or near flammable material.
- Do not change the product. Modifications that are not approved by the manufacturer, can cause serious injury or death.
- Always use original accessories and spare parts. Accessories and spare parts that are not approved by the manufacturer, can cause serious injury or death.
- Replace damaged, worn or broken parts.
- Only do the maintenance as given in this operator's manual. Let an approved service center do all other servicing.
- Remove all tools from the product before you start the engine after maintenance. Loose tools or tools attached to rotating parts can eject and cause injury.
- After maintenance, do a check of the vibration level in the product. If it is not correct, speak to an approved service center.
- Let an approved service center do servicing on the product regularly.

Operation

Introduction



WARNING: Read and understand the safety chapter before you use the product.

To do before you operate the product

- Read the operator's manual carefully and make sure that you understand the instructions.
- Read the engine manual that is supplied by the engine manufacturer.

- Do the daily maintenance. Refer to *Maintenance schedule on page 9*.

To start the product

1. Set the throttle control in the start position.

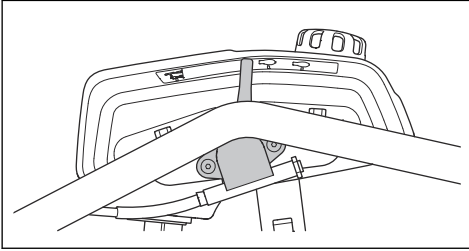

2. Pull the starter rope handle slowly until you feel resistance.

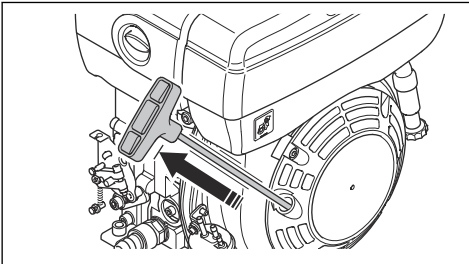

3. Release the starter rope handle to let the starter rope go back.
4. Pull the starter rope handle until the engine starts.
5. Let the engine operate at idle speed for 2–3 minutes before you apply full throttle.

To do if the engine does not start

If the engine does not start and white smoke shows, do the procedure that follows.

1. Set the throttle control to the stop position.
2. Slowly pull and release the starter rope handle 5 times.
3. Do the start procedure again.

To operate the product

1. Set the throttle control in the operation position.

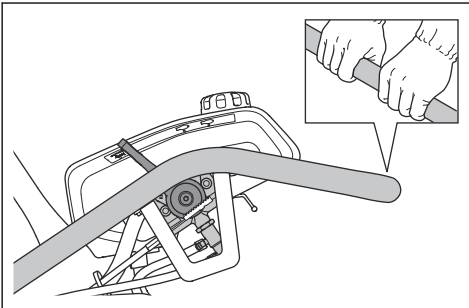

2. Hold the handle and move the product in the necessary direction.



CAUTION: Do not push the product down. Too much pressure can cause unsatisfactory result.

3. Make sure that the rammer shoe is parallel to the ground during the operation.

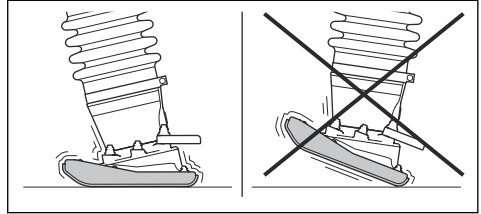

To stop the product

1. Set the throttle control in the idle speed position. Let the engine operate at idle speed for 2–3 minutes.

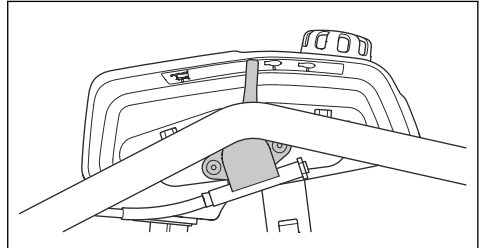

2. Set the throttle control in the stop position.

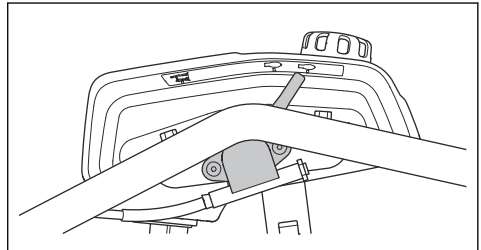

Maintenance

Introduction



WARNING: Read and understand the safety chapter before you do maintenance on the product.

Maintenance schedule

* = General maintenance done by the operator. The instructions are not given in this operator's manual.

X = The instructions are given in this operator's manual.

O = Refer to the engine manual for instructions.

| General product maintenance | Before use, each 10 h | After the first 20 h | Weekly, each 100 h | Yearly, each 500 h |
|--|-----------------------|----------------------|--------------------|--------------------|
| Make sure that there are no fuel or oil leaks. | * | | | |
| Clean the product. | X | | | |
| Make sure that nuts and screws are tightened. | * | | | |
| Examine the throttle control for damage. | * | | | |
| Make sure that the throttle control can move smoothly. | * | | | |
| Lubricate the throttle control and the engine throttle wire. | | | X | |
| Do a check of the oil level in the rammer leg. | X | X | | X |
| Replace the oil in the rammer leg. | | X | | X |
| Tighten the bolts on the rammer shoe. | | X | | |

| Engine maintenance | Before use, each 10 h | After the first 20 h | Weekly, each 100 h | Yearly, each 500 h |
|--|-----------------------|----------------------|--------------------|--------------------|
| Do a check of the fuel level and the engine oil level. | X | | | |
| Clean or replace the air filter. | X | | | |
| Clean and examine the cooling fins of the engine. | O | | | O |
| Replace the engine oil. | | X | | X |
| Replace the air filter. | | X | X | X |
| Adjust the engine valve clearance. | | O | | |
| Adjust the valve head clearance for the air intake and the exhaust valves. | | | | O |
| Drain and clean the fuel tank. | | | | O |
| Drain water from the fuel system. | | | | O |
| Replace the fuel filter. | | | | O |
| Clean the oil filter. | | O | | O |
| Do a check of the fuel injection pump. | | | | O |
| Do a check of the fuel injection nozzle. | | | | O |

| Engine maintenance | Before use, each 10 h | After the first 20 h | Weekly, each 100 h | Yearly, each 500 h |
|---------------------------|-----------------------|----------------------|--------------------|--------------------|
| Replace the piston rings. | | | | ○ |

To clean the product



CAUTION: Before you clean the product, attach a plastic bag tightly around the fuel tank cap. This is to make sure that water does not go into the venthole in the fuel tank cap.

- Use running water from a hose or a high-pressure washer to clean the product.



CAUTION: Do not point the water directly at the fuel tank cap, electrical components or the engine.

- Use solvent to clean mechanical parts.
- Remove grease and oil from the handle.

To do a general inspection

- Make sure that all nuts and screws on the product are tightened correctly.

To tighten the bolts on the rammer shoe

- Tighten the bolts on the rammer shoe with a wrench.

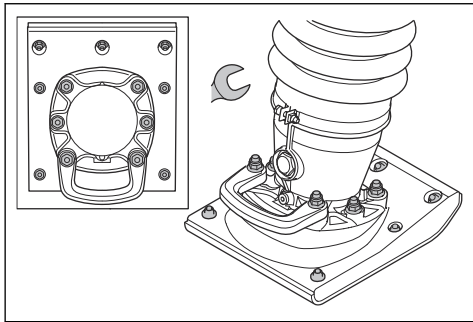

Note: A 280 mm/11 in. wide rammer shoe has 13 bolts. A 330 mm/13 in. wide rammer shoe has 19 bolts.

To do a check of the engine oil level

1. Put the product in an upright position.
2. Remove the oil tank cap and dipstick.

3. Clean the oil from the dipstick.

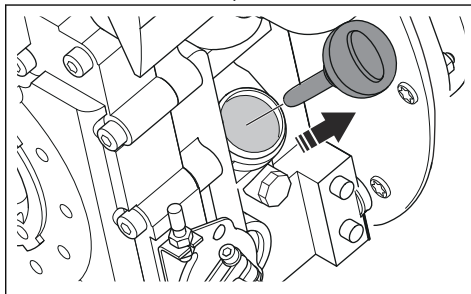

4. Put the dipstick back fully into the oil tank.
5. Remove the dipstick.
6. Examine the oil level on the dipstick.
7. If the oil level is low, fill with engine oil and do a check of the oil level again. Refer to *Technical data on page 13* for the correct type of oil.

To replace the engine oil

If the engine is cold, start the engine for 1–2 minutes before you drain the engine oil. This makes the engine oil warm and easier to drain.



WARNING: Engine oil is very hot directly after the engine stops. Let the engine become cool before you drain the engine oil. If you spill engine oil on your skin, clean with soap and water.

1. Put a container below the drain plug for the engine oil.
2. Remove the oil drain plug.

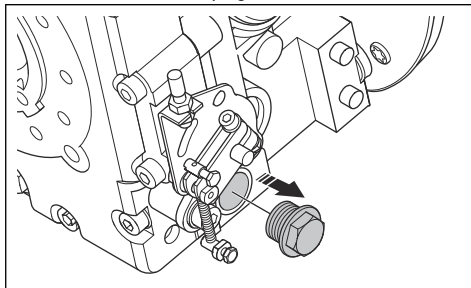

3. Connect a hose to the oil drain hole.
4. Tilt the product and let the oil run through the hose and into the container.
5. Install the oil drain plug and tighten it.

6. Fill with new engine oil. Refer to *Technical data on page 13* for the correct type of oil.
7. Do a check of the engine oil level.

To replace the oil in the rammer leg

1. Put a container below the oil drain plug.
2. Remove the oil drain plug.

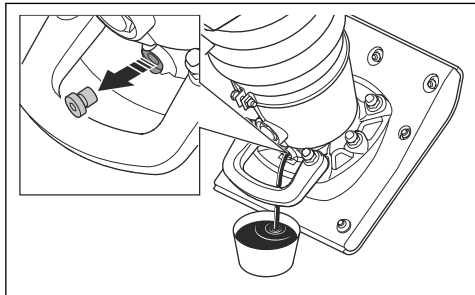

3. Let the oil run out into the container.
4. Install the oil drain plug and tighten it. Make sure that the sealing washer is not damaged.
5. Remove the sight glass.

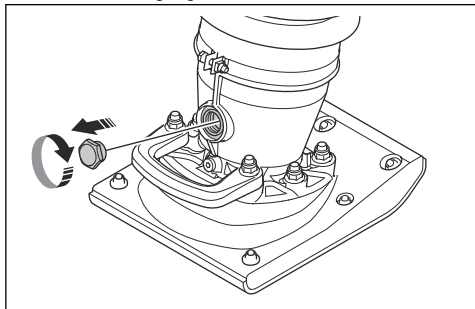

6. Fill with new oil through the hole for the sight glass. Refer to *Technical data on page 13* for the correct type of oil.
7. Install the sight glass and tighten it fully.
8. Do a check of the oil level.

To do a check of the oil level in the rammer leg

1. Put the product in upright position.

2. Look at the sight glass (A). The oil level is correct when it is at the middle of the sight glass.

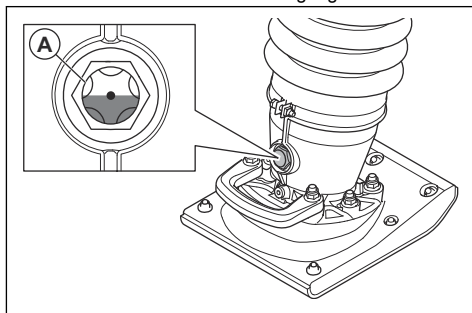

To clean or replace the air filter



WARNING: Use approved respiratory protection when you clean or replace the air filter. Discard used air filters correctly. The dust in the air filter is dangerous to your health.



WARNING: Do not clean the air filter with compressed air. This causes damage to the air filter and the risk increases that you breathe the dangerous dust.

1. Turn the knob on the air filter cover and remove the air filter cover.

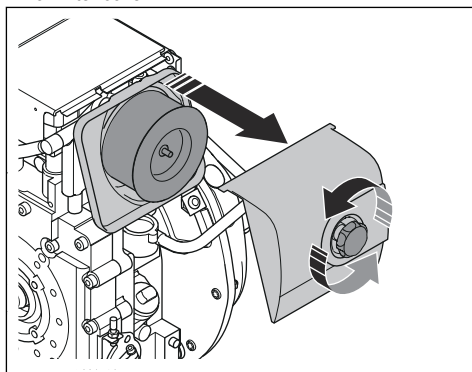

2. Remove the air filter.
3. Clean the air filter housing with a brush.
4. Tap the air filter against a hard surface or use a vacuum cleaner to remove the particles.



CAUTION: Do not let the nozzle of the vacuum cleaner touch the surface of the paper filter element. Keep a small distance. The sensitive surface of the paper filter element becomes damaged if objects touch it.

5. Examine the air filter for damage.
6. Discard the air filter if it is damaged.



CAUTION: Always replace a damaged air filter, or the dust will go into the engine and cause engine damage.

7. Put the clean air filter or a new air filter into the air filter housing.
8. Install the air filter cover.

Transportation, storage and disposal

Transportation



WARNING: Be careful during transportation. The product is heavy and can cause injury or damage if it falls or moves during transportation.

Transport wheels let you move the product manually for shorter distances. For longer distances, lift the product to move it or put the product on a vehicle.



CAUTION: Do not tow the product behind a vehicle.

To move the product on the transport wheels

1. Set the throttle control in the stop position.

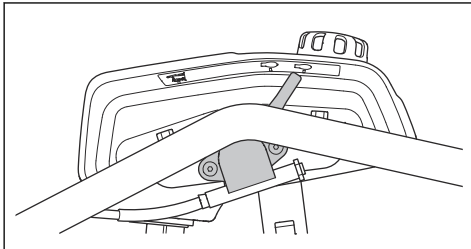

2. Tilt the product forward until the wheels on the handle are on the ground.
3. Lift the product at the lift handle and move it forward and rearward on the wheels.

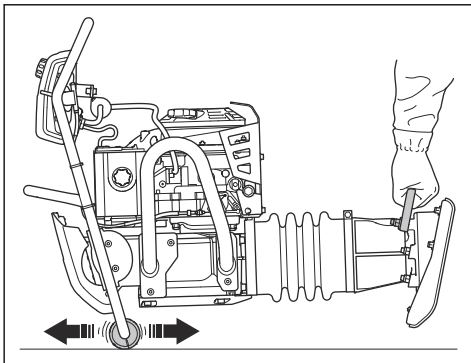

To lift the product



WARNING: Make sure that the lifting equipment has the correct specification to lift the product safely. The type plate on the product shows the product weight.

- Attach the lifting equipment at the lifting point of the safety frame. A label on the product identifies the correct position.

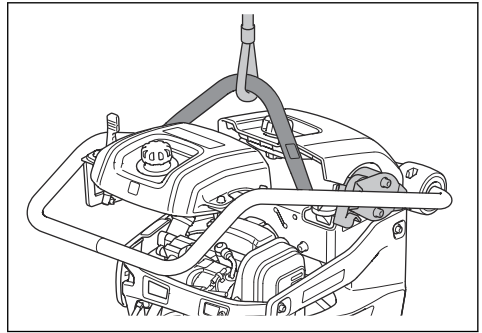

WARNING: Do not lift a damaged product. Make sure that the safety frame and the vibration damping units are correctly installed and not damaged.



WARNING: Do not walk or stay below or near a lifted product.

To safety the product to a transportation vehicle with tie-down straps

1. Set the throttle control in the stop position.

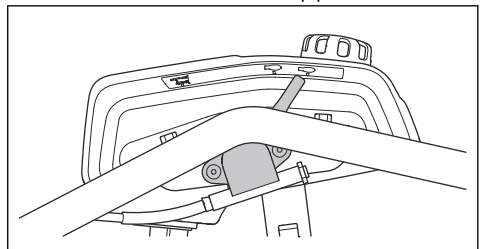

2. Tilt the product forward until the wheels on the handle are on the ground.
3. Attach a strap to the lifting eye and to the vehicle.
4. Attach a strap to the lift handle and to the vehicle.

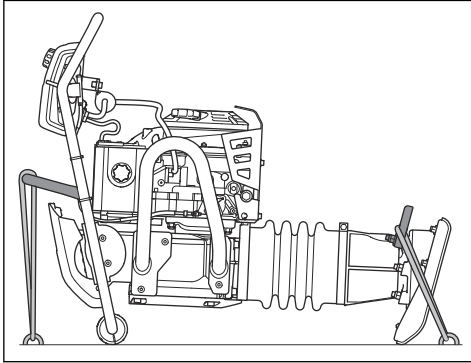

Storage

- Remove all fuel from the fuel tank before you put the product in storage for a long period of time. Discard the fuel at an applicable disposal location.

- Clean the product before storage. Remove clay and sand from the rammer shoe. Remove oil and dust from the rubber parts.
- Apply a thin layer of oil on the rammer shoe to prevent corrosion.
- Clean the air filter before storage.
- Carefully pull the starter rope handle until there is a small resistance.
- Put a protective cover on the product.
- Keep the product in a dry and frost free area.
- Keep the product in a locked area to prevent access for children or persons that are not approved.

Disposal

- Obey the local recycling requirements and applicable regulations.
- Discard all chemicals, such as engine oil or fuel, at a service center or at an applicable disposal location.
- When the product is no longer in use, send it to a Husqvarna dealer or discard it at a recycling location.

Technical data

| | Rammer shoe width 280 mm/11 in. | Rammer shoe width 330 mm/13 in. |
|--|-----------------------------------|-----------------------------------|
| Weight (uncrated, incl. oil, empty tanks) kg/lb | 96/212 | 97/214 |
| Operation weight (EN500, incl. oil, ½ fuel), kg/lb | 98/216 | 99/218 |
| Engine brand / Type | Hatz / 1B20R | Hatz / 1B20R |
| Engine power, kW/hp @rpm ¹ | 3/4 @2900 | 3/4 @2900 |
| Vibration frequency, Hz/rpm | 11.5/690 | 11.5/690 |
| Amplitude, mm/in. | 79.3/3.12 | 79.3/3.12 |
| Operation speed, m/min / ft./min | 11.5/37.7 | 11.5/37.7 |
| Fuel tank capacity, l/qts | 3.0/3.2 | 3.0/3.2 |
| Engine oil capacity *, l/qts | 0.9/0.95 | 0.9/0.95 |
| Fuel consumption, l/h / qts/h | 0.7/0.74 | 0.7/0.74 |
| Rammer leg oil capacity, l/qts | 0.9/0.95 | 0.9/0.95 |
| Fuel * | Ultra-low-sulfur diesel fuel only | Ultra-low-sulfur diesel fuel only |

¹ As specified by the engine manufacturer. The power rating of the engine indicated is the average net output (at specified rpm) of a typical production engine for the engine model measured to SAE standard J1349/ISO1585. Mass production engines may differ from this value. Actual power output for the engine installed on the final product will depend on the operating speed, environmental conditions and other values.

| | Rammer shoe width 280 mm/11 in. | Rammer shoe width 330 mm/13 in. |
|----------------|--|--|
| Engine oil * | Shell Rimula R4 L 15W-40 or SAE 10W-30, API Class SJ | Shell Rimula R4 L 15W-40 or SAE 10W-30, API Class SJ |
| Rammer leg oil | Shell Rimula R4 L 15W-40 or similar | Shell Rimula R4 L 15W-40 or similar |

* = For further information and questions about this specific engine, refer to the engine manual or the web site of the engine manufacturer.

| Noise and vibration emissions | |
|---|------|
| Sound power level, measured dB (A) | 106 |
| Sound power level, guaranteed L_{WA} dB (A) ² | 107 |
| Sound pressure level at the operator's ear, L_P , dB (A) ³ | 95 |
| Vibration level, a_{hv} , m/s^2 ⁴ | 11.9 |

Noise and vibration declaration statement

These declared values were obtained by laboratory type testing in accordance with the stated directive or standards and are suitable for comparison with the declared values of other products tested in accordance with the same directive or standards. These declared values are not suitable for use in risk assessments and values measured in individual work places may be higher. The actual exposure values and risk of harm experienced by an individual user are unique and depend upon the way the user works, in what material the product is used, as well as upon the exposure time and the physical condition of the user, and the condition of the product.

² Noise emissions in the environment measured as sound power (L_{WA}) as per EN ISO 3744 in conformity with EC directive 2000/14/EC. The difference between guaranteed and measured sound power is that the guaranteed sound power also includes dispersion in the measurement result and the variations between different machines of the same model according to Directive 2000/14/EC.

³ Sound pressure level L_P according to EN ISO 11201, EN 500-4. Uncertainty K_{PA} 3.5 dB (A).

⁴ Vibration value according to EN 500-4. Reported data for vibration level has a typical statistical dispersion (standard deviation) of $1.5 m/s^2$.

Product dimensions

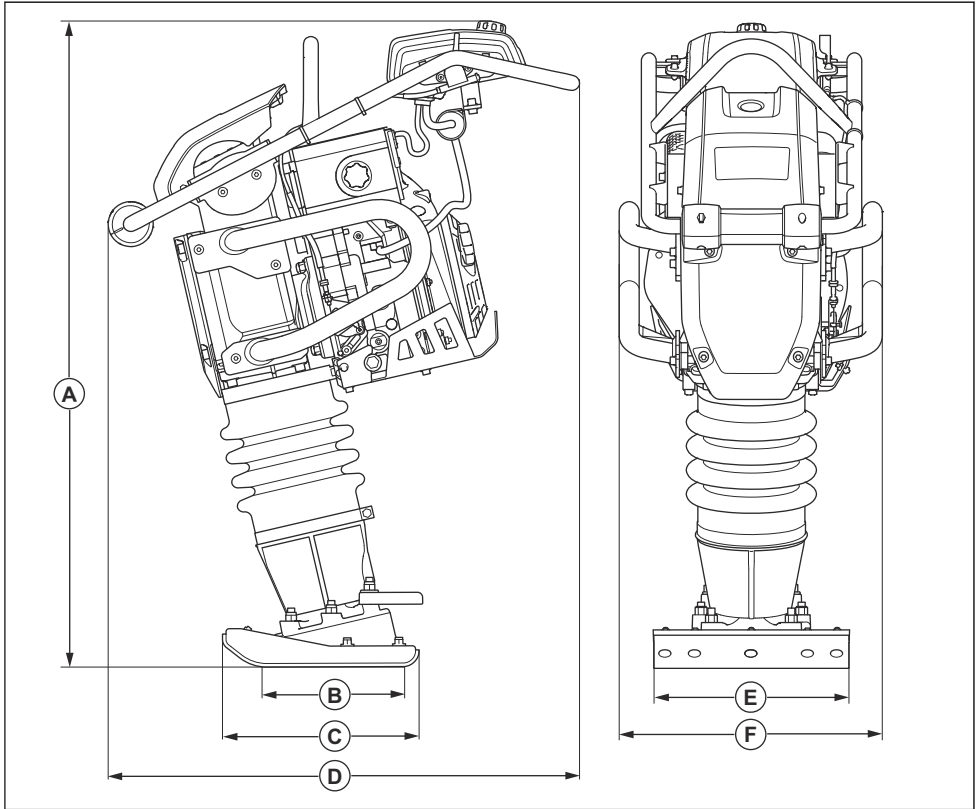

| | | | | | |
|----------|---|-------------------------|----------|---------------------------|-----------------|
| A | Height, mm/in. | 1088/42.8 | D | Length, mm/in. | 796/31.3 |
| B | Rammer shoe contact area, m ² /sq. ft. | 0.065/0.70 / 0.075/0.81 | E | Rammer shoe width, mm/in. | 280/11 / 330/13 |
| C | Rammer shoe length, mm/in. | 330/13 | F | Width, mm/in. | 444/17.5 |

EC Declaration of Conformity

EC Declaration of Conformity

We, **Husqvarna AB**, SE-561 82 Huskvarna, Sweden, tel: +46-36-146500, declare on our sole responsibility that the product:

| | |
|-----------------------|---|
| Description | Rammer Compaction Machine |
| Brand | Husqvarna |
| Type/Model | LT 8005 |
| Identification | Serial numbers dating from 2019 and onwards |

complies fully with the following EU directives and regulations:

| Directive/Regulation | Description |
|-----------------------------|-----------------------------|
| 2006/42/EC | "relating to machinery" |
| 2000/14/EC | "relating to outdoor noise" |

and that the following harmonized standards and/or technical specifications are applied;

EN 500-1+A1:2009

EN 500-4:2011

Notified body: 0038, Lloyd's Register Verification Limited, 71 Fenchurch Street, London, EC3M 4BS, UK, has certified conformity with the Council's Directive 2000/14/EC, Annex VIII, Full Quality Assurance.

For information relating to noise emissions, refer to the chapter *Technical data on page 13*.

Partille, 2019-05-08



Martin Huber
Global R&D Director
Concrete Surfaces & Floors
Husqvarna AB, Construction Division



www.husqvarnacp.com

Original instructions

1141124-26



2019-06-02