



# Husqvarna®



CRT 48-35L-PS  
CRT 48-37V-PS  
CRT 48-57K-PS

Husqvarna, 2019-12-01

## **Operator's manual, EN**

Dear customer,

Thank you for choosing a Husqvarna quality product. We hope that you will genuinely enjoy it.

Please note that the enclosed manual contains Wacker Neuson references.

The Husqvarna Group is vouching for the quality of this product.

If you have any questions, please do not hesitate to contact our local sales or service point, or visit [www.husqvarnacp.com](http://www.husqvarnacp.com).

Husqvarna AB

SE-561 82 Huskvarna, Sweden

# Operator's Manual

## Ride-On Trowel

# CRT48-35L-PS CRT48-37V-PS CRT48-57K-PS

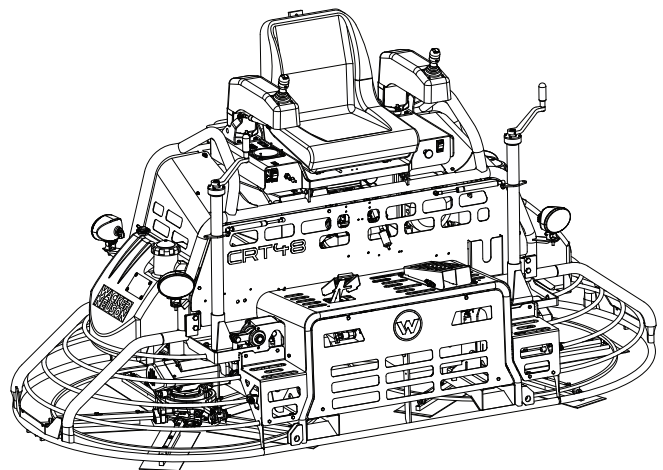

|          |   |
|----------|---|
| Type     | CRT48-35L-PS, CRT48-37V-PS,<br>CRT48-57K-PS |
| Document | 5000184417                                  |
| Date     | 0719  |
| Revision | 17  |
| Language | EN  |



## CALIFORNIA Proposition 65 Warning



### WARNING

The engine exhaust from this product contains chemicals known to the State of California to cause cancer, birth defects, or other reproductive harm.



### WARNING

Diesel engine exhaust and some of its constituents are known to the State of California to cause cancer, birth defects, and other reproductive harm.



### WARNING

Cancer and Reproductive Harm -  
[www.P65Warnings.ca.gov](http://www.P65Warnings.ca.gov).



### WARNING

Batteries, battery posts, terminals and related accessories contain lead and lead compounds, and other chemicals known to the State of California to cause cancer and birth defects or other reproductive harm. WASH HANDS AFTER HANDLING.

**NOTICE! CALIFORNIA AIR RESOURCES BOARD (CARB):** This machine is considered a preempt Off-Road Applicatoin as relating to CARB standards. The U.S. EPA has sole authority to establish emission standards for preempt construction equipment. For more information see [www.arb.ca.gov/msprog/offroad/preempt.htm](http://www.arb.ca.gov/msprog/offroad/preempt.htm)

# CALIFORNIA Proposition 65 Warning

Notes

**Foreword**

SAVE THESE INSTRUCTIONS—This manual contains important instructions for the machine models below. These instructions have been written expressly by Wacker Neuson Production Americas LLC and must be followed during installation, operation, and maintenance of the machines.

| Machine      | Item Number            |
|--------------|------------------------|
| CRT48-35L-PS | 5000620704, 5000620900 |
| CRT48-37V-PS | 5100024291             |
| CRT48-57K-PS | 5200018779, 5200018820 |

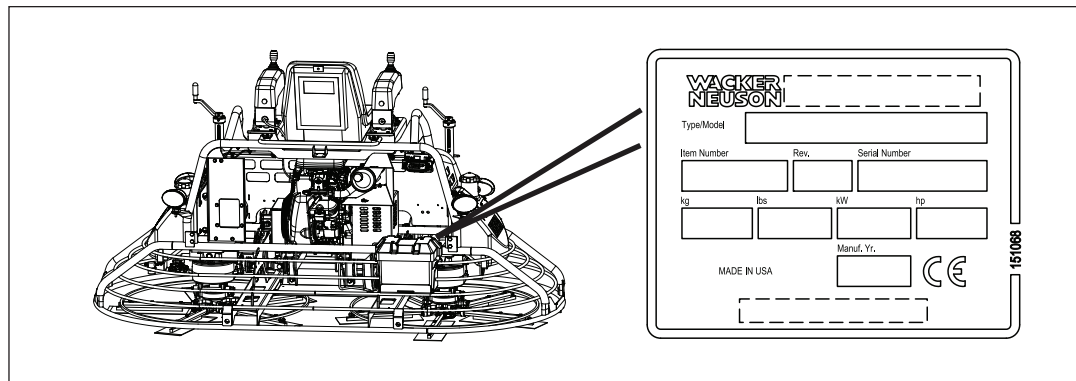

wc\_gr011846

**Machine identification**

A nameplate listing the model number, item number, revision number, and serial number is attached to this machine. The location of the nameplate is shown above.

**Serial number (S/N)**

For future reference, record the serial number in the space provided below. You will need the serial number when requesting parts or service for this machine.

Serial Number:

**Machine documentation**

- From this point forward in this documentation, Wacker Neuson Production Americas LLC will be referred to as Wacker Neuson.
- Keep a copy of the Operator’s Manual with the machine at all times.
- For spare parts information, please see your Wacker Neuson Dealer, or visit the Wacker Neuson website at <http://www.wackerneuson.com/>.
- When ordering parts or requesting service information, be prepared to provide the machine model number, item number, revision number, and serial number.

**Expectations for information in this manual**

- This manual provides information and procedures to safely operate and maintain the above Wacker Neuson model(s). For your own safety and to reduce the risk of injury, carefully read, understand, and observe all instructions described in this manual.
  - Wacker Neuson expressly reserves the right to make technical modifications, even without notice, which improve the performance or safety standards of its machines.
  - The information contained in this manual is based on machines manufactured up until the time of publication. Wacker Neuson reserves the right to change any portion of this information without notice.
  - The illustrations, parts, and procedures in this manual refer to Wacker Neuson factory-installed components. Your machine may vary depending on the requirements of your specific region.
- 

**CALIFORNIA Proposition 65 Warning**

Combustion exhaust, some of its constituents, and certain vehicle components contain or emit chemicals known to the State of California to cause cancer and birth defects or other reproductive harm.

---

**Laws pertaining to spark arresters**

**NOTICE:** State Health Safety Codes and Public Resources Codes specify that in certain locations spark arresters be used on internal combustion engines that use hydrocarbon fuels. A spark arrester is a device designed to prevent accidental discharge of sparks or flames from the engine exhaust. Spark arresters are qualified and rated by the United States Forest Service for this purpose. In order to comply with local laws regarding spark arresters, consult the engine distributor or the local Health and Safety Administrator.

---

**Manufacturer's approval**

This manual contains references to *approved* parts, attachments, and modifications. The following definitions apply:

- **Approved parts or attachments** are those either manufactured or provided by Wacker Neuson.
- **Approved modifications** are those performed by an authorized Wacker Neuson service center according to written instructions published by Wacker Neuson.
- **Unapproved parts, attachments, and modifications** are those that do not meet the approved criteria.

Unapproved parts, attachments, or modifications may have the following consequences:

- Serious injury hazards to the operator and persons in the work area
- Permanent damage to the machine which will not be covered under warranty

Contact your Wacker Neuson dealer immediately if you have questions about approved or unapproved parts, attachments, or modifications.



# EC Declaration of Conformity

We, **Husqvarna AB**, SE 561 82 Huskvarna, SWEDEN, Tel. +46 36 146500 declare on our sole responsibility that the product:

|                       |   |
|-----------------------|---|
| <b>Description</b>    | <b>Concrete Smoothing Machine, Trowel</b>   |
| <b>Brand</b>          | HUSQVARNA                                   |
| <b>Type / Model</b>   | CRT 48-57K-PS                               |
| <b>Identification</b> | Serial numbers dating from 2019 and onwards |

complies fully with the following EU directives and regulations:

| <b>Directive/Regulation</b> | <b>Description</b>                          |
|-----------------------------|---|
| 2006/42/EC                  | "relating to machinery"                     |
| 2014/30/EU                  | "relating to electromagnetic compatibility" |

and that the following standards and/or technical specifications are applied;

**EN 12649:2008+A1:2011**

Partille, 2019-12-01



Martin Huber

R&D Director, Concrete Surfaces & Floors  
Husqvarna AB, Construction Division

Responsible for technical documentation





|   |           |
|---|-----------|
| <b>CALIFORNIA Proposition 65 Warning</b>  | <b>3</b>  |
| <b>Foreword</b>   | <b>5</b>  |
| <b>EC Declaration of Conformity</b>   | <b>7</b>  |
| <b>1 Safety Information</b>   | <b>13</b> |
| 1.1 Signal Words Used in this Manual .....                                      | 13        |
| 1.2 Machine Description and Intended Use .....                                  | 14        |
| 1.3 Safety Guidelines for Operating the Machine .....                           | 15        |
| 1.4 Service Safety .....  | 17        |
| 1.5 Operator Safety while Using Internal Combustion Engines .....               | 19        |
| 1.6 Safety Guidelines for Lifting the Machine .....                             | 20        |
| 1.7 Hydraulic Oil Safety .....  | 20        |
| <b>2 Labels</b>   | <b>22</b> |
| 2.1 Label Locations .....   | 22        |
| 2.2 Label Meanings .....  | 23        |
| <b>3 Lifting and Transporting</b>   | <b>31</b> |
| 3.1 Lifting the Machine .....   | 31        |
| 3.2 Preparing the Machine for Transport on a Truck or Trailer .....             | 32        |
| <b>4 Operation</b>  | <b>35</b> |
| 4.1 Preparing the Machine for First Use .....                                   | 35        |
| 4.2 Position of the Operator .....  | 35        |
| 4.3 Machine Components .....  | 36        |
| 4.4 Machine Components Descriptions .....                                       | 37        |
| 4.5 Refueling the Machine .....   | 38        |
| 4.6 Break-In Period .....   | 39        |
| 4.7 Before Starting .....   | 39        |
| 4.8 Starting, Steering, Operating, and Stopping the Machine (Kohler) ....       | 40        |
| 4.9 Starting, Steering, Operating,<br>and Stopping the Machine (Vanguard) ..... | 43        |
| 4.10 Starting, Steering, Operating, and Stopping the Machine (Kubota) ...       | 46        |
| 4.11 Emergency Shutdown Procedure .....   | 48        |
| 4.12 Using the Steering Mode Switch .....                                       | 49        |

|           |   |           |
|-----------|---|-----------|
| 4.13      | Adjusting the Pitch .....                     | 50        |
| 4.14      | Steering Controller Fault Codes .....         | 51        |
| 4.15      | Using the Work Lights .....                   | 53        |
| 4.16      | Using the Retardant Spray System .....        | 54        |
| <b>5</b>  | <b>General Maintenance</b>                    | <b>55</b> |
| 5.1       | Maintaining the Emission Control System ..... | 55        |
| 5.2       | Periodic Maintenance Schedule .....           | 56        |
| 5.3       | Maintaining the Gearboxes .....               | 57        |
| 5.4       | Adjusting the Blade Arms .....                | 59        |
| 5.5       | Lubricate the Trowel Arms .....               | 61        |
| 5.6       | Mounting Float Pans .....                     | 62        |
| 5.7       | Replacing the Drive Belt .....                | 64        |
| 5.8       | Installing or Changing the Blades .....       | 66        |
| 5.9       | Cleaning the Machine .....                    | 68        |
| 5.10      | Storage .....                                 | 69        |
| 5.11      | Machine Disposal / Decommissioning .....      | 70        |
| <b>6</b>  | <b>Engine Maintenance: KOHLER</b>             | <b>71</b> |
| <b>7</b>  | <b>Engine Maintenance: Vanguard</b>           | <b>76</b> |
| <b>8</b>  | <b>Engine Maintenance: Kubota</b>             | <b>78</b> |
| <b>9</b>  | <b>Troubleshooting</b>                        | <b>83</b> |
| 9.1       | Setting Up the Diagnostic Tool .....          | 84        |
| <b>10</b> | <b>Technical Data</b>                         | <b>94</b> |
| 10.1      | Engine .....                                  | 94        |
| 10.2      | Trowel .....                                  | 95        |
| 10.3      | Sound Measurements .....                      | 96        |
| 10.4      | Vibration Measurements .....                  | 96        |
| 10.5      | Dimensions .....                              | 97        |

**11 Emission Control Systems Information and Warranty—Diesel 99**

11.1 Emission Control System Background Information ..... 99

11.2 Limited Defect Warranty for Wacker Neuson Emission Control Systems ..... 100

**12 Emission Control Systems Information and Warranty—Gasoline 105**

12.1 Emission Control System Background Information ..... 105

12.2 Limited Defect Warranty for Wacker Neuson Emission Control Systems ..... 106

**13 AEM Safety Manual 111**

**14 Schematics 129**

14.1 Electrical Schematic: CRT 48-35L-PS ..... 130

14.2 Electrical Schematic Components: CRT 48-35L-PS ..... 131

14.3 Electrical Schematic: CRT 48-37V-PS ..... 132

14.4 Electrical Schematic Components: CRT 48-37V-PS ..... 133

14.5 Fuse/Relay Box Layout ..... 133

14.6 Electrical Schematic: CRT 48-57K-PS ..... 134

14.7 Electrical Schematic Components: CRT 48-57K-PS ..... 135

14.8 Fuse/Relay Box Layout ..... 135

14.9 Electrical Schematic—Power Steer Circuit ..... 136

14.10 Electrical Schematic Components—Power Steer Circuit ..... 137

14.11 Hydraulic Schematic ..... 138

14.12 Hydraulic Schematic Components ..... 138



## 1 Safety Information

### 1.1 Signal Words Used in this Manual

This manual contains DANGER, WARNING, CAUTION, *NOTICE*, and NOTE signal words which must be followed to reduce the possibility of personal injury, damage to the equipment, or improper service.



This is the safety alert symbol. It is used to alert you to potential personal hazards.

- ▶ Obey all safety messages that follow this symbol.
- 



#### **DANGER**

DANGER indicates a hazardous situation which, if not avoided, will result in death or serious injury.

- ▶ To avoid death or serious injury from this type of hazard, obey all safety messages that follow this signal word.
- 



#### **WARNING**

WARNING indicates a hazardous situation which, if not avoided, could result in death or serious injury.

- ▶ To avoid possible death or serious injury from this type of hazard, obey all safety messages that follow this signal word.
- 



#### **CAUTION**

CAUTION indicates a hazardous situation which, if not avoided, could result in minor or moderate injury.

- ▶ To avoid possible minor or moderate injury from this type of hazard, obey all safety messages that follow this signal word.
- 

**NOTICE:** Used without the safety alert symbol, NOTICE indicates a situation which, if not avoided, could result in property damage.

**Note:** A Note contains additional information important to a procedure.

## 1.2 Machine Description and Intended Use

This machine is a ride-on concrete finishing trowel. The Wacker Neuson Ride-On Trowel consists of a frame onto which are mounted a gasoline or diesel engine, a fuel tank, a water tank, two gearboxes joined by a drive shaft, and an operator's platform with controls and a seat. A set of metal blades is connected to each gearbox. A ring guard surrounds the blades. The engine rotates the blades via the gearboxes and a clutch mechanism. The rotating blades ride on the surface of curing concrete, creating a smooth finish. The operator, who sits on the operator's platform, uses the controls and the throttle pedal to control speed and direction of the machine.

---

This machine is intended to be used for floating and burnishing curing concrete.

---

This machine has been designed and built strictly for the intended use described above. Using the machine for any other purpose could permanently damage the machine or seriously injure the operator or other persons in the area. Machine damage caused by misuse is not covered under warranty.

The following are some examples of misuse:

- Using the machine as a ladder, support, or work surface
  - Using the machine to carry or transport passengers or equipment
  - Using the machine to finish inappropriate materials such as slurries, sealers, or epoxy finishes
  - Operating the machine outside of factory specifications
  - Operating the machine in a manner inconsistent with all warnings found on the machine and in the Operator's Manual
- 

This machine has been designed and built in accordance with the latest global safety standards. It has been carefully engineered to eliminate hazards as far as practicable and to increase operator safety through protective guards and labeling. However, some risks may remain even after protective measures have been taken. They are called residual risks. On this machine, they may include exposure to:

- Heat, noise, exhaust, and carbon monoxide from the engine
- Chemical burns from the curing concrete
- Fire hazards from improper refueling techniques
- Fuel and its fumes, fuel spillage from improper lifting technique
- Personal injury from improper lifting techniques
- Cutting hazards from sharp or worn blades

To protect yourself and others, make sure you thoroughly read and understand the safety information presented in this manual before operating the machine.

### 1.3 Safety Guidelines for Operating the Machine

#### Operator training

Before operating the machine:

- Read and understand the operating instructions contained in all manuals delivered with the machine.
- Familiarize yourself with the location and proper use of all controls and safety devices.
- Contact Wacker Neuson for additional training if necessary.

When operating this machine:

- Do not allow improperly trained people to operate the machine. People operating the machine must be familiar with the potential risks and hazards associated with it.

#### Operator qualifications

Only trained personnel are permitted to start, operate, and shut down the machine. They also must meet the following qualifications:

- Have received instruction on how to properly use the machine
- Are familiar with required safety devices

The machine must not be accessed or operated by:

- Children
- People impaired by alcohol, drugs, or prescription drugs

#### Application area

Be aware of the application area.

- Keep unauthorized personnel, children, and pets away from the machine.
- Remain aware of changing positions and the movement of other equipment and personnel in the application area/job site.
- Identify whether special hazards exist in the application area, such as toxic gases or unstable ground conditions, and take appropriate action to eliminate the special hazards before using the machine.
- Do not operate the machine in areas that contain flammable objects, fuels, or products that produce flammable vapors.

#### Dust precaution

Dust created by construction activities may cause silicosis or respiratory harm. To reduce the risk of exposure:

- Work in a well ventilated area.
- Use a dust control system.
- Wear an approved dust/particle respirator.

#### Safety devices, controls, and attachments

Only operate the machine when:

- All safety devices and guards are in place and in working order.
- All controls operate correctly.
- The machine is set up correctly according to the instructions in the Operator's Manual.
- The machine is clean.
- The machine's labels are legible.

To ensure safe operation of the machine:

**Safe  
operating  
practices**

- Do not operate the machine if any safety devices or guards are missing or inoperative.
- Do not modify or defeat the safety devices.
- Only use accessories or attachments that are approved by Wacker Neuson.

When operating this machine:

- Remain aware of the machine's moving parts. Keep hands, feet, and loose clothing away from the machine's moving parts.
- Do not operate a machine in need of repair.
- Do not consume the operating fluids used in this machine. Depending on your machine model, these operating fluids may include water, wetting agents, fuel (gasoline, diesel, kerosene, propane, or natural gas), oil, coolant, hydraulic oil, heat transfer fluid (propylene glycol with additives), battery acid, or grease.

**Personal  
Protective  
Equipment  
(PPE)**

Wear the following personal protective equipment (PPE) while operating this machine:

- Close-fitting work clothes that do not hinder movement
- Safety glasses with side shields
- Hearing protection
- Safety-toed footwear

**After use**

- Stop the engine when the machine is not being operated.
- Close the fuel valve on engines equipped with one when the machine is not being operated.
- Ensure that the machine will not tip over, roll, slide, or fall when not being operated.
- Store the machine properly when it is not being used. The machine should be stored in a clean location out of the reach of children.





## 1.4 Service Safety

### Service training

Before servicing or maintaining the machine:

- Read and understand the instructions contained in all manuals delivered with the machine.
- Familiarize yourself with the location and proper use of all controls and protective devices.
- Only trained personnel shall troubleshoot or repair problems occurring with the machine.
- Contact Wacker Neuson for additional training if necessary.

When servicing or maintaining this machine:

- Do not allow untrained or improperly trained people to service or maintain the machine. Personnel servicing or maintaining the machine must be familiar with the associated potential risks and hazards.
- 

### Precautions

When servicing or maintaining the machine:

- Read and understand the service procedures before performing any service to the machine.
  - All adjustments and repairs must be completed before operating the machine. Do not operate the machine with a known problem or deficiency.
  - All repairs and adjustments shall be completed by a qualified technician.
  - Turn off the machine before performing maintenance or making repairs.
  - Remain aware of the machine's moving parts. Keep hands, feet, and loose clothing away from the machine's moving parts.
  - Reinstall the safety devices and guards after repair and maintenance procedures are complete.
- 

### Machine modifications

When servicing or maintaining the machine:

- Use only accessories/attachments that are approved by Wacker Neuson.
  - Do not defeat safety devices.
  - Do not modify the machine without the express written approval of Wacker Neuson.
- 

### Replacing parts and labels

- Replace worn or damaged components.
- Replace all missing and hard-to-read labels.
- When replacing electrical components, use components that are identical in rating and performance to the original components.
- When replacement parts are required for this machine, use only Wacker Neuson replacement parts or those parts equivalent to the original in all types of specifications, such as physical dimensions, type, strength, and material.

### Cleaning

When cleaning and servicing the machine:

- Keep machine clean and free of debris such as leaves, paper, cartons, etc.
- Keep labels legible.
- Clean with soapy water only.

When cleaning the machine:

- Do not clean the machine while it is running.

- Never use gasoline or other types of fuels or flammable solvents to clean the machine. Fumes from fuels and solvents can become explosive.
- 

### Personal protective equipment (PPE)

Wear the following Personal Protective Equipment (PPE) while servicing or maintaining this machine:

- Close-fitting work clothes that do not hinder movement
- Safety glasses with side shields
- Hearing protection
- Safety-toed footwear

In addition, before servicing or maintaining the machine:

- Tie back long hair.
- Remove all jewelry (including rings).

## 1.5 Operator Safety while Using Internal Combustion Engines



### WARNING

Internal combustion engines present special hazards during operation and fueling. Failure to follow the warnings and safety standards could result in severe injury or death.

- ▶ Read and follow the warning instructions in the engine owner's manual and the safety guidelines below.



### DANGER

Exhaust gas from the engine contains carbon monoxide, a deadly poison. Exposure to carbon monoxide can kill you in minutes.

- ▶ NEVER operate the machine inside an enclosed area, such as a tunnel, unless adequate ventilation is provided through such items as exhaust fans or hoses.

### Operating safety

When running the engine:

- Keep the area around the exhaust pipe free of flammable materials.
- Check the fuel lines and the fuel tank for leaks and cracks before starting the engine. Do not run the machine if fuel leaks are present or the fuel lines are loose.
- Do not smoke while operating the machine.
- Do not run the engine near sparks or open flames.
- Do not touch the engine or muffler while the engine is running or immediately after it has been turned off.
- Do not operate a machine when its fuel cap is loose or missing.
- Do not start the engine if fuel has spilled or a fuel odor is present. Move the machine away from the spill and wipe the machine dry before starting.

### Refueling safety

When refueling the engine:

- Clean up any spilled fuel immediately.
- Refill the fuel tank in a well-ventilated area.
- Reinstall the fuel tank cap after refueling.
- Do not smoke.
- Do not refuel a hot or running engine.
- Do not refuel the engine near sparks or open flames.
- Use suitable tools for refueling (for example, a fuel hose or a funnel).
- Do not refuel if the machine is positioned in a truck fitted with a plastic bed liner. Static electricity can ignite the fuel or fuel vapors.

## 1.6 Safety Guidelines for Lifting the Machine

When lifting the machine:

- Make sure slings, chains, hooks, ramps, jacks, forklifts, cranes, hoists, and any other type of lifting device used is attached securely and has enough weight-bearing capacity to lift or hold the machine safely. See the *Technical Data* chapter for machine weight.
- Remain aware of the location of other people when lifting the machine.
- Only use the lifting points and tie-downs described in the Operator's Manual.
- Make sure the transporting vehicle has sufficient load capacity and platform size to safely transport the machine.

To reduce the possibility of injury:

- Do not stand under the machine while it is being lifted or moved.
- Do not get onto the machine while it is being lifted or moved.

## 1.7 Hydraulic Oil Safety



### WARNING

Possibility of severe injury. Hydraulic oil is under high pressure and becomes very hot during operation.

- ▶ To avoid injury, obey the safety instructions listed below.

### Safety instructions

- Inspect the hydraulic system thoroughly before operating the machine.
- Do not touch hydraulic oil or hydraulic components while the machine is operating. Wait until the machine is cool.
- Before disconnecting hydraulic fittings or hoses, ensure that all pressure has been bled from the circuit. Set all controls in neutral, turn the engine off, and allow the fluids to cool before loosening hydraulic fittings or attaching test gauges.
- Hydraulic oil escaping under high pressure may penetrate the skin, causing burns, blindness, or other serious injuries or infections. Contact a physician immediately for treatment if your skin has been penetrated by hydraulic oil, even if the wound seems minor.
- Fluid leaks from small holes are often practically invisible. Do not use your bare hands to check for leaks. Check for leaks using a piece of cardboard or wood.
- Hydraulic oil is extremely flammable. Stop the engine immediately if a hydraulic leak is detected.
- After servicing the hydraulics, make sure all components are reconnected to the proper fittings. Failure to do so may result in damage to the machine and/or injury to a person on or near the machine.

Notes



2 Labels



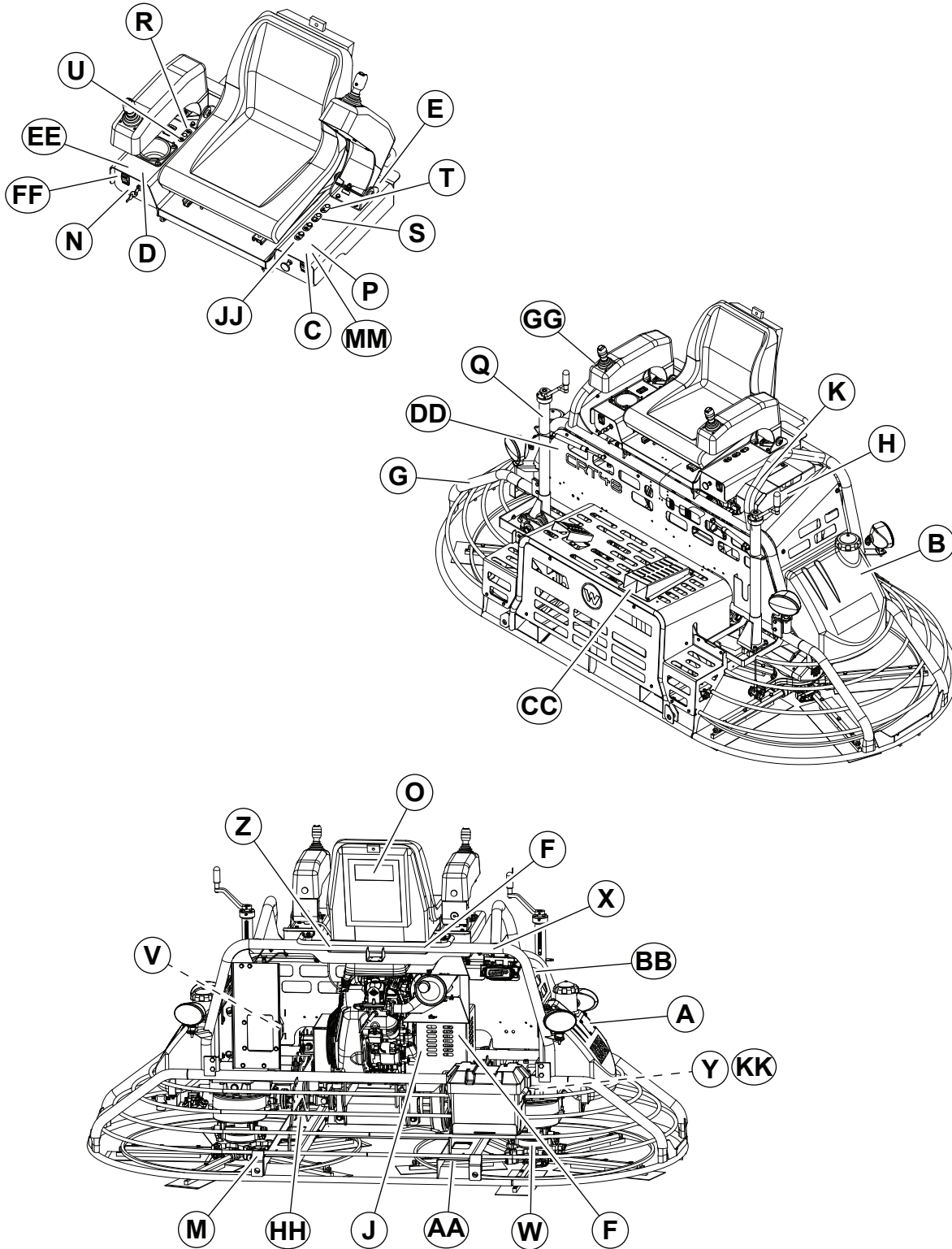



2.1 Label Locations





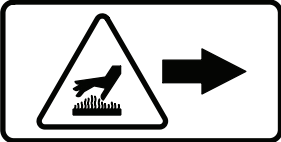

wc\_gr011891

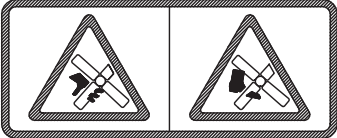

2.2 Label Meanings



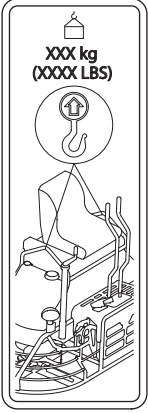
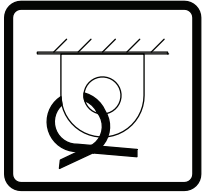
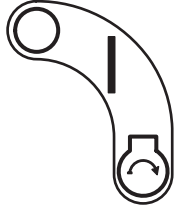

|          |  |   |
|----------|--|---|
| <p>A</p> |  | <p><b>DANGER</b><br/>Asphyxiation hazard</p> <ul style="list-style-type: none"> <li>Engines emit carbon monoxide.</li> <li>Do not run the machine indoors or in an enclosed area unless adequate ventilation, through such items as exhaust fans or hoses, is provided.</li> <li>Read the Operator's Manual.</li> <li>No sparks, flames, or burning objects near the machine.</li> <li>Stop the engine before refueling.</li> </ul> |
| <p>B</p> |  | <p>Water tank fill. Use only clean water or water-based retardants.</p>   |
| <p>C</p> |  | <p><b>WARNING</b><br/>Always wear hearing and eye protection when operating this machine.</p>   |
| <p>D</p> |  | <p>Steering control. See <i>Steering</i>.</p>   |

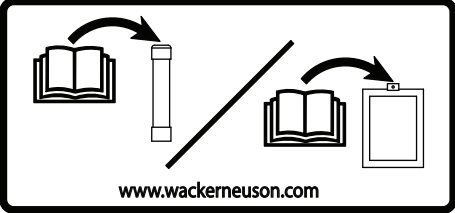
|          |  |   |
|----------|--|---|
| <p>E</p> |  <p>150349</p>  <p>178714</p>  | <p>Read and understand the supplied Operator's Manual before operating this machine. Failure to do so increases the risk of injury to yourself or others.</p> |
| <p>F</p> |  <p>117039</p>  <p>178713</p>  <p>117037</p>  <p>178732</p> | <p><b>WARNING</b><br/>Hot surface</p>   |
| <p>G</p> |  <p>111453</p>  <p>178740</p>  | <p><b>WARNING</b><br/>Cutting hazard. Keep hands and feet away from blades. Always replace blade guard.</p>   |

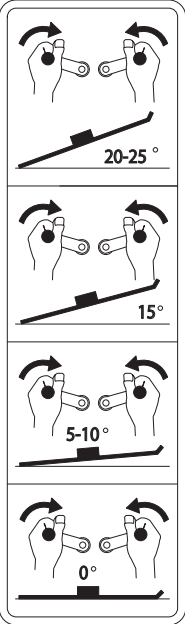
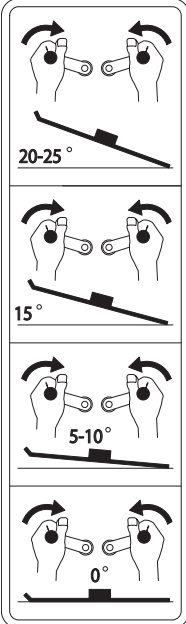

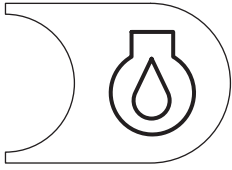
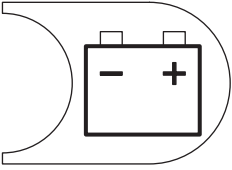
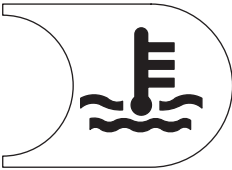

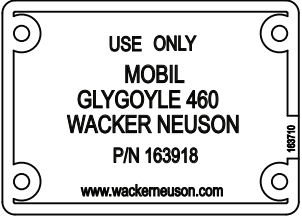

|          |   |  |
|----------|---|--|
| <p>H</p> |  <p>110164</p>  <p>178711</p> | <p>WARNING<br/>Pressurized contents. Do not open when hot!</p>                         |
| <p>J</p> |  <p>110033</p>  <p>178712</p> | <p>WARNING<br/>Hand injury if caught in moving belt.<br/>Always replace beltguard.</p> |
| <p>K</p> |  <p>5200014673</p>  | <p>NOTICE<br/>Lifting point</p>  |
| <p>M</p> |  <p>113726</p>   | <p>Tie-down point</p>  |
| <p>N</p> |  <p>118084</p>   | <p>Key switch, engine start:<br/>Off<br/>On<br/>Start</p>                              |

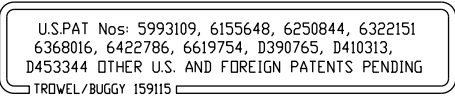
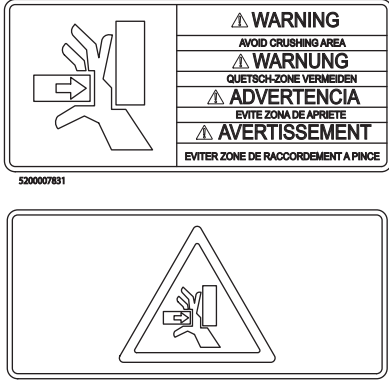
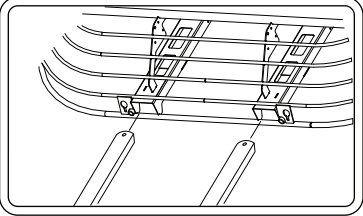
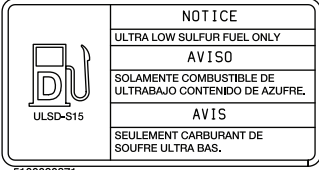
|          |   |  |
|----------|---|--|
| <p>O</p> | <div style="border: 1px solid black; padding: 5px;"> <p>OPERATOR'S MANUAL MUST BE STORED ON MACHINE. REPLACEMENT OPERATOR'S MANUAL CAN BE ORDERED THROUGH YOUR LOCAL WACKER DISTRIBUTOR.</p> <p>EL MANUAL DE OPERACION DEBE SER RETENIDO EN LA MAQUINA. CONTACTE A SU DISTRIBUIDOR WACKER MAS CERCANO PARA PEDIR UN EJEMPLAR ADICIONAL.</p> <p>LA NOTICE D'EMPLOI DOIT ETRE MUNIE SUR LA MACHINE. CONTACTER LE DISTRIBUTEUR WACKER LE PLUS PROCHE POUR COMMANDER UN EXEMPLAIRE SUPPLEMENTAIRE.</p> </div> <p>150350</p> <div style="border: 1px solid black; padding: 5px; text-align: center;">  <p>www.wackerneuson.com</p> </div> <p>180562</p> | <p>Operator's Manual must be stored on machine. Replacement Operator's Manual can be ordered through your local Wacker Neuson distributor.</p> |
| <p>P</p> | <div style="border: 1px solid black; padding: 5px;">  <p>5200007832</p> <div style="border: 1px solid black; padding: 5px; text-align: center;">  </div> <p>5200007834</p> </div>   | <p><b>WARNING</b><br/>Hot surface</p>  |
| <p>Q</p> | <div style="display: flex; justify-content: space-around;"> <div style="border: 1px solid black; padding: 5px; text-align: center;">  <p>118083 LEFT</p> </div> <div style="border: 1px solid black; padding: 5px; text-align: center;">  <p>118083 RIGHT</p> </div> </div>   | <p>Blade pitch control. Turn both controls inward to increase blade pitch. Refer to topic <i>Pitch Adjustment</i>.</p>                         |

|          |   |  |
|----------|---|--|
| <p>R</p> |  <p>164910</p>   | <p>CAUTION<br/>Engine oil pressure is low! Stop the engine and check the oil level.</p>          |
| <p>S</p> |  <p>164471</p>   | <p>CAUTION<br/>Low voltage! Stop the engine and check the charging system.</p>                   |
| <p>T</p> |  <p>164909</p>   | <p>CAUTION<br/>Coolant temperature is too high. Stop the engine and check the coolant level.</p> |
| <p>U</p> |  <p>165016</p>  | <p>CAUTION<br/>Glow plugs activated. Do not start engine until light turns off.</p>              |
| <p>V</p> |  <p>154857</p>  <p>178717</p> | <p>WARNING<br/>Entanglement hazard. Rotating machinery.</p>                                      |
| <p>W</p> |    | <p>Use <b>only</b> Glygoyle 460 gear oil in gearbox.</p>   |

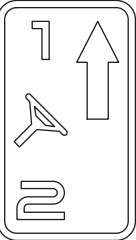
|           |   |   |
|-----------|---|---|
| <p>X</p>  |                  | <p><b>WARNING</b><br/>Explosion hazard.</p> <ul style="list-style-type: none"> <li>Do not use evaporative starting fluids such as ether on this engine.</li> <li>The engine is equipped with a cold starting aid. Using evaporative starting fluids can cause an explosion which can cause engine damage, personal injury, or death.</li> <li>Read and follow the engine starting instructions in this Operator's Manual.</li> </ul> <p>(if equipped)</p> |
| <p>Y</p>  |                  | <p>This machine may be covered by one or more patents.</p>  |
| <p>Z</p>  |                 | <p><b>WARNING</b><br/>Avoid crushing area.</p>  |
| <p>AA</p> |  <p>151108</p> | <p>Fork pockets</p>   |
| <p>BB</p> |                | <p><b>DANGER</b></p> <p><b>NOTICE</b><br/>Ultra low sulfur fuel only</p> <p>(if equipped)</p>   |

|           |  |  |
|-----------|--|--|
| <p>CC</p> |  <p>111760</p>  | <p>Hydraulic oil reservoir fill</p>  |
| <p>DD</p> |                 | <p>Dynamic Steering Stabilization</p>  |
| <p>EE</p> |  <p>182270</p>  | <p>Location of steering mode switch</p>  |
| <p>FF</p> |  <p>181230</p> | <p>Steering mode switch position</p>   |
| <p>GG</p> |               | <p>Emission Control Information<br/>This equipment meets U.S. EPA EVAP standards.<br/><br/>(if equipped)</p> |

|           |   |   |
|-----------|---|---|
| <p>HH</p> |   | <p>Read Operator's Manual.<br/>Steering system components are under load.<br/>See topic <i>Steering</i> or a trained service technician for adjustments.</p>  |
| <p>JJ</p> |   | <p>Caution<br/>Check engine.<br/><br/>(if equipped)</p>   |
| <p>KK</p> |   | <p>Industry Canada ICES-002 Compliance Label:<br/>CAN ICES-2/NMB-2</p>  |
| <p>MM</p> |   | <p>California Proposition 65 Warning<br/>Cancer and Reproductive Harm -<br/><a href="http://www.P65Warnings.ca.gov">www.P65Warnings.ca.gov</a>.</p>   |
| <p>—</p>  |   | <p>WARNING<br/>Remove pan from trowel before lifting machine overhead. Pans can fall and cause death or serious injury if a person is hit. (Label is located on top side of float pan.)</p>   |
| <p>—</p>  | <p>This Engine Is Certified To EPA Standards Only But Is Saleable In California In This Wacker Neuson Equipment Under The Farm And Construction Pre-Emption. Please See <a href="http://www.arb.ca.gov/msprog/offroad/preempt.htm">www.arb.ca.gov/msprog/offroad/preempt.htm</a> For More Information.<br/>5100042641</p> | <p>This engine is certified to EPA standards only but is saleable in California in this Wacker Neuson equipment under the farm and construction preemption. Please see <a href="http://www.arb.ca.gov/msprog/offroad/preempt.htm">www.arb.ca.gov/msprog/offroad/preempt.htm</a> for more information. (Label is located on the engine.)</p> |

### 3 Lifting and Transporting

#### 3.1 Lifting the Machine

**Background** The machine is equipped with fork lift pockets (**a**) on the front and back, and two lifting tubes (**b**).

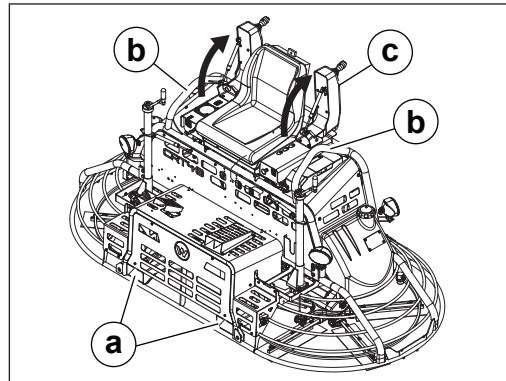

wc\_gr011877

- Requirements**
- Lifting equipment (crane, hoist, or fork truck) capable of supporting the machine's weight
  - Lifting devices (hooks, chains, and shackles) capable of supporting the machines' weight
  - Machine stopped
  - Armrests (**c**) in the transport position

#### Lifting the machine

Perform the procedure below to lift the machine.

1. Attach a sling or chain through the lifting tubes or use a fork lift. Do not attach lifting devices to any other part of the machine.
2. Lift the machine a small distance.



#### WARNING

Crushing hazard. An unstable machine may cause the lifting devices and equipment to fail. You may be crushed if the lifting devices and equipment fail.

- ▶ Check for stability before continuing.

3. Check for stability. If necessary, lower the machine, reposition the lifting devices, and lift the machine a small distance again.
4. Continue lifting the machine only when it is stable.

### 3.2 Preparing the Machine for Transport on a Truck or Trailer

- Requirements**
- Machine stopped
  - Flatbed truck or trailer capable of supporting the machine's weight
  - Chains, hooks, or straps capable of supporting the machine's weight



---

**WARNING**

Crushing hazard. Improperly securing the machine can lead to a crushing hazard.

- ▶ Use only the designated tie-down points to secure the machine to a truck or trailer.
- 

**Checklist**

Before transporting the machine, check the following items:

- Check that the transport vehicle or trailer can support the weight of the machine.
- Check that the transport vehicle or trailer is wide enough to support the machine.
- Check that the wheels of the transport vehicle or trailer are chocked during the loading process.
- Check that the transport vehicle or trailer is clean and free of grease, oil, ice, and other loose material.
- If the machine is mounted to a trailer, do not use the machine's trailer jack to support the trailer tongue during transporting.
- Check that any ramps used in the loading process:
  - Can support the weight of the machine.
  - Are clean and free of grease, oil, ice, and other loose material.
  - Are securely connected to the transport vehicle or trailer.
  - Are of sufficient length to keep the loading angle 15° or less.

**In addition:**

- Check that the loading area is flat and the ground is stable.
- Check the overall height of the machine once it is loaded on the truck or trailer.
- Plan your travel route so there will be adequate clearance for overpasses, road signs, buildings, etc.
- Check local regulations regarding transporting and obey these regulations.



**Note:** *Graphic is representative only. Your machine may vary.*

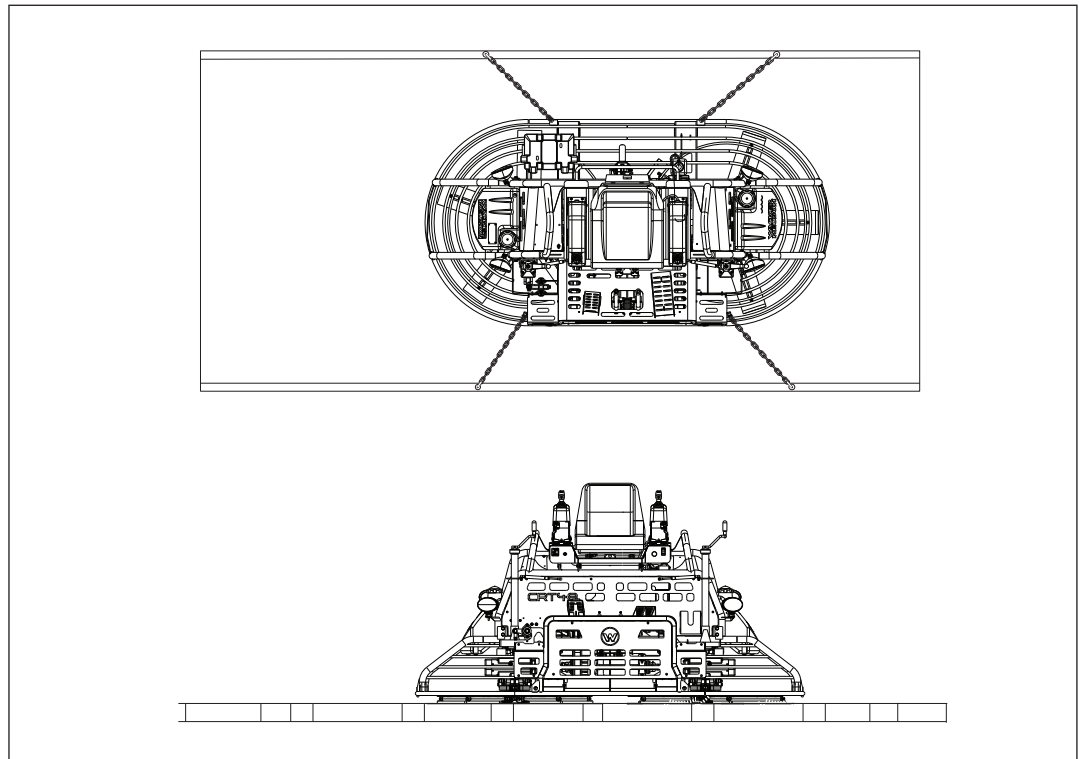

wc\_gr011880

Notes



## 4 Operation

### 4.1 Preparing the Machine for First Use

1. Make sure all loose packaging materials have been removed from the machine.
2. Check the machine and its components for damage. If there is visible damage, do not operate the machine. Contact your Wacker Neuson dealer immediately for assistance.
3. Take inventory of all items included with the machine and verify that all loose components and fasteners are accounted for.
4. Attach component parts not already attached.
5. Add fluids as needed and applicable, such as fuel and engine oil.
6. Move the machine to its operating location.

### 4.2 Position of the Operator

Safe and efficient use of this machine is the operator's responsibility. Full control of the machine is not possible unless the operator maintains the proper working position at all times.

While operating this machine the operator must:

- Be seated in the operator's seat facing forward
- Have both feet on the control deck
- Have both hands on the controls

4.3 Machine Components

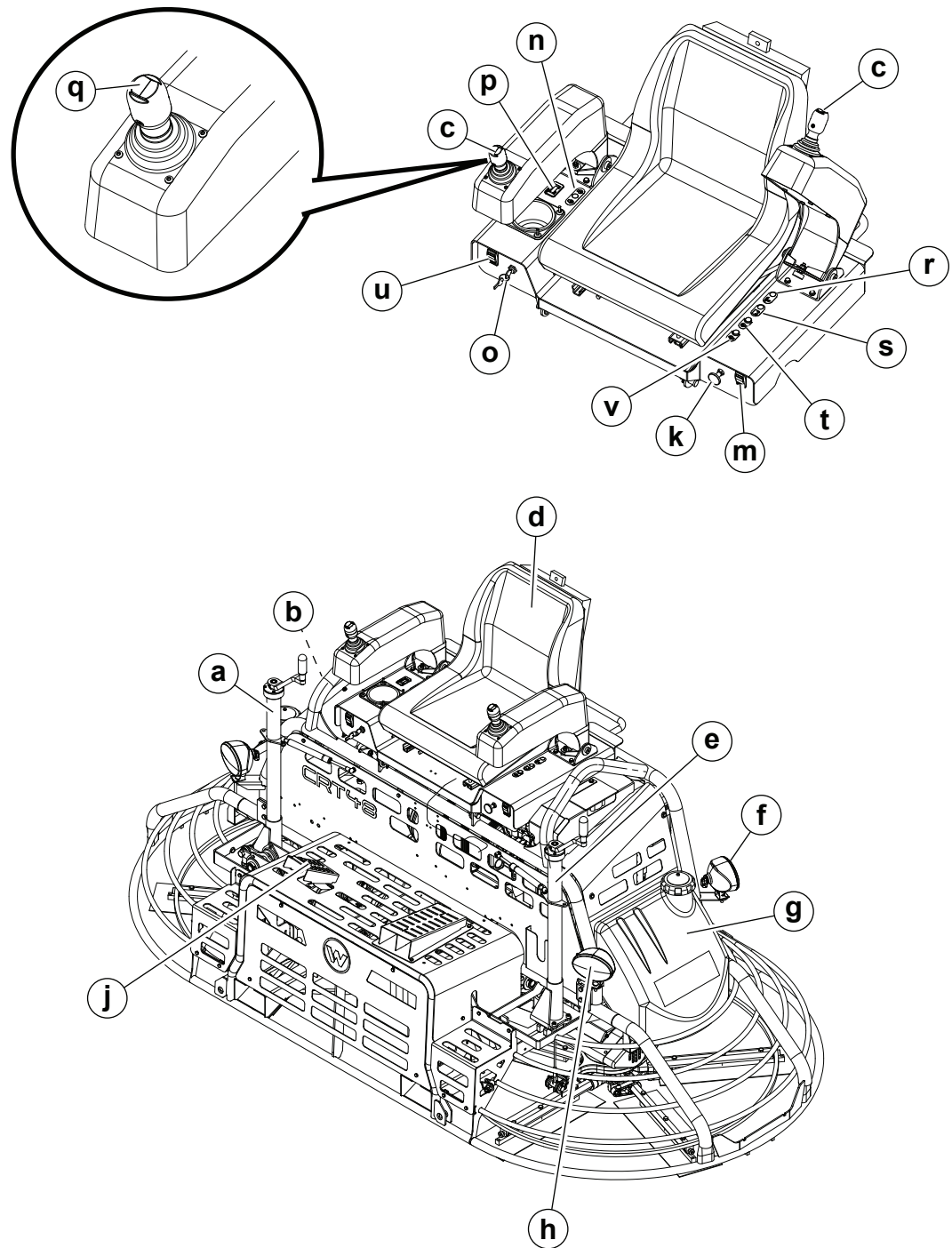

wc\_gr011905

### 4.4 Machine Components Descriptions

| Ref. | Description                                     | Ref. | Description                                |
|------|---|------|--|
| a    | Right pitch control                             | m    | Work light switch                          |
| b    | Fuel tank                                       | n    | Glow plug indicator light (if equipped)    |
| c    | Joysticks                                       | o    | Engine keyswitch                           |
| d    | Operator's seat with "operator presence" switch | p    | Hour meter                                 |
| e    | Left pitch control                              | q    | Water spray control                        |
| f    | Rear work light (one each side)                 | r    | Oil pressure indicator light               |
| g    | Water tank                                      | s    | Alternator charging indicator light        |
| h    | Front work light (one each side)                | t    | Coolant temperature indicator light        |
| j    | Foot pedal (throttle control)                   | u    | Steering mode switch                       |
| k    | Engine choke control (if equipped)              | v    | Check engine indicator light (if equipped) |

**Operator presence system**

The Ride-On Trowel features a seat with an integrated "operator presence" system which works in conjunction with a throttle-mounted switch. This system allows the engine to remain running (idling) with no operator seated in the seat, as long as the throttle is not depressed.

The purpose of the "operator presence" system is to reduce the throttle to idle if the operator leaves the seat. The "operator presence" system meets requirement published by organizations such as OSHA, ANSI, and ISO.

**Learning to operate the trowel**

To familiarize a new operator with the Ride-On Trowel, the following steps should be taken:

1. With the operator in the seat, show him or her the functions of the joysticks (c) and how to start the machine.
2. Have the operator practice steering the trowel. A hard concrete slab slightly wetted with water is an ideal surface on which to practice.
3. Pitch the blades up approximately 6.35 mm (1/4") on the leading edge. Start by making the machine hover in one spot, and then practice moving the machine in a straight line and making 180° turns. The best control is achieved at full rpm.



## 4.5 Refueling the Machine

- Requirements**
- Machine shut down
  - Engine cool
  - Machine/fuel tank level with the ground
  - Fresh, clean fuel supply

**Procedure** Perform the procedure below to refuel the machine.



### WARNING

Fire and burn hazard. Fuel and its vapors are extremely flammable.

- ▶ Keep all sources of ignition away from the machine while refueling.
- ▶ Refuel only when the machine is outdoors.
- ▶ Clean up spilled fuel immediately.

1. Remove the fuel cap (a).

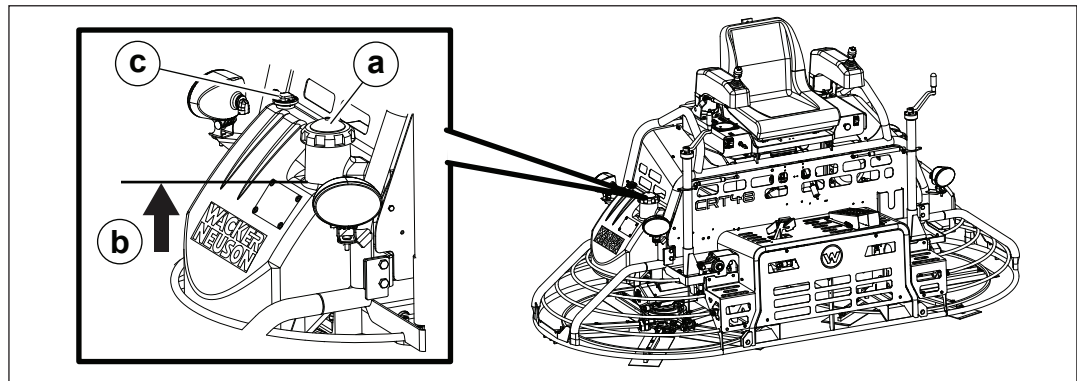

wc\_gr011849

2. Fill the fuel tank up to the base of the neck (b). The tank includes an expansion space for proper operation of the venting port (c).



### CAUTION

Fire and health hazard. Fuel expands when heated. Expanding fuel in an over-filled tank can lead to spills and leaks.

- ▶ Do not overfill the fuel tank.
- ▶ Do not modify, bypass, or remove the venting port.

3. Re-install the fuel cap.

**Result** The machine has now been refueled.

## 4.6 Break-In Period

|  |   |
|--|---|
| <b>Overview</b>                        | This machine requires a break-in period for the engine and the gearbox.   |
| <b>Gearbox break-in period</b>         | <p>To break in the gearboxes, run the engine at 50% of full throttle for the first 2–4 hours. This will prevent premature wear and extend gear life.</p> <p><b>NOTICE:</b> Running the engine at full throttle during the break-in period could result in premature gear failure.</p>   |
| <b>Kohler engine break-in period</b>   | <p>Follow the recommendations below while operating the machine during the break-in period.</p> <ul style="list-style-type: none"> <li>■ The Kohler engine has a 50-hour break-in period.</li> <li>■ During the first 50 hours, do not exceed 70% of maximum rated power.</li> <li>■ Change the engine oil and oil filter after the first 50 hours of operation.</li> <li>■ Allow the engine to warm up completely before operating the machine in cold weather.</li> </ul> |
| <b>Vanguard engine break-in period</b> | <p>Follow the recommendations below while operating the machine during the break-in period.</p> <ul style="list-style-type: none"> <li>■ Do not operate at full load during the first 5–10 hours of operation.</li> <li>■ Change the oil after the first 5–10 hours of operation.</li> <li>■ Allow the machine to warm up completely before operating the machine in cold weather.</li> </ul>   |
| <b>Kubota engine break-in period</b>   | <p>Follow the recommendations below while operating the machine during the break-in period.</p> <ul style="list-style-type: none"> <li>■ Change the oil and oil filter after the first 50 hours of operation.</li> <li>■ Allow the machine to warm up completely before operating the machine in cold weather.</li> </ul>   |

## 4.7 Before Starting

|                    |   |
|--------------------|---|
| <b>Requirement</b> | Operator must be familiar with the location and function of all controls.   |
| <b>Checklist</b>   | <p>Check the following items before starting the trowel:</p> <ul style="list-style-type: none"> <li><input type="checkbox"/> fuel level—add fuel as needed</li> <li><input type="checkbox"/> oil level in the engine—add oil as needed</li> <li><input type="checkbox"/> water level—add water as needed</li> <li><input type="checkbox"/> air filter—element is clean and undamaged</li> <li><input type="checkbox"/> trowel arms and blades—functional and undamaged</li> </ul> |

## 4.8 Starting, Steering, Operating, and Stopping the Machine (Kohler)

- Requirements**
- Machine is in serviceable condition and has been properly maintained
  - There is fuel in the tank



### CAUTION

Personal injury hazard. Operating the trowel with the armrests in the transport position can lead to personal injury.

- ▶ Do not operate the machine with the armrests in the transport position.

### Starting the machine

Perform the procedure below to start the machine.

1. Sit in the operator's seat.
2. Turn the starting key (a) clockwise to the ON position.

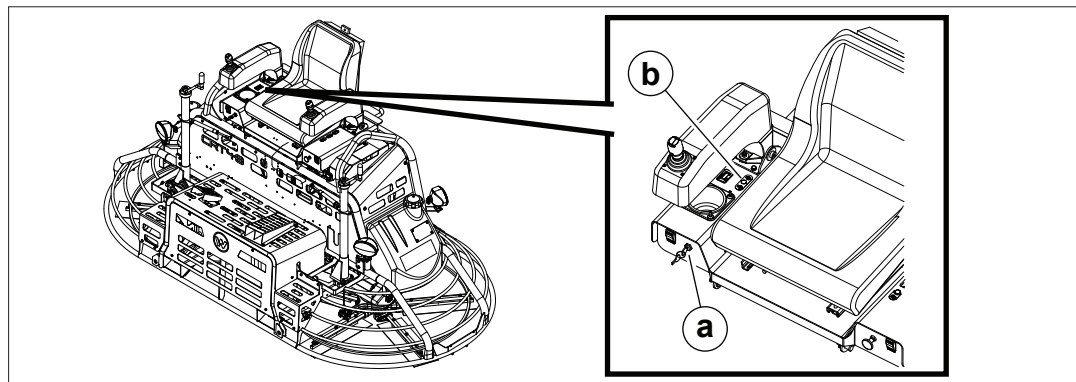

wc\_gr011856

3. When the glow plug indicator light (b) turns off, turn the key switch to the START position and hold until the engine starts.

**NOTICE:** Cranking the engine for more than five seconds can cause starter damage.

- If the engine fails to start, release the key switch and wait 10 seconds before operating the starter again.
- If the engine still will not start after multiple attempts, see chapter *Troubleshooting*.

4. Allow the engine to warm up before operating the machine.
5. Press the throttle pedal to engage the blades.



Steering

The joysticks (c) control the travel direction and rotation of the machine.

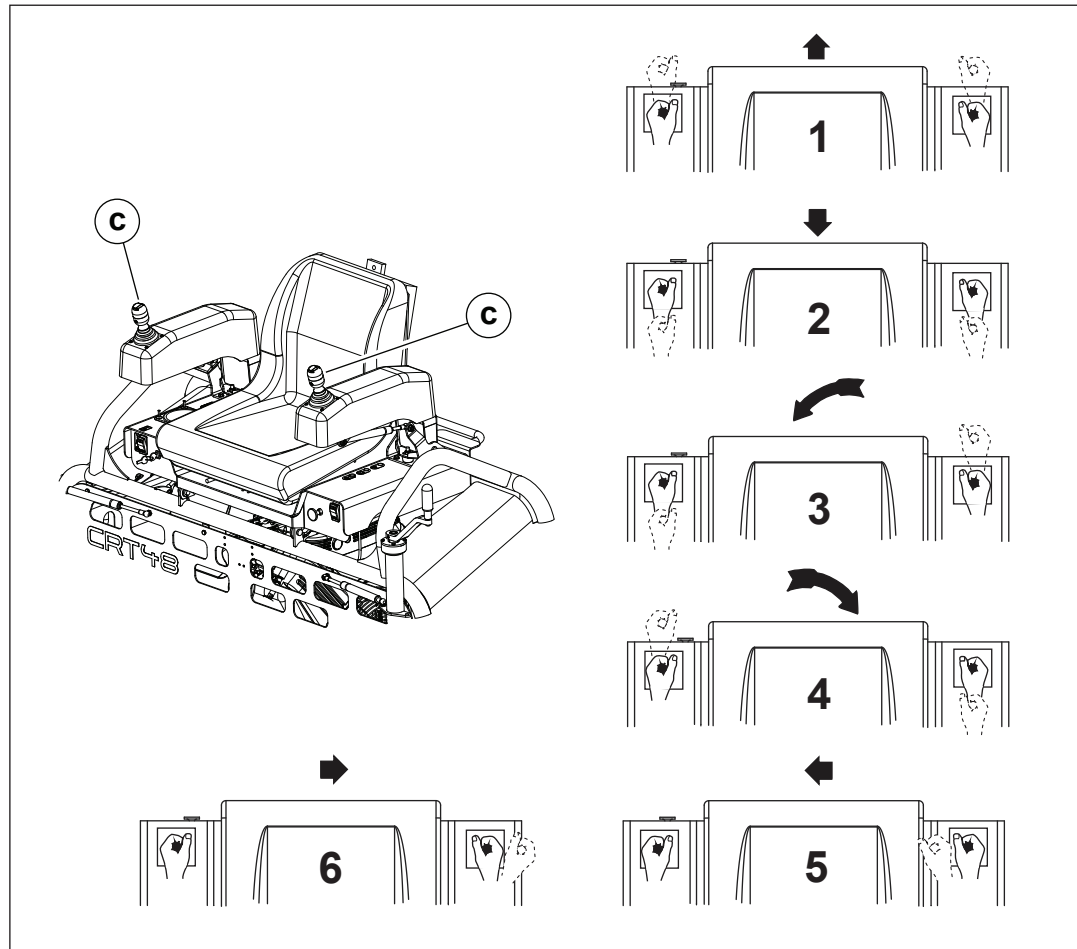

wc\_gr011857

Hand motions

Refer to the illustration for the necessary joystick motions to move the trowel in the desired direction.

- 1 — forward
- 2 — reverse
- 3 — rotate counter-clockwise
- 4 — rotate clockwise
- 5 — move left sideways
- 6 — move right sideways

**Note:** The left joystick moves in only two directions: forward and backward. When the trowel is operated sideways (5 and 6), the right joystick controls machine movement while the left joystick remains stationary.

## Operating the machine

Follow the guidelines below to use your Ride-On Trowel to its fullest capacity.

- Operate the machine in the direction that the operator is facing. This will finish the widest possible area, while giving the operator an excellent view of the slab surface to be troweled.
- When the machine reaches the end of the slab, make a 180° U-turn and repeat the straight line of direction to the other end of the slab.
  - Alternatively, move the machine laterally (sideways) and then travel backward to the other end of the slab.
- Remember that the best possible control is achieved at maximum engine speed.

**NOTICE:** Do not use excessive pressure on the joysticks. Excessive pressure does not increase the reaction time of the machine and can damage the steering controls.

---

## Stopping the machine

1. Stop trowel movement by returning the joysticks to their neutral positions and releasing pressure on the throttle foot pedal.
2. Shut off the engine by turning the key switch to "O" (OFF) position.

## 4.9 Starting, Steering, Operating, and Stopping the Machine (Vanguard)

- Requirements**
- Machine is in serviceable condition and has been properly maintained
  - There is fuel in the tank



### CAUTION

Personal injury hazard. Operating the trowel with the armrests in the transport position can lead to personal injury.

- ▶ Do not operate the machine with the armrests in the transport position.

### Starting the machine

Perform the procedure below to start the machine.

1. Sit in the operator's seat.
2. Turn the starting key (a) clockwise until the engine starts.

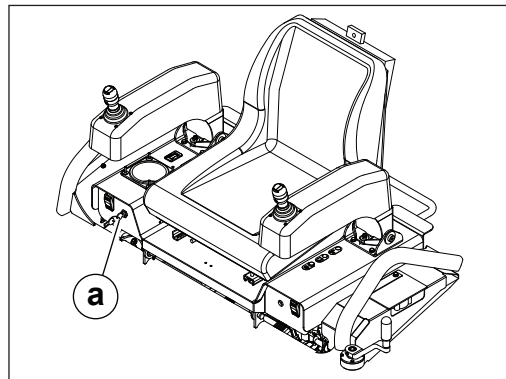

wc\_gr014073

**NOTICE:** Cranking the engine for more than five seconds can cause starter damage.

- If the engine fails to start, release the key switch and wait 10 seconds before operating the starter again.
- If the engine still will not start after multiple attempts, see chapter *Troubleshooting*.

3. Press the throttle pedal to engage the blades.

*This procedure continues on the next page.*

Continued from the previous page.

## Steering

The joysticks (**b**) control the travel direction and rotation of the machine.

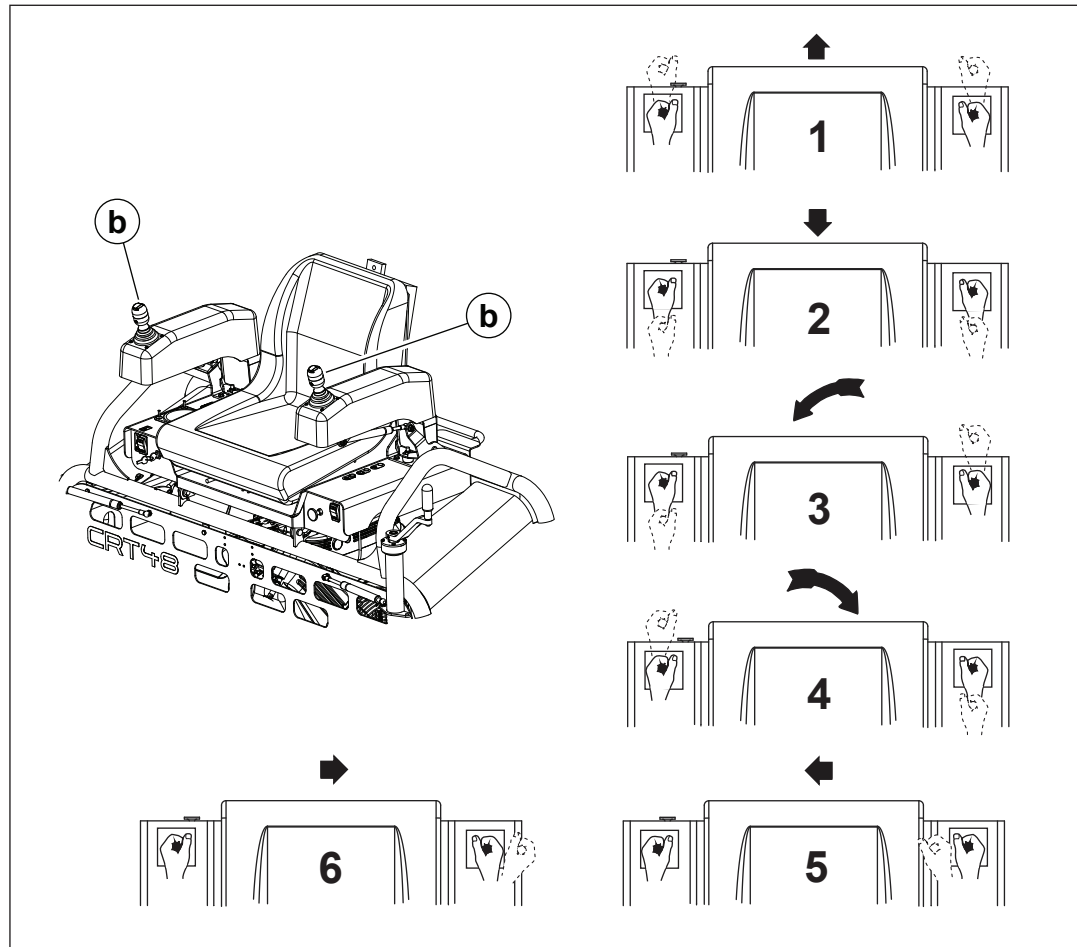

wc\_gr012802

**Hand motions** Refer to the illustration for the necessary joystick motions to move the trowel in the desired direction.

- 1 — forward
- 2 — reverse
- 3 — rotate counter-clockwise
- 4 — rotate clockwise
- 5 — move left sideways
- 6 — move right sideways

**Note:** The left joystick moves in only two directions: forward and backward. When the trowel is operated sideways (5 and 6), the right joystick controls machine movement while the left joystick remains stationary.

**Operating the machine**

Follow the guidelines below to use your Ride-On Trowel to its fullest capacity.

- Operate the machine in the direction that the operator is facing. This will finish the widest possible area, while giving the operator an excellent view of the slab surface to be troweled.
- When the machine reaches the end of the slab, make a 180° U-turn and repeat the straight line of direction to the other end of the slab.
  - Alternatively, move the machine laterally (sideways) and then travel backward to the other end of the slab.
- Remember that the best possible control is achieved at maximum engine speed.

**NOTICE:** Do not use excessive pressure on the joysticks. Excessive pressure does not increase the reaction time of the machine and can damage the steering controls.

---

**Stopping the machine**

1. Stop trowel movement by returning the joysticks to their neutral positions and releasing pressure on the throttle foot pedal.
2. Shut off the engine by turning the key switch to "O" (OFF) position.

### 4.10 Starting, Steering, Operating, and Stopping the Machine (Kubota)

- Requirements**
- Machine is in serviceable condition and has been properly maintained
  - There is fuel in the tank



**CAUTION**

Personal injury hazard. Operating the trowel with the armrests in the transport position can lead to personal injury.

- ▶ Do not operate the machine with the armrests in the transport position.

**Starting the machine**

Perform the procedure below to start the machine.

1. Sit in the operator's seat.
2. Turn the starting key (a) clockwise to the crank position until the engine starts.

**NOTICE:** Cranking the engine for more than five seconds can cause starter damage.

- If the engine fails to start, release the key switch and wait 10 seconds before operating the starter again.
- If the engine still will not start after multiple attempts, see chapter *Troubleshooting*.

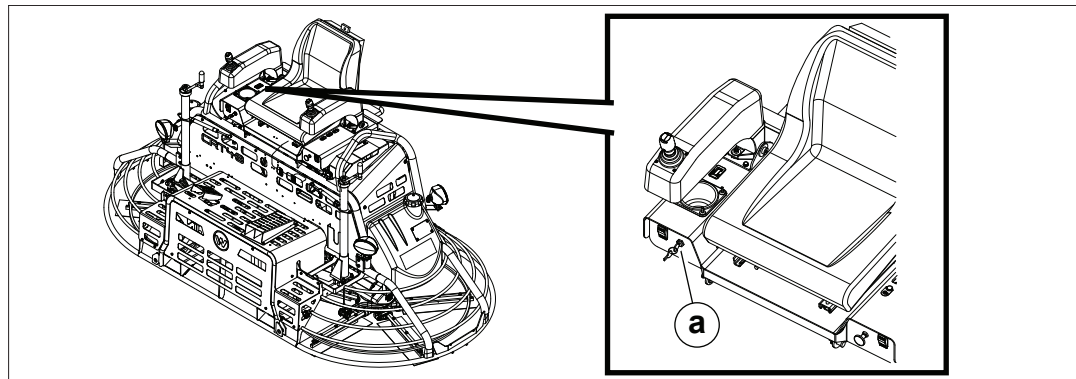

wc\_gr012801

3. Allow the engine to warm up before operating the machine.
4. Press the throttle pedal to engage the blades.

Steering

The joysticks (b) control the travel direction and rotation of the machine.

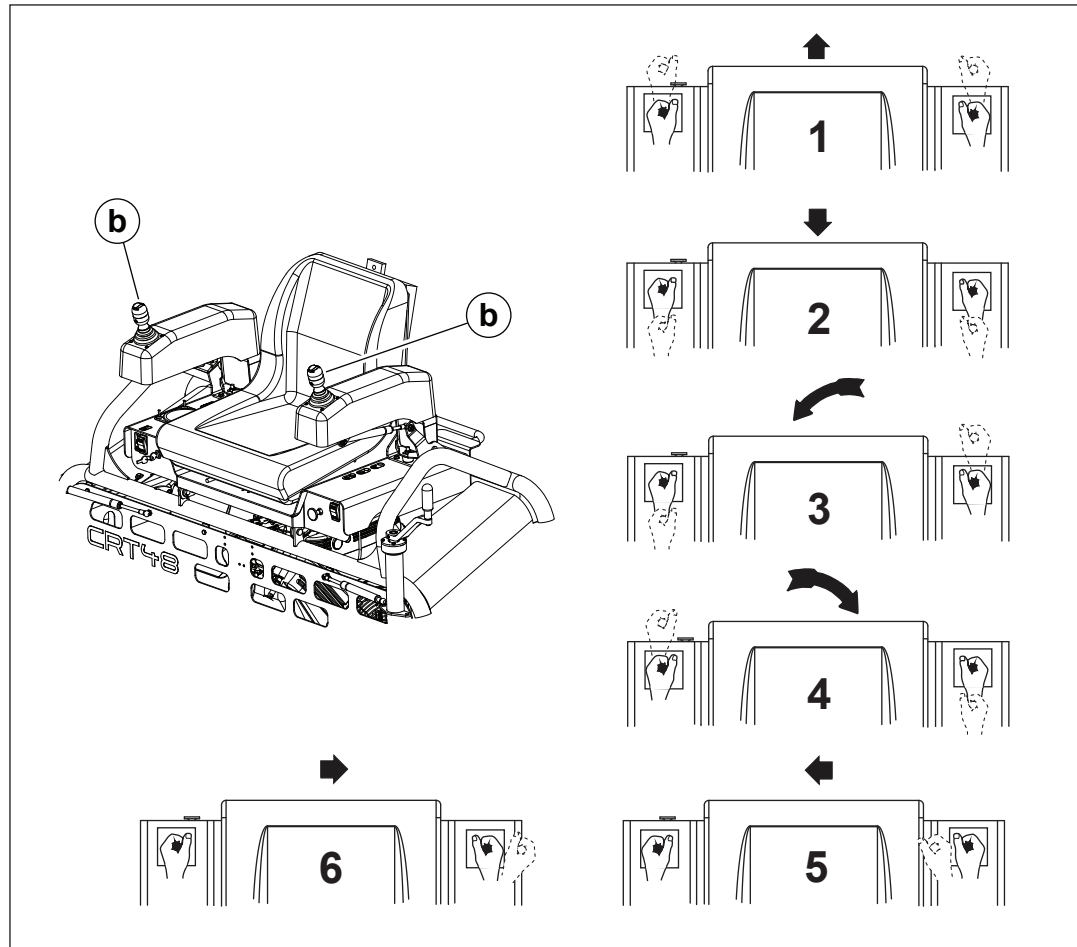

wc\_gr012802

**Hand motions** Refer to the illustration for the necessary joystick motions to move the trowel in the desired direction.

- 1 — forward
- 2 — reverse
- 3 — rotate counter-clockwise
- 4 — rotate clockwise
- 5 — move left sideways
- 6 — move right sideways

**Note:** *The left joystick moves in only two directions: forward and backward. When the trowel is operated sideways (5 and 6), the right joystick controls machine movement while the left joystick remains stationary.*

**Operating the machine**

Follow the guidelines below to use your Ride-On Trowel to its fullest capacity.

- Operate the machine in the direction that the operator is facing. This will finish the widest possible area, while giving the operator an excellent view of the slab surface to be troweled.
- When the machine reaches the end of the slab, make a 180° U-turn and repeat the straight line of direction to the other end of the slab.
  - Alternatively, move the machine laterally (sideways) and then travel backward to the other end of the slab.
- Remember that the best possible control is achieved at maximum engine speed.

**NOTICE:** Do not use excessive pressure on the joysticks. Excessive pressure does not increase the reaction time of the machine and can damage the steering controls.

---

**Stopping the machine**

1. Stop trowel movement by returning the joysticks to their neutral positions and releasing pressure on the throttle foot pedal.
2. Shut off the engine by turning the key switch to "O" (OFF) position.

## 4.11 Emergency Shutdown Procedure

**Procedure**

If a breakdown or accident occurs while the machine is operating, follow the procedure below:

1. Stop the engine.
2. Close the fuel valve.
3. Remove the machine from the job site.
4. Clean concrete from the blades and the machine.
5. Contact the rental yard or machine owner for further instructions.



### 4.12 Using the Steering Mode Switch

**Overview**

The steering mode switch (a) allows the operator to adjust the response of the joysticks depending upon the intended machine movement or concrete surface condition.

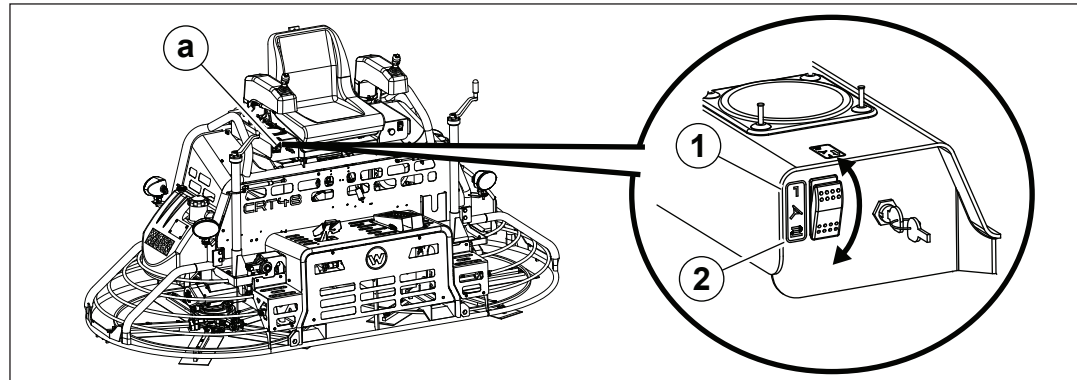

wc\_gr011858

**Switch positions**

| Position | Meaning         | Machine response  | Recommended use  |
|----------|-----------------|---|--|
| 1        | High resolution | Joysticks display standard response to operator's hand movements. Larger hand movements are required to control machine motion. | Intended for use when edging, finishing around poles, or operating on extremely sticky surfaces.                                 |
| 2        | High rate       | Joysticks display increased response to operator's hand movements. Smaller adjustments are required to control machine motion.  | Best for use when panning, traveling at high speeds, or when minimum directional control is required while covering large areas. |

### 4.13 Adjusting the Pitch

**Background** Changing the pitch (angle) of the trowel blades enables the operator to finish concrete from the wet surface stage through the hard finishing stage (burnishing).

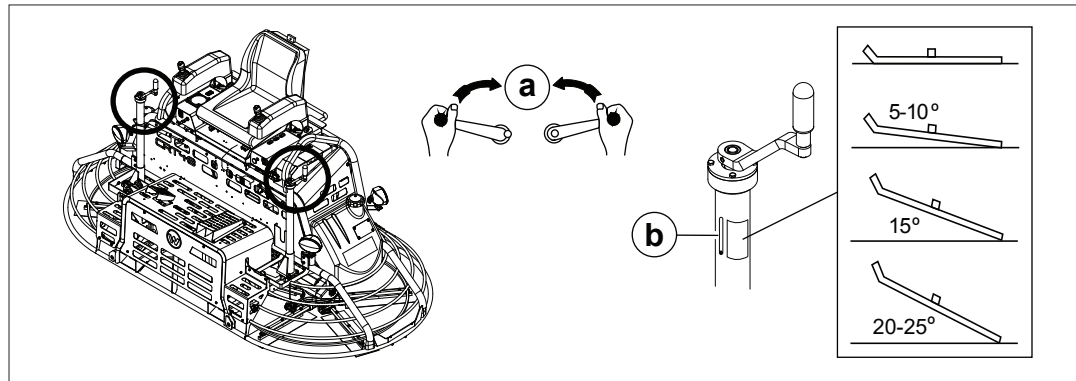

wc\_gr011860

**Changing pitch angle**

Perform the procedure below to change or set the pitch angle of the trowel blades.

1. Slow the machine.
2. Set the desired pitch on the left side of the machine. To increase the pitch, turn the pitch control inward **(a)**.
3. Adjust the right side to match.
4. Use the pitch indicator **(b)** to adjust pitch equally on both right and left trowel blades.

**Suggested working pitch**

| Working conditions of concrete       | Suggested working pitch |
|--------------------------------------|-------------------------|
| 1. Wet surface working stage         | Flat (no pitch)         |
| 2. Wet to plastic working stage      | Slight pitch (5–10°)    |
| 3. Semi-hard working stage           | Additional pitch (15°)  |
| 4. Hard finishing stage (burnishing) | Maximum pitch (20–25°)  |

### 4.14 Steering Controller Fault Codes

**Background** The steering system electronically converts the operator’s joystick movements into hydraulic force at the steering cylinders. An electronic controller located under the right hand machine lift point contains the control logic which runs the steering cartridge valves. Two LEDs (**a**, **b**) serve as visual indicators of steering system performance.

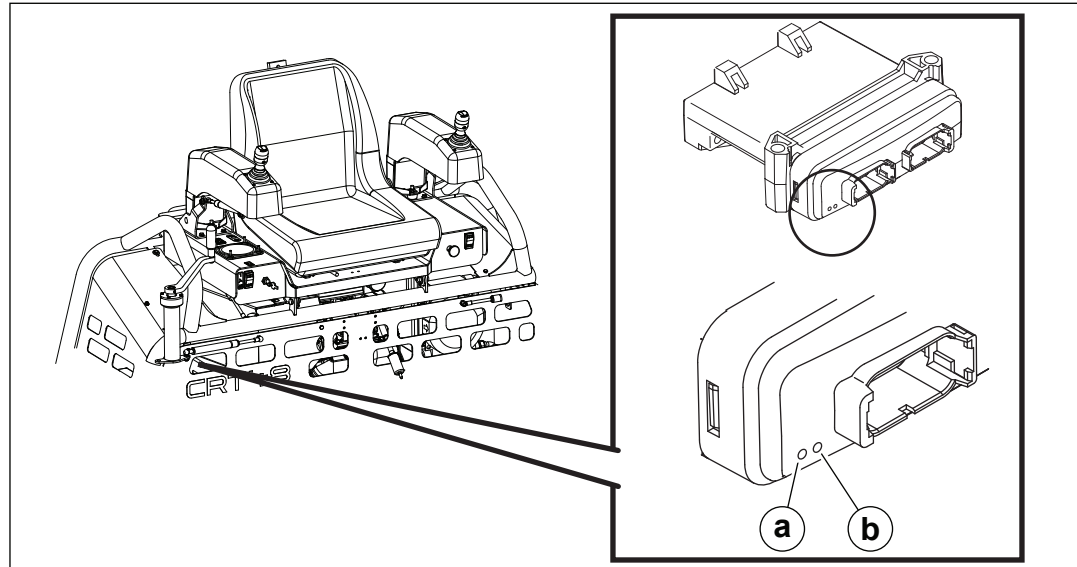

wc\_gr011859

**About fault codes** Fault codes communicate to the user if there is an electrical or electronic fault in the steering system. When the trowel is started, the electronic controller initializes and verifies circuit function.

- The green LED (**a**) illuminates and remains lit while the trowel is operating.
- The red LED (**b**) remains dark during normal operation. If a system fault occurs, the red LED flashes in sequence according to the fault codes described below.

**Identifying a fault code** A table of fault codes is listed in the table on the next page. To identify a fault code on the machine, count the number of times the red LED flashes and compare the number of flashes with those listed in the table.

- **Example:** A Y-axis right joystick fault is assigned Code 21. If this fault occurs on the machine, the red LED flashes twice, then once.

Flashing sequences repeat until the fault is corrected or the engine is stopped.

**Correcting fault codes** Perform the procedures below to correct a fault code.

1. Identify the fault code.
2. Verify that system voltage is within the proper 12-volt system range (11–14 volts).
3. Check for loose or disconnected electrical connections in the steering circuit. This includes both joystick connectors, both controller connectors, six cartridge valve connectors, and ground.
4. If system voltage is within range, and all electrical connections are tight, contact an authorized Wacker Neuson service center to correct the fault.

**Fault Codes**

| Code | Description   |
|------|---|
| 21   | Y-Axis Right joystick fault. Out of range.          |
| 22   | X-Axis Right joystick fault. Out of range.          |
| 23   | Y-Axis Left joystick fault. Out of range.           |
| 24   | Right rocker fault. Out of range.                   |
| 25   | Left rocker fault. Out of range.                    |
| 26   | R Right Coil disconnected, burnt out or overdriven. |
| 27   | R Left Coil disconnected, burnt out or overdriven.  |
| 28   | R FWD Coil disconnected, burnt out or overdriven.   |
| 29   | R REV Coil disconnected, burnt out or overdriven.   |
| 31   | L FWD Coil disconnected, burnt out or overdriven .  |
| 32   | L REV Coil disconnected, burnt out or overdriven.   |

### 4.15 Using the Work Lights

**Background** The machine is equipped with four work lights. The work lights are controlled by a single rocker switch below the left joystick.

The rocker switch **(a)** controls the front and rear work lights.

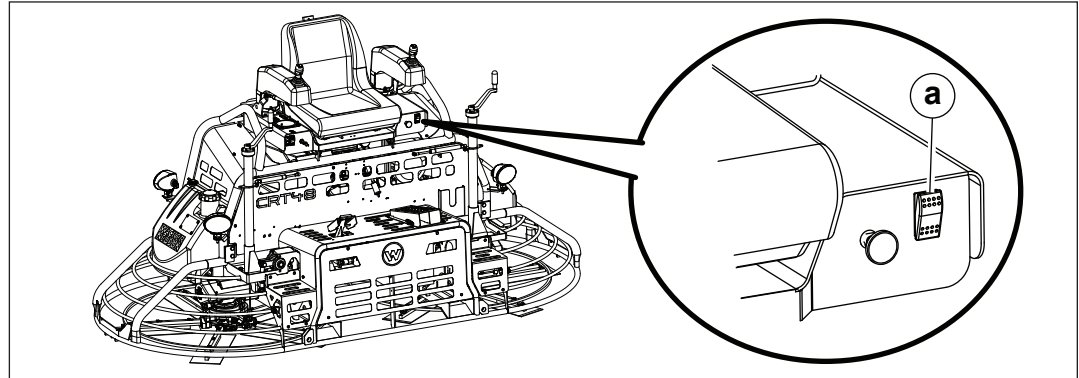

wc\_gr011861

## 4.16 Using the Retardant Spray System

- Requirements**
- Water/retardant in water tank
  - Ambient temperature above freezing

**Background** The retardant spray system is controlled by a switch located on the right joystick.

**Procedure** Perform the procedure below to operate the retardant spray system.

1. Fill the water tank with clean water or water-based retardant.
2. Open the valve **(a)**.

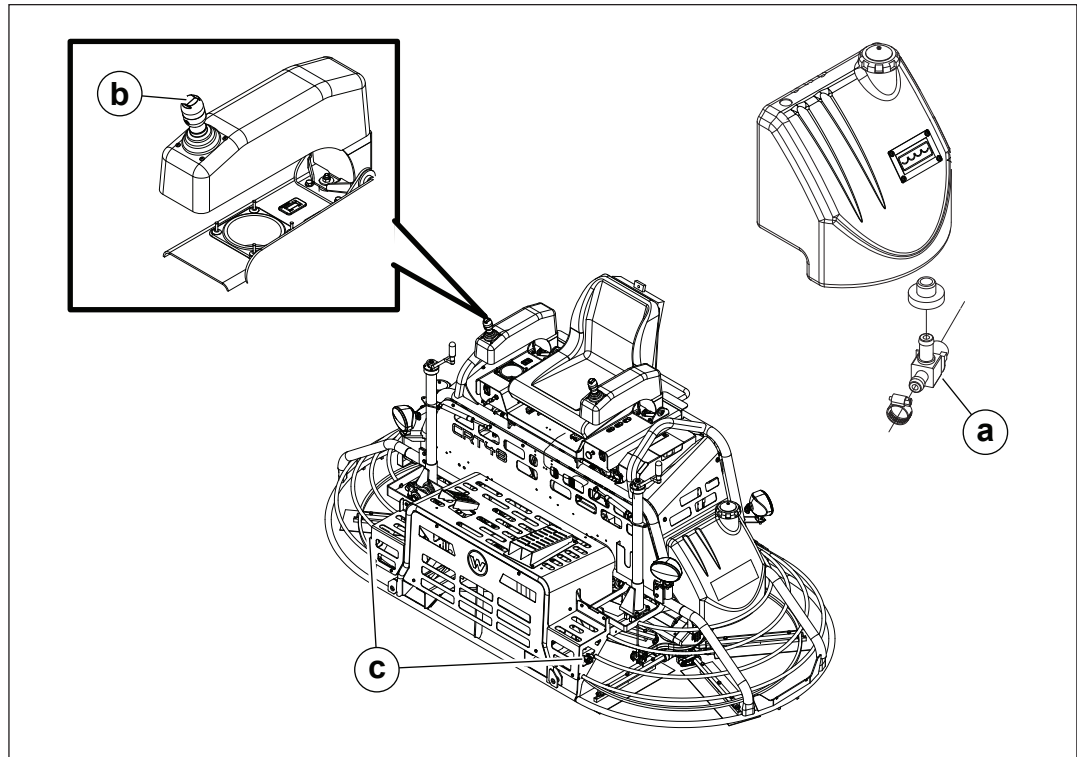

3. Press and hold the water spray switch **(b)** to activate the pump. The water/retardant will spray from the two nozzles **(c)**.

**NOTICE:** Drain the retardant spray system if the machine will be subject to temperatures below freezing. Frozen water or frozen retardant may damage the retardant spray system.

## 5 General Maintenance



---

**WARNING**

A poorly maintained machine can malfunction, causing injuries or permanent damage to the machine.

- ▶ Keep the machine in safe operating condition by performing periodic maintenance and making repairs as needed.
- 

### 5.1 Maintaining the Emission Control System

For machines sold in North America:

Normal maintenance, replacement, or repair of emission control devices and systems may be performed by any repair establishment or individual; however, warranty repairs must be performed by a dealer/service center authorized by Wacker Neuson. The use of service parts that are not equivalent in performance and durability to authorized parts may impair the effectiveness of the emission control system and may have a bearing on the outcome of a warranty claim.

**5.2 Periodic Maintenance Schedule**

The table below lists basic machine maintenance. Tasks designated with check marks ✓ may be performed by the operator. Tasks designated with square bullet points ■ require special training and equipment.

|  | Daily | Every 20 hours | Every 50 hours | Every 300 hours |
|--|-------|----------------|----------------|-----------------|
| Lubricate trowel arms.                             | ✓     |                |                |                 |
| Check external hardware.                           | ✓     |                |                |                 |
| Pressure wash all surfaces until free of concrete. | ✓     |                |                |                 |
| Check oil level in gearboxes.                      |       | ✓              |                |                 |
| Lubricate gearbox input shaft fitting.             |       | ■              |                |                 |
| Lubricate drive and pitch controls.                |       | ■              |                |                 |
| Check drive belt for wear.                         |       |                | ✓              |                 |
| Lubricate steering cylinder pivots.                |       |                | ■              |                 |
| Replace oil in gearboxes.                          |       |                |                | ■               |



### 5.3 Maintaining the Gearboxes

- When**
- ▶ Check the gearboxes for the correct oil level after every 20 hours of operation.
  - ▶ Change the gearbox oil every 300 hours.
  - ▶ Clear clogs from, or replace, pressure relief valve **(a)** as needed to prevent oil leakage from gearbox shaft seals.

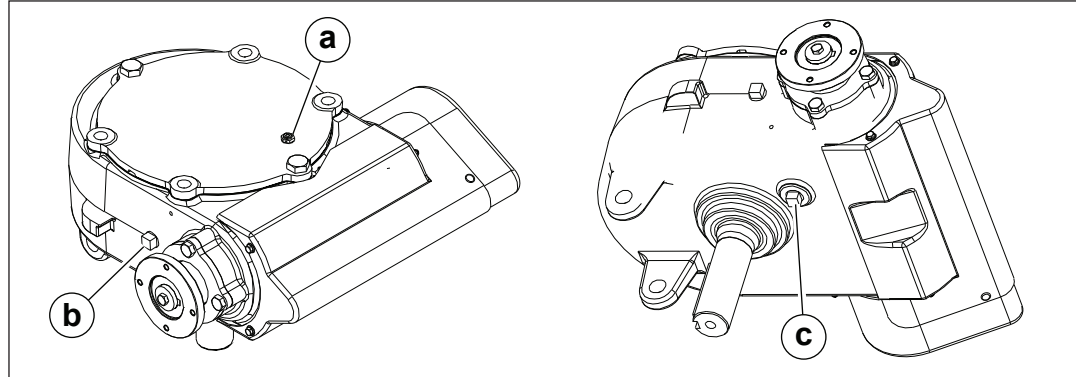

wc\_gr011863

- Requirements**
- Fresh oil (see *Technical Data* for quantity and type)
  - Plastic cloth and a container of sufficient volume to collect drained oil
- Note:** Collect, store and dispose of drained oil in accordance with current environmental protection regulations.



**WARNING**

Most used oil contains small amounts of materials that can cause cancer and other health problems if inhaled, ingested, or left in contact with skin for prolonged periods of time.

- ▶ Take steps to avoid inhaling or ingesting used engine oil.
- ▶ Wash skin thoroughly after exposure to used engine oil.

**Checking gearbox level**

Perform the procedure below to check the oil level.

1. Each CRT gearbox is equipped with two oil fill plugs **(b)**. Remove one gearbox oil fill plug.
2. If the level is below the threads of the oil fill plug hole, add synthetic gear oil through the opening. Do not overfill.
3. Wipe the threads dry on both the gearbox and the oil fill plug.
4. Apply Loctite 545 or equivalent to the oil fill plug threads, replace the oil fill plug and torque to 16–20 Nm (12–15 ft.lbs.).

**NOTICE:** Do not mix types of gear oil. Do not overfill the gearbox with oil. Damage to the gearbox may occur if oils are mixed, or if the gearbox is overfilled. See *Technical Data* for oil quantity and type.

**Changing gearbox oil**

Perform the procedure below to change the gearbox oil.

1. Place a container of sufficient capacity (approximately 3.8 L [1 gallon]) under each gearbox.
2. Remove the gearbox oil drain plug **(c)** and allow the oil to drain. It may be necessary to remove the gearbox oil fill plug(s) to facilitate draining.
3. After most of the oil has drained, tip the back of the trowel upwards to allow the remaining oil to drain.
4. After all the oil has drained, wipe the threads dry on both the gearbox and the oil drain plug.
5. Apply Loctite 545 or equivalent to the oil drain plug threads, and replace the gearbox oil drain plug.
6. With the trowel level, fill the gearbox with approximately 1.83 L (62 oz.) synthetic gear oil through the oil fill plug as described above.
7. Wipe the threads dry on both the gearbox and the oil fill plug.
8. Apply Loctite 545 or equivalent to the oil fill plug threads, replace the oil fill plug(s), and torque all plugs to 16–20 Nm (12–15 ft.lbs.).

### 5.4 Adjusting the Blade Arms

**When** Adjust the blade arms if the machine is wobbling during operation, after replacing an arm, or after disassembling the spider assembly.

- Requirements**
- Machine stopped
  - Lifting devices with enough weight-bearing capacity to lift the machine
  - Properly rated jack stands
  - Measuring device

- Procedure** Perform the procedure below to adjust the blade arms.
1. Using an appropriate hoist or crane, raise the machine off the ground so that the blades (at full pitch) will not touch the ground.
  2. Set the machine on four jack stands **(a)** as shown below.
  3. Using the pitch controls **(b)**, adjust the blades so that they are between 1/2 and full pitch (approximately 12°).

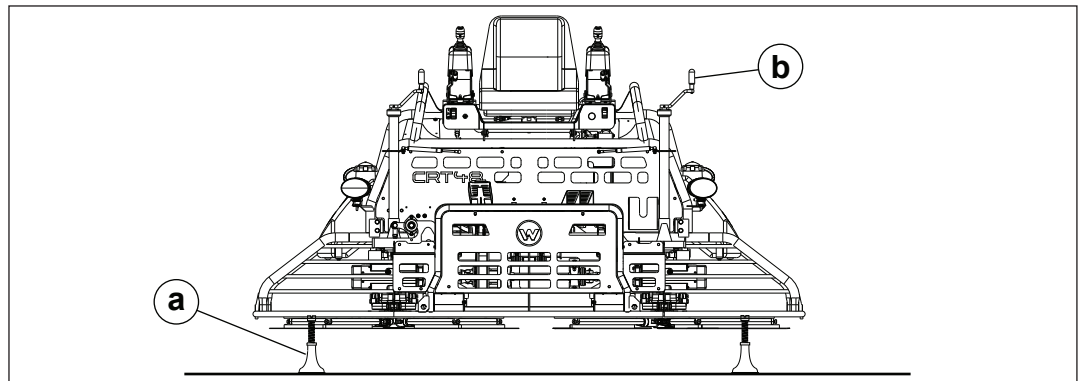

wc\_gr011864

4. Disconnect the battery.



**WARNING**

Cutting and pinch hazard.

- ▶ Disconnect the battery before measuring the blades.
- ▶ Wear hand protection when handling the blades.

*This procedure continues on the next page.*

Continued from the previous page.

- There is a small amount of play in the connection between the blade arm and the spider (lift plate). Gently wiggle each blade so that the lower end of the blade is at the lowest point of the play. Mark a reference point **(c)** on the machine frame. Measure the distance **(x)** between the machine frame at the reference mark and the bottom edge of the blade. Rotate the blades as necessary to measure the distance **(x)** for each blade.

**Note:** Rotate the blades by manually turning the drive belt.

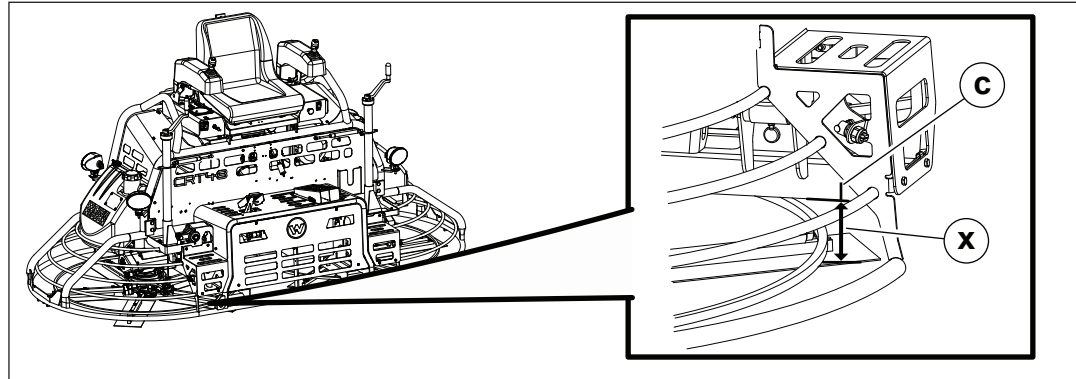

wc\_gr011867

- Determine the average distance “**x**”. Adjust any blade that does not measure the distance “**x** ± 1.25 mm (0.050 in.)”. To adjust: Loosen or tighten the pitch links **(d)** as necessary.

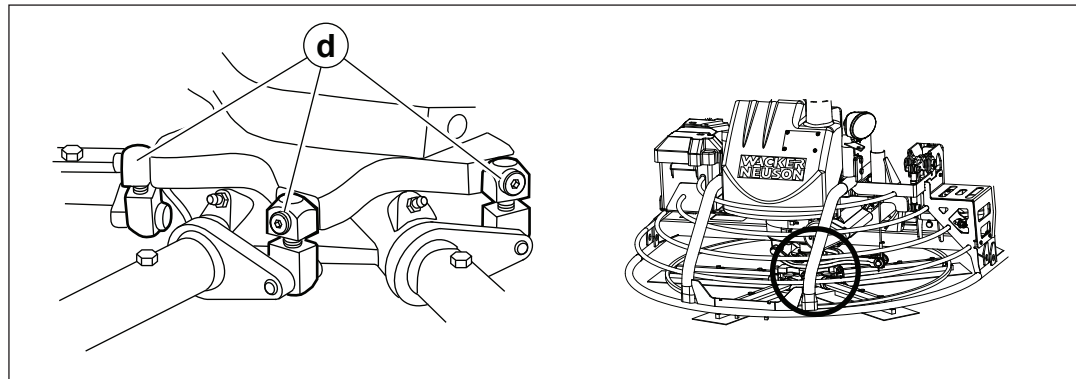

wc\_gr011868

- Reconnect the battery.

**Result**

The blade arms have now been adjusted.

### 5.5 Lubricate the Trowel Arms

- Requirements**
- Machine stopped
  - Grease (Unirex N2) or equivalent

**Procedure** Perform the procedure below to grease the trowel arms.

1. Set the trowel on a flat, level surface.
2. Disconnect the battery.
3. For access, pitch the blades to the maximum angle.
4. Apply grease to each zerk (**a**) on the spider assembly.

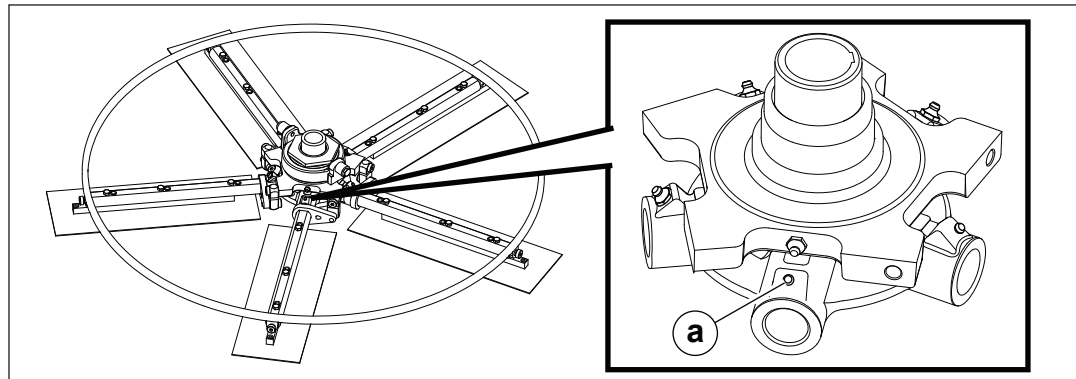

wc\_gr011908

5. Apply grease to the lifting ring (**b**) on each side of the machine.
- Note:** Graphic is representative only. Your machine may vary.

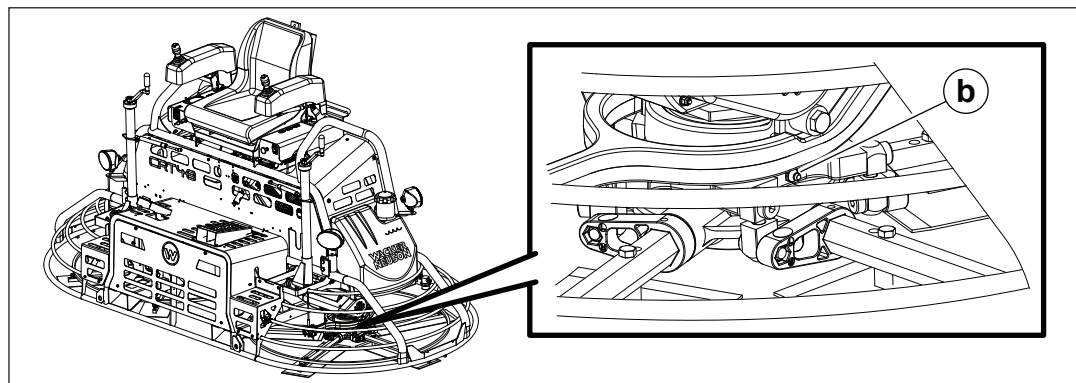

wc\_gr011909

**Result** The trowel arms have now been greased.

### 5.6 Mounting Float Pans

**Background** Certain applications may require the use of float pans. Optional float pans are available from your Wacker Neuson dealer. The blade arms on the machine are designed to accommodate either a standard 48" lip-style float pan or an optional smaller 46" pan. An alternative set of blade mounting holes is provided for mounting a 46" pan.

- Requirements**
- Machine stopped
  - Lifting devices with enough weight-bearing capacity to lift the machine
  - Properly rated jack stands

**Mounting a 48" float pan** Perform the procedure below to mount a 48" float pan.

1. Stop the engine.
2. Using an appropriate hoist or crane, raise the machine off the ground so that the blades will not touch the ground.
3. Set the machine on jack stands **(a)** as shown below.

**Note:** *Graphic is representative only. Your machine may vary.*

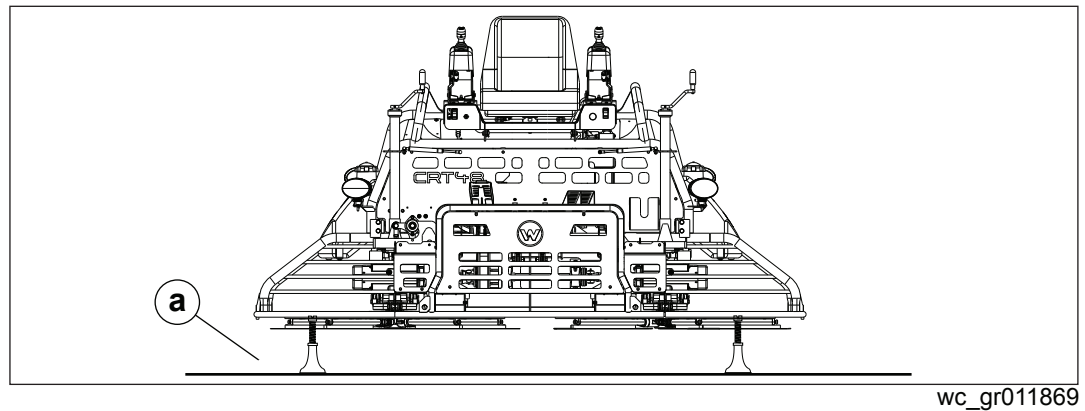

4. Position each float pan **(b)** against the blades, and turn the pans either left or right to engage clip angles **(c)** as shown.

**Note:** *Right-hand trowel blades turn counter-clockwise; left-hand trowel blades turn clockwise.*

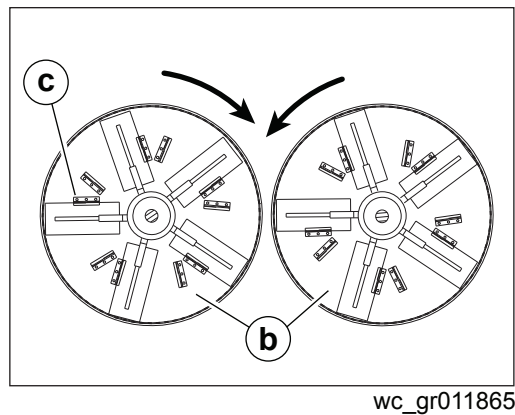

*This procedure continues on the next page.*

*Continued from the previous page.*

5. Lower the machine.



**WARNING**

Float pans can fall off a raised trowel, striking nearby personnel.

- ▶ Do not lift the trowel overhead after float pans have been mounted.

**Mounting a 46" float pan**

Perform the procedure below to mount a 46" float pan.

1. Loosen and remove the bolts (**d**) that attach each blade (**e**).

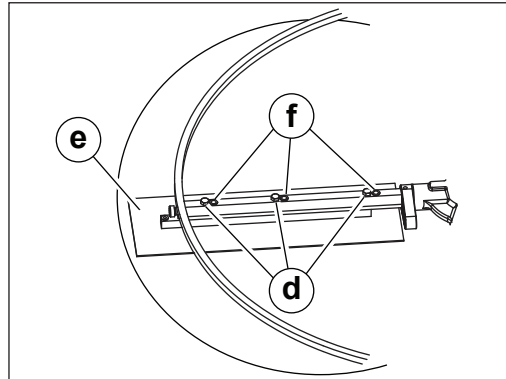

wc\_gr011866

2. Move the blades inward to align with mounting holes (**f**).
3. Re-install and tighten the bolts in mounting holes.
4. Attach the 46" pan to the blades.

### 5.7 Replacing the Drive Belt

- When**
- ▶ Check the drive belt every 50 hours
  - ▶ Replace the drive belt if it is worn or damaged.

- Requirements**
- Machine stopped
  - Replacement drive belt (in necessary)

- Procedure** Perform the procedure below to replace the drive belt.
1. Set the trowel on a flat, level surface with the blades pitched flat.
  2. Disconnect the battery.
  3. Remove the beltguard (a).
- Note:** *Graphic is representative only. Your machine may vary.*

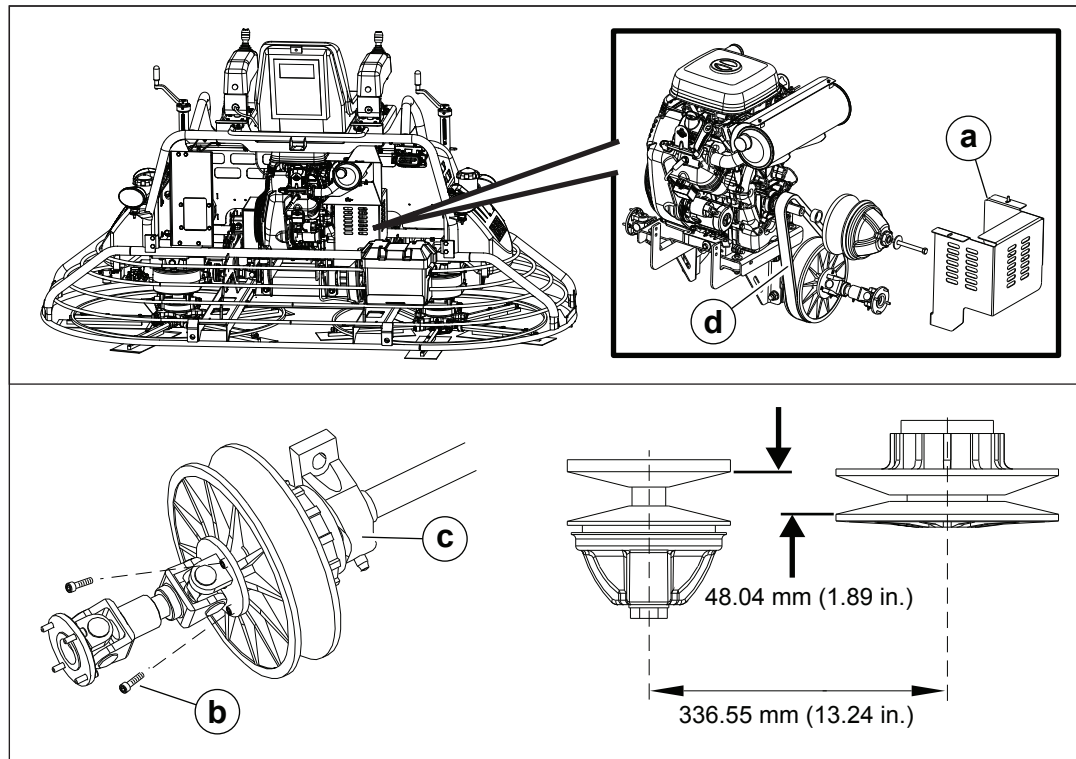

wc\_gr011871

4. Remove the three bolts (b) holding the universal joint to the drive pulley.
5. Loosen the pillow block bearing (c).
6. Remove the old drive belt (d).
7. Install a new drive belt.



- Reassembly**     Perform the procedure below to reassemble the belt drive.
1. Align the pillow bearing and shaft as straight as possible. Adjust pulley offset and center distance to values as shown.
  2. Re-install the three bolts and torque to  $14 \pm 1.4$  Nm ( $10 \pm 1$  ft.lbs.).
  3. Re-install the beltguard.
  4. Reconnect the battery.
- 
- Result**     The drive belt has now been replaced.

## 5.8 Installing or Changing the Blades

**Introduction** There are two types of blades available for the trowel:

- Combination blades can be used throughout the entire concrete working process, from floating to finishing stages. They are designed for rotation in one direction only.
- Finish blades are used only in the final stages of the concrete working process. While in use, these blades are pitched at progressively steeper angles to burnish the concrete. Finish blades are symmetrical and can be installed to rotate in either direction.

**Requirements**

- Machine is stopped
- Battery is disconnected to prevent unintentional start-up
- Machine has been lifted via a hoist, or raised on the wheel kit.
- Frame is supported on blocks while the machine is elevated.
- Combination blades or finish blades for installation
- Protective gloves
- Bearing grease



**WARNING**

Cutting hazard. Trowel blade edges are extremely sharp, especially if worn.

- ▶ Always wear protective gloves when changing blades.

**Procedure**

Perform the procedure below to install or change the blades.

1. Remove the screws (a) from the trowel arms (b) and detach the existing blades (c). Set the existing blades aside for future use or dispose of them properly if they have reached the end of their service life.

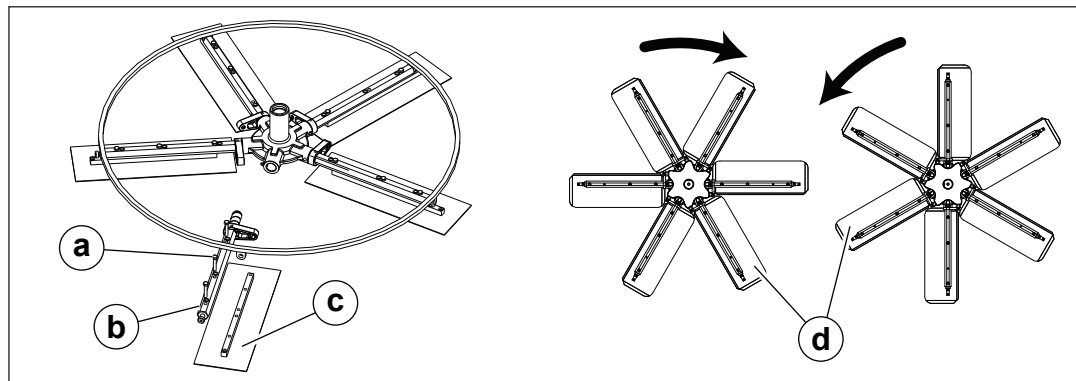

wc\_gr011872

*This procedure continues on the next page.*

*Continued from the previous page.*

2. Position and align the blades.
    - If installing combination blades (**d**), orient the blades as shown in the diagram and align the screw holes. This positions the raised edge of each blade correctly for the rotation of each rotor.
    - If installing finish blades, simply align the screw holes. Blade orientation is not critical with finish blades.
  3. Coat the screw threads with bearing grease. A grease coating will prevent wet concrete from cementing the screws in place. This step will also make blade removal easier in the future.
  4. Re-install the screws and tighten securely. Do not overtighten.
- 

**Result**

The blades have now been changed.

## 5.9 Cleaning the Machine

**When** Clean the machine after each use.

---

**Background** Regular cleaning is essential for keeping the trowel in serviceable condition. It is important to remove uncured concrete, dust and dirt from the trowel as soon as possible after work has been completed.

---

**Requirements**

- Engine stopped and machine cool to the touch
- Fresh, clean water supply
- Pressure washer
- Clean, soft cloths

---

**Procedure** Perform the procedure below to clean the machine.

1. Use a pressure washer to remove concrete and debris from the trowel blades, wheels, and ring guards.
2. Keeping a minimum distance of 1 meter (3 feet) away, use the pressure washer to rinse the trowel body.

**NOTICE:** Direct, high water pressure at close range will damage certain components on the machine. The following components should be wiped clean by hand using a damp, clean cloth. Do not apply high pressure spray to these components:

- Oil cooler, fan, and connecting hoses
- Operator's station including the seat, joysticks/control levers, control switches, key switch, indicator lights, and throttle control
- Foot pedal
- Hydraulic manifold
- Fuse boxes
- Electronic controller
- Electrical connectors

## 5.10 Storage

Extended storage of equipment requires preventive maintenance. Performing these steps helps to preserve machine components and ensures the machine will be ready for future use. While not all of these steps necessarily apply to this machine, the basic procedures remain the same.

---

**When** Prepare your machine for extended storage if it will not be operated for 30 days or more.

---

**Preparing for storage** Perform the procedures below to prepare your machine for storage.

- Complete any needed repairs.
- Replenish or change oils (engine, exciter, hydraulic, and gearcase) per the intervals specified in the Scheduled Maintenance table.
- Grease all fittings and, if applicable, repack bearings.
- Inspect engine coolant. Replace coolant if it appears cloudy, is more than two seasons old, or does not meet the average lowest temperature for your area.
- If your machine has an engine equipped with a fuel valve, start the engine, close the fuel valve, and run the engine until it stops.
- Consult the engine owner's manual for instructions on preparing the engine for storage.

---

**Stabilizing the fuel** After completing the procedures listed above, fill the fuel tank completely and add a high-quality stabilizer to the fuel.

- Choose a stabilizer that includes cleaning agents and additives designed to coat/protect the cylinder walls.
- Make sure the stabilizer you use is compatible with the fuel in your area, fuel type, grade, and temperature range. Do not add extra alcohol to fuels which already contain it (for example, E10).
- For engines with diesel fuel, use a stabilizer with a biocide to restrict or prevent bacteria and fungus growth.
- Add the correct amount of stabilizer per the manufacturer's recommendations.

---

**Storing the machine** Perform these remaining steps to store your machine.

- Wash the machine and allow it to dry.
- Move the machine to a clean, dry, secure storage location. Block or chock the wheels to prevent machine movement.
- Use touch-up paint as needed to protect exposed metal against rust.
- If the machine has a battery, either remove or disconnect it.

**NOTICE:** Allowing the battery to freeze or completely discharge is likely to cause permanent damage. Periodically charge the battery while the machine is not in use. In cold climates, store and charge the battery indoors or in a warm location.

- Cover the machine. Tires and other exposed rubber items should be protected from the weather. Either cover them or use a protectant.

## 5.11 Machine Disposal / Decommissioning

**Introduction** This machine must be properly decommissioned at the end of its service life. Responsible disposal of recyclable components, such as plastic and metal, ensures that these materials can be reused—conserving landfill space and valuable natural resources.

Responsible disposal also prevents toxic chemicals and materials from harming the environment. The operating fluids in this machine, including fuel, engine oil, and grease, may be considered hazardous waste in many areas. Before decommissioning this machine, read and follow local safety and environmental regulations pertaining to the disposal of construction equipment.

---

**Preparation** Perform the following tasks to prepare the machine for disposal.

- Move the machine to a protected location where it will not pose any safety hazards and cannot be accessed by unauthorized individuals.
- Ensure that the machine cannot be operated from the time of final shutdown to disposal.
- Drain all fluids, including fuel, engine oil, and coolant.
- Seal any fluid leaks.
- Remove the battery.

---

**Disposal** Perform the following tasks to dispose of the machine.

- Disassemble the machine and separate all parts by material type.
- Dispose of recyclable parts as specified by local regulations.
- Dispose of all non-hazardous components that cannot be recycled.
- Dispose of waste fuel, engine oil, and hydraulic fluid in accordance with local environmental protection regulations.

### 6 Engine Maintenance: KOHLER

The information in this chapter comes from copyrighted Kohler material.

The viscosity of the engine oil is an important factor when determining the correct engine oil to use in your machine. Use an engine oil of appropriate viscosity based on the expected outside air temperature. See the table below.



---

**WARNING**

Most used liquids from this machine such as oil, gasoline, grease, etc., contain small amounts of materials that can cause cancer and other health problems if inhaled, ingested, or left in contact with skin for prolonged periods of time.

- ▶ Take steps to avoid inhaling or ingesting used liquids.
  - ▶ Wash skin thoroughly after exposure to used liquids.
-

OIL CLASSIFICATIONS API/MIL - SEQUENZE API/MIL - SEQUENCES API/MIL  
 API/MIL-SEQUENZEN - SECUENCIAS API/MIL - SEQUENCIAS API/MIL

|     |     | DIESEL |      |      |      |    |    |    |    |    |    |    | GASOLINE - BENZINA - ESSENCE<br>BENZIN - GASOLINA |    |    |    |    |  |  |  |  |  |  |
|-----|-----|--------|------|------|------|----|----|----|----|----|----|----|---|----|----|----|----|--|--|--|--|--|--|
| API | MIL | CH-4   | CG-4 | CF-4 | CF-2 | CF | CE | CD | CC | SC | SD | SE | SF  | SG | SH | SJ | SL |  |  |  |  |  |  |
|     |     |        |      |      |      |    |    |    |    |    |    |    |   |    |    |    |    |  |  |  |  |  |  |
|     |     |        |      |      |      |    |    |    |    |    |    |    |   |    |    |    |    |  |  |  |  |  |  |
|     |     |        |      |      |      |    |    |    |    |    |    |    |   |    |    |    |    |  |  |  |  |  |  |
|     |     |        |      |      |      |    |    |    |    |    |    |    |   |    |    |    |    |  |  |  |  |  |  |
|     |     |        |      |      |      |    |    |    |    |    |    |    |   |    |    |    |    |  |  |  |  |  |  |
|     |     |        |      |      |      |    |    |    |    |    |    |    |   |    |    |    |    |  |  |  |  |  |  |
|     |     |        |      |      |      |    |    |    |    |    |    |    |   |    |    |    |    |  |  |  |  |  |  |
|     |     |        |      |      |      |    |    |    |    |    |    |    |   |    |    |    |    |  |  |  |  |  |  |
|     |     |        |      |      |      |    |    |    |    |    |    |    |   |    |    |    |    |  |  |  |  |  |  |

L-46152 D/E

CURRENT - CORRENTI OBSOLETE - OBSOLETI

SAE Viscosity Grade - Gradazioni SAE - Viscosité SAE  
 SAE Viskositätsklasse - Viscosidad SAE - Gradação SAE

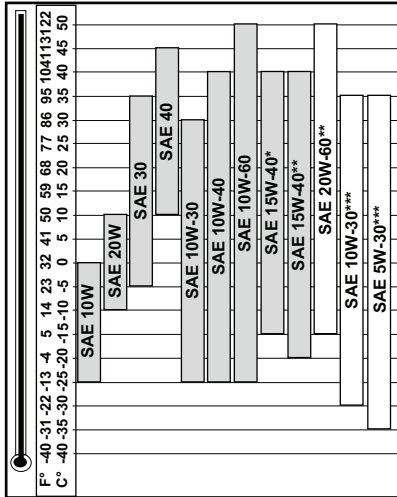

\*

Mineral Base  
 Base Minerale  
 Base Minérale  
 Mineralölbasis  
 Base Mineral  
 Base Mineral

\*\*

Semi-Synthetic Base  
 Base Semi-Sintética  
 Base Semi-Synthétique  
 Halbsynthetische Basis  
 Base Semi-Sintética  
 Base Semi-Sintética

\*\*\*

Synthetic Base  
 Base Sintética  
 Base Synthétique  
 Synthetische Basis  
 Base Sintética  
 Base Sintética

770005



The engine maintenance schedule(s) in this chapter are reproduced from the engine owner's manual. For additional information, see the engine owner's manual.

| <b>KOHLER®</b><br>ORDINARY MAINTENANCE - MANUTENZIONE ORDINARIA<br>ENTRETIEN ORDINAIRE - ORDENTLICHE WARTUNG<br>MANUTENCION ORDINARIA - MANUTENÇÃO NORMAL   |      | CHECK - CONTROLLO - CONTRÔLE - KONTROLLE - COMPROBACION - CONTRÔLE   |     |  |     |      |      |       |
|---|------|--|-----|--|-----|------|------|-------|
|   |      | OPERATION DESCRIPTION - DESCRIZIONE OPERAZIONE<br>DESCRIPTION DE L'OPERATION - BESCHREIBUNG DES ARBEITSVORGANGS<br>DESCRIPCIÓN DE LA OPERACIÓN - DESCRIÇÃO DA OPERAÇÃO |     | FREQUENCY x HOURS - PERIODICITA' x ORE<br>FREQUENCIA x HEURES - WARTUNGSPERIODEN x STUNDEN<br>PERIODO x HORAS - FREQUÊNCIA x HORAS |     |      |      |       |
|   |      | 10   | 250 | 300  | 500 | 1000 | 5000 | 10000 |
| Oil Level - Livello Olio Motore - Niveau huile Moteur - Ölstanddaten - Nivel Aceite Del Motor - Nivel Óleo do Motor   |      |  |     |  |     |      |      |       |
| Coolant Level - Livello Liquido di Raffreddamento - Niveau Liquide Réfrigérant - Kühlfüssigkeitsstands - Nivel Liquido para Refrigeración - Nivel Liquido Esfriamento.  |      |  |     |  |     |      |      |       |
| Radiator Core - Superficie di Scambio Radiatore - Surface d'Échange radiateur - Austauschfläche des Kühlers - Superficie de Intercambio del Radiador - Superficie de Troca do Radiador                        |      |  |     |  |     |      |      |       |
| Panel Air Filter (Dry-Type) - Filtro Aria a Pannello (a Secco) - Filtre à Air à Panneau (à Sec) - Plattenluftfilter (Trocken) - Filtro de Aire de Panel (a Seco) - Filtro de Ar de Painel (a Seco)            | (**) |  |     |  |     |      |      |       |
| Remote Air Filter (Dry-Type) - Filtro Aria a Distanza (a Secco) - Filtre à Air à Distance (à Sec) - Luftfilter Mit Abstand (Trocken) - Filtro de Aire Remoto (a Seco) - Filtro de ar a Distância (a Seco)     | (**) |  |     |  |     |      |      |       |
| Fuel Lines - Tubi Carburante - Tuyaux Combustible - Kraftstoffleitungen - Tubos de Combustible - Tubos Combustíveis   |      |  |     |  |     |      |      |       |
| Fan/Alternator Belt Tension - Tensione Cinghia Ventola/Alternatore - Tension Courroie Ventilateur/Alternateur Keilriemens Lüfter - Tension Correa Ventilador/Alternador - Tensão Cincha Ventilador/Alternador | (*)  |  |     |  |     |      |      |       |

(\*\*\*) - Check paper element for dirty, loose, or damaged parts, in accordance with the maintenance schedule. Depending on the environment the engine is used in, clean and replace filter more often, especially in dusty, dirty conditions.

- Il periodo di tempo che deve intercorrere prima di pulire o sostituire l'elemento filtrante è subordinato all'ambiente in cui opera il motore. In condizioni ambientali molto polverose il filtro dell'aria deve essere pulito e sostituito più spesso.
- Le temps qui doit s'écouler avant de nettoyer ou de remplacer l'élément filtrant dépend des conditions dans lesquelles le moteur tourne. Nettoyer et remplacer plus souvent le filtre à air doit quand le milieu est très poussiéreux.
- Das Zeitintervall zwischen den Reinigungen oder dem Auswechseln des Filterelements hängt von der Umgebung ab, in der der Motor verwendet wird. In sehr staubiger Umgebung muss der Luftfilter öfter gereinigt und ausgetauscht werden.
- El intervalo de tiempo que debe transcurrir antes de limpiar o sustituir el elemento filtrante depende del ambiente de funcionamiento del motor. En ambientes muy polvorientos el filtro de aire debe ser limpio y debe sustituirse más a menudo.
- O período de tempo que há de passar antes de limpar ou substituir o elemento filtrante está subordinado ao ambiente em que o motor trabalha. Em condições ambientais muito poeirentas o filtro do ar deve ser limpo e substituído muitas vezes.

770002

| CHECK - CONTROLLO - CONTRÔLE - KONTROLLE - COMPROBACION - CONTRÔLE  |  |     |     |     |      |      |       |
|---|--|-----|-----|-----|------|------|-------|
| OPERATION DESCRIPTION - DESCRIZIONE OPERAZIONE<br>DESCRIPTION DE L'OPÉRATION - BESCHREIBUNG DES ARBEITSVORGANGS<br>DESCRIPCIÓN DE LA OPERACIÓN - DESCRIÇÃO DA OPERAÇÃO  | FREQUENCY x HOURS - PERIODICITÀ x ORE<br>FREQUENCE x HEURES - WARTUNGSPERIODEN x STUNDEN<br>PERIODO x HORAS - FREQUÊNCIA x HORAS |     |     |     |      |      |       |
|   | 10   | 250 | 300 | 500 | 1000 | 5000 | 10000 |
| Cooling Hoses - Manicotti Liquido di Raffreddamento - Manchons de Liquide de Refroidissement - Muffen des Kühlmittels - Manguitos de Liquido de Refrogeración - Casquilhos para Liquido de Arrefecimento  |  |     |     |     |      |      |       |
| Rubber Intake Hose (Air Filter and Intake Manifold) for Engines with Remote Air Filter - Tubo in Gomma Asp. (Filtro Aria Coll. Asp.) Per Mot. Con Filtro Aria a Dist. - Tuyau d'Aspiration en Caoutchouc (Filtre à Air du Collecteur d'Admission) Pour Mot. Avec Système de Filtrage d'Air à Distance - Gummiansaugschlauch (Luftfilter Ansaugkrümmer) Für Mot. Mit Luftfilter Mit Abstand - Tubo de Goma de Dimensión (Filtro de Aire Colector de Admisión) Para Mot. Con Filtro de Aire Remoto - Tubo de Borracha de Aspiração (Filtro ar Colector de Aspiração) Para Mot. com Filtro de ar a Distância |  |     |     |     |      |      |       |
| Valve Clearance - Registro Gioco Valvole - Réglage Jeu Soupapes - Einstellen des Ventilspiels Ajuste da Tolarância - Registro Juego de Válvulas - Apuramento válvula  |  |     |     |     |      |      |       |
| Injector Cleaning and Adjustment - Taratura e Pulizia Iniettori - Tarage et Nettoyage Injecteur Einspritzdüsen Überprüfen - Ajuste y Limpieza Inyectores - Taradura e Limpeza Injettores  |  |     |     |     |      |      |       |
| Flush Radiator - Pulizia Interna Radiatore - Nettoyage Intérieur du Radiateur - Innenreinigung des Kühlers - Limpeza del Interior del Radiador - Limpeza Interna do Radiador  |  |     |     |     |      |      |       |
| Clean Fuel Tank - Pulizia Serbatoio Combustibile - Nettoyage du Réservoir à Combustible - Reinigung Kraftstofftank - Limpeza Depósito Combustible - Limpeza do Depósito do Combustível  |  |     |     |     |      |      |       |

770003

| REPLACEMENT - SOSTITUZIONE - REMPLACEMENT - AUSWECHSELN - SUBSTITUTION - SUBSTITUIÇÃO  |  |     |     |     |      |  |
|--|--|-----|-----|-----|------|--|
| OPERATION DESCRIPTION - DESCRIZIONE OPERAZIONE<br>DESCRIPTION DE L'OPERATION - BESCHREIBUNG DES ARBEITSVORGANGS<br>DESCRIPCIÓN DE LA OPERACION - DESCRIÇÃO DA OPERAÇÃO   | FREQUENCY x HOURS - PERIODICITA' x ORE<br>FREQUENCIA x HEURES - WARTUNGSPERIODEN x STUNDEN<br>PERIODO x HORAS - FREQUENCIA x HORAS |     |     |     |      |  |
|  | 10   | 250 | 300 | 500 | 1000 | 5000   |
| Engine Oil (*) - Olio Motore (*) - Huile Moteur (*) - Öldaten (*) - Aceite del Motor (*) - Óleo do Motor (*)   | (*)  |     |     |     |      | 10000  |
| Oil Filter - Filtro Olio - Filtre a Huile - Öl Filter - Filtro Aceite - Filtro Óleo  | (*)  |     |     |     |      |  |
| Fuel Filter - Filtro Combustibile - Filtre a Combustible - Brennstofffilter - Filtro Combustível   | (*)  |     |     |     |      |  |
| Alternator Belt - Cinghia Alternatore - Courroie Alternateur - Drehstromgenerator Riemen - Correa Alternador - Cincha Alternador   | (**)   |     |     |     |      |  |
| Coolant - Liquido di Raffreddamento - Liquide Refrigerant - Kühflüssigkeit - Liquido de Refrigeración - Líquido Esfriamento  | (**)   |     |     |     |      |  |
| Fuel Lines - Tubi Carburante - Tuyaux Combustible - Kraftstoffleitungen - Tubos de Combustible - Tubos Combustíveis  | (**)   |     |     |     |      |  |
| Rubber Intake Hose (Air Filter and Intake Manifold) - Tubo in Gomma Asp. (Filtro Aria Coll. Asp.) - Tuyau d'aspir. en Caoutchouc (Filtre à Air du Coll. d'Admiss.) - Gummiansaugschlauch (Luftfilter Ansaugtrümmer) - Tubo de Goma de Admis. (Filtro de Aire Col. De Admis.) - Tubo de Borracha de Aspir. (Filtro ar Col. de Aspir.) | (**)   |     |     |     |      |  |
| Coolant Hoses - Manicotti Liquido di Raffredd. - Manchons de Liquide de Refroid. - Muffen des Kühlmittels - Manguitos de Líquido de Refrig. - Casquilhos para Líquido de Arrefecimento   | (**)   |     |     |     |      |  |
| Timing Belt - Cinghia Distribuzione - Courroie de Distribution - Verteilerriemen Corree de Distribuição - Correia de Distribuição  | (***)  |     |     |     |      | Every 4000 hours or 4 Years - Ogni 4000 ore o 4 anni - Toutes les 4000 heures ou 4 ans - Alle 4000 Stunden und 4 Jahre - Cada 4000 horas o 4 anos - Cada 4000 oras o 4 anos                          |
| Dry Air Cleaner, External Cartridge - Cartuccia Esterna Filtro Aria a Secco - Cartouche Extérieure Filtre a Air Desséchée - Äusserer Trockenluftfiltersatz - Cartucho Externo del Filtro de Aire Seco - Cartucho Externo Filtro ar A Seco  | (****)   |     |     |     |      |  |
| Filter Element, Panel Air Filter - Massa Filtrante Filtro Aria a Pannello - Masse Filtrante de Filtre à Air à Panneau Filtrerelement Plattenluftfilter - Masa Filtrante del Filtro de Aire de Panel - Massa Filtrante do Filtro de ar de   |  |     |     |     |      | After six cleaning checks - Dopo 6 Controlli con Pulizia - Au Bout de 6 Contrôles Avec Nettoyage - Nach 6 Kontrollen Mit Reinigung - Tras 6 Inspecciones Con Limpieza - Após 6 Controlos com Limpeza |

- (°) - If you are using oil of a quality lower than the prescribed one then you will have to replace it every 125 hours for the standard sump and every 150 hours for the enhanced sump.
- Se si utilizza olio di qualità inferiore a quello prescritto sostituirlo ogni 125 ore per la coppa standard e 150 per la coppa maggiorata.
  - Si l'huile utilisée est de qualité inférieure à celle indiquée, la vindanger toutes les 125 heures s'il s'agit d'un carter surdimensionné.
  - Wenn Öl einer niedrigeren Qualität als vorgeschrieben verwendet wird, sollte es bei Standardölwannen alle 125 Betriebsstunden, bei vergrößerten Ölwannen alle 150 Stunden gewechselt werden.
  - Si se utiliza un aceite de calidad inferior al que recomendado deberá sustituirse cada 125 horas en caso de cárter estándar o cada 150 en caso de cárter sobredimensionado.
  - Se utilizar óleo de qualidade inferior à queles prescrito, substitua-o a cada 125 horas para o cárter padrao e 150 para o cárter aumentado.

770004

# Engine Maintenance: Vanguard

## 7 Engine Maintenance: Vanguard

The information in this chapter comes from copyrighted Vanguard material.

The viscosity of the engine oil is an important factor when determining the correct engine oil to use in your machine. Use an engine oil of appropriate viscosity based on the expected outside air temperature. See the table below.



### WARNING

Most used liquids from this machine such as oil, gasoline, grease, etc., contain small amounts of materials that can cause cancer and other health problems if inhaled, ingested, or left in contact with skin for prolonged periods of time.

- ▶ Take steps to avoid inhaling or ingesting used liquids.
- ▶ Wash skin thoroughly after exposure to used liquids.

### Oil Recommendations

We recommend the use of Briggs & Stratton Warranty Certified oils for best performance. Other high-quality detergent oils are acceptable if classified for service SF, SG, SH, SJ or higher. Do not use special additives.

Outdoor temperatures determine the proper oil viscosity for the engine. Use the chart to select the best viscosity for the outdoor temperature range expected.

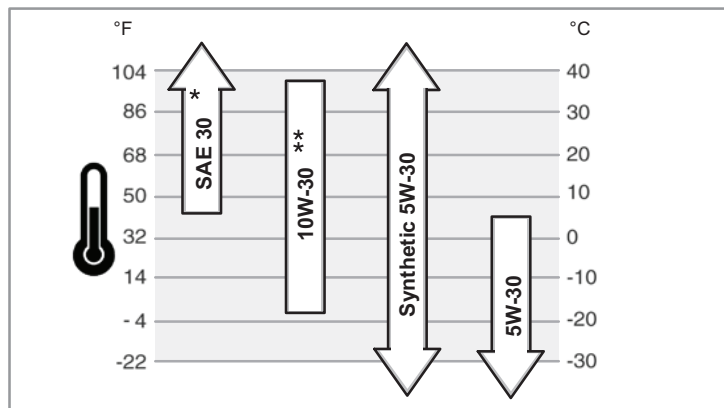

\* Below 40°F (4°C) the use of SAE 30 will result in hard starting.

\*\* Above 80°F (27°C) the use of 10W-30 may cause increased oil consumption. Check oil level more frequently.

770026

The engine maintenance schedule(s) in this chapter are reproduced from the engine owner's manual. For additional information, see the engine owner's manual.

## Maintenance Chart

|  |
|--|
| <b>First 5 Hours</b>   |
| Change oil   |
| <b>Every 8 Hours or Daily</b>  |
| Check engine oil level<br>Clean area around muffler and controls   |
| <b>Every 100 Hours or Annually</b>   |
| Clean or change air filter * ▲<br>Change engine oil and filter<br>Clean pre-cleaner (if equipped)*<br>Replace spark plug<br>Check muffler and spark arrester |
| <b>Every 250 Hours or Annually</b>   |
| Check valve clearance. Adjust if necessary.  |
| <b>Every 400 Hours or Annually</b>   |
| Change air filter ▲<br>Replace fuel filter<br>Clean air cooling system*<br>Clean oil cooler fins*  |
| <b>Every 600 Hours or Annually</b>   |
| Change safety filter (if equipped)   |

\* In dusty conditions or when airborne debris is present, clean more often.

▲ Every third air filter change, change the inner safety filter (if equipped).

770027

## 8 Engine Maintenance: Kubota

The information in this chapter comes from copyrighted Kubota material.

The viscosity of the engine oil is an important factor when determining the correct engine oil to use in your machine. Use an engine oil of appropriate viscosity based on the expected outside air temperature. See the table below.



### WARNING

Most used liquids from this machine such as oil, gasoline, grease, etc., contain small amounts of materials that can cause cancer and other health problems if inhaled, ingested, or left in contact with skin for prolonged periods of time.

- ▶ Take steps to avoid inhaling or ingesting used liquids.
- ▶ Wash skin thoroughly after exposure to used liquids.

### IMPORTANT :

- Engine oil should have properties of API classification SL or higher.
- Change the type of engine oil according to the ambient temperature.

|                             |                                 |
|-----------------------------|---------------------------------|
| Above 25°C (77°F)           | SAE30 or SAE10W-30<br>SAE15W-40 |
| 0°C to 25°C (32°F to 77°F)  | SAE20 or SAE10W-30              |
| 0°C to -20°C (32°F to -4°F) | SAE10W or SAE10W-30             |

- When using oil of different brands from the previous one, be sure to drain all the previous oil before adding the new engine oil.

770083

# Engine Maintenance: Kubota

The engine maintenance schedule(s) in this chapter are reproduced from the engine owner's manual. For additional information, see the engine owner's manual.

## SERVICE INTERVALS

Non-warranty maintenance, repair, or replacement of the emission control devices and systems should be performed by a qualified repair establishment or individual which has the experience and equipment to perform such work. See the Emission Warranty Statement.

In order to keep your engine in good working conditions, be sure to follow the maintenance / checking schedule given in the table below. (The schedule applies to an engine in use under normal conditions.)

| Items   |                     | Interval              |                         |                 |                 | Remarks       |
|---|---------------------|-----------------------|-------------------------|-----------------|-----------------|---------------|
|   |                     | Every 8 hours (daily) | Every 50 hours (weekly) | Every 100 hours | Every 200 hours |               |
| Each part   | Check / Clean       | ●                     |                         |                 |                 |               |
| Engine oil  | Check / Replenish   | ●                     |                         |                 |                 |               |
|   | Change              |                       | (Initial change)        |                 | ●               |               |
| Oil filter cartridge  | Change              |                       | (Initial change)        |                 | ●               |               |
| Spark plug  | Clean               |                       |                         | ▲               |                 |               |
|   | Adjust              |                       |                         | ▲               |                 |               |
|   | Change              |                       |                         |                 |                 |               |
| Air cleaner element   | Check               | ▲                     |                         |                 |                 |               |
|   | Clean               | ▲                     |                         | ●               |                 |               |
|   | Change              |                       |                         |                 |                 |               |
| Intake pipe / clamp bands   | Change              |                       |                         |                 |                 |               |
| Fuel filter   | Check               |                       |                         | ●               |                 |               |
|   | Change              |                       |                         | ▲               |                 |               |
| Fuel tank   | Clean               |                       |                         |                 |                 | Gasoline line |
|   | Check setting       | ▲                     |                         |                 | ●               | LPG line      |
| Fuel pipe / clamps (Gasoline line)                                | Check               |                       | ●                       |                 |                 |               |
|   | Change              |                       |                         |                 |                 |               |
| Fuel pipe / clamps (LPG line: LPG tank to regulator assy (D-EPR)) | Check the connector | ●                     |                         |                 |                 |               |
|   | Check fuel leakage  |                       | ●                       |                 |                 |               |
|   | Change              |                       |                         |                 |                 |               |

▲: If necessary

### IMPORTANT:

\*1 Change more often when operating under dusty conditions.

\*2 If you do not have the proper tools and/or are not mechanically proficient, contact your local KUBOTA dealer.

To ensure the best quality and reliability, use new KUBOTA Genuine parts or their equivalents for repair and replacement, whenever you have maintenance done.

770084

# Engine Maintenance: Kubota

| Items   |                     | Interval         |                  |        |              | Remarks       |
|---|---------------------|------------------|------------------|--------|--------------|---------------|
|   |                     | Every 1000 hours | Every 2000 hours | Yearly | Each 2 years |               |
| Each part   | Check / Clean       |                  |                  |        |              |               |
| Engine oil  | Check / Replenish   |                  |                  |        |              |               |
|   | Change              |                  |                  |        |              |               |
| Oil filter cartridge  | Change              |                  |                  |        |              |               |
| Spark plug  | Clean               |                  |                  |        |              |               |
|   | Adjust              |                  |                  |        |              |               |
|   | Change              |                  | ●                |        |              |               |
| Air cleaner element   | Check               |                  |                  |        |              |               |
|   | Clean               |                  |                  |        |              |               |
|   | Change              |                  |                  | ●*1    |              |               |
| Intake pipe / clamp bands   | Change              |                  |                  |        | ●            |               |
| Fuel filter   | Check               |                  |                  |        |              |               |
|   | Change              |                  |                  | ●      |              |               |
| Fuel tank   | Clean               |                  |                  | ●      |              | Gasoline line |
|   | Check setting       |                  |                  |        |              | LPG line      |
| Fuel pipe / clamps (Gasoline line)                                | Check               |                  |                  |        |              |               |
|   | Change              |                  |                  | ●      |              |               |
| Fuel pipe / clamps (LPG line: LPG tank to regulator assy (D-EPR)) | Check the connector |                  |                  |        |              |               |
|   | Check fuel leakage  |                  |                  |        |              |               |
|   | Change              |                  |                  |        | ●            |               |

▲ : If necessary

**IMPORTANT:**

\*1 Change more often when operating under dusty conditions.

\*2 If you do not have the proper tools and/or are not mechanically proficient, contact your local KUBOTA dealer.

To ensure the best quality and reliability, use new KUBOTA Genuine parts or their equivalents for repair and replacement, whenever you have maintenance done.

770085





# Engine Maintenance: Kubota

| Items                          |                     | Interval              |                         |                 |                 | Remarks        |
|--------------------------------|---------------------|-----------------------|-------------------------|-----------------|-----------------|----------------|
|                                |                     | Every 8 hours (daily) | Every 50 hours (weekly) | Every 100 hours | Every 200 hours |                |
| Breather tube                  | Change              |                       |                         |                 |                 |                |
| PCV valve                      | Check               |                       |                         |                 |                 |                |
| LPG vaporizer regulator        | Check               |                       |                         |                 |                 | Hot water line |
|                                | Change              |                       |                         |                 |                 | Hot water line |
|                                | Check inner parts*2 |                       |                         |                 |                 |                |
| LPG Lock off valve             | Check               |                       |                         |                 |                 |                |
| Battery                        | Check               |                       |                         | ●               |                 |                |
|                                | Change              |                       |                         |                 |                 |                |
| Radiator coolant               | Check               | ●                     |                         |                 |                 |                |
|                                | Change              |                       |                         |                 |                 |                |
| Radiator hoses and clamp bands | Check               |                       |                         |                 | ●               |                |
|                                | Change              |                       |                         |                 |                 |                |
| Radiator and water jacket      | Clean               |                       |                         |                 |                 |                |
| Fan belt tension               | Check               |                       |                         | ●               |                 |                |
|                                | Adjust              |                       |                         | ▲               |                 |                |
| Valve clearance                | Adjust              |                       |                         |                 |                 |                |

▲: If necessary

**IMPORTANT:**

\*1 Change more often when operating under dusty conditions.

\*2 If you do not have the proper tools and/or are not mechanically proficient, contact your local KUBOTA dealer.

To ensure the best quality and reliability, use new KUBOTA Genuine parts or their equivalents for repair and replacement, whenever you have maintenance done.

770086

# Engine Maintenance: Kubota

| Items                          |                     | Interval         |                  |        |              | Remarks        |
|--------------------------------|---------------------|------------------|------------------|--------|--------------|----------------|
|                                |                     | Every 1000 hours | Every 2000 hours | Yearly | Each 2 years |                |
| Breather tube                  | Change              |                  |                  |        | ●            |                |
| PCV valve                      | Check               | ●                |                  |        |              |                |
| LPG vaporizer regulator        | Check               | ●                |                  |        |              | Hot water line |
|                                | Change              |                  |                  |        | ●            | Hot water line |
|                                | Check inner parts*2 |                  |                  |        | ●            |                |
| LPG Lock off valve             | Check               | ●                |                  |        |              |                |
| Battery                        | Check               |                  |                  |        |              |                |
|                                | Change              |                  |                  |        | ●            |                |
| Radiator coolant               | Check               |                  |                  |        |              |                |
|                                | Change              |                  |                  |        | ●            |                |
| Radiator hoses and clamp bands | Check               |                  |                  |        |              |                |
|                                | Change              |                  |                  |        | ●            |                |
| Radiator and water jacket      | Clean               |                  |                  | ●      |              |                |
| Fan belt tension               | Check               |                  |                  |        |              |                |
|                                | Adjust              |                  |                  |        |              |                |
| Valve clearance                | Adjust              | ●*2              |                  |        |              |                |

▲: If necessary

**IMPORTANT:**

\*1 Change more often when operating under dusty conditions.

\*2 If you do not have the proper tools and/or are not mechanically proficient, contact your local KUBOTA dealer.

To ensure the best quality and reliability, use new KUBOTA Genuine parts or their equivalents for repair and replacement, whenever you have maintenance done.

770087



9 Troubleshooting

| Problem  | Cause  | Remedy  |
|--|--|---|
| Engine doesn't start                                     | No fuel in tank  | Add fuel.   |
|  | Battery connections loose or corroded                                    | Check and clean battery connections.                                      |
|  | Battery charge low   | Charge or replace battery.  |
|  | Defective starter  | Replace starter.  |
| Engine is hard to start.                                 | No fuel in tank  | Add fuel.<br>Bleed fuel lines.  |
|  | Battery charge low   | Charge or replace battery.  |
|  | Fuel filter clogged  | Replace fuel filter.  |
|  | Fuel circuit failure   | Check fuel lines.   |
| Machine out of balance; wobbling excessively             | Trowel arm(s) bent   | Replace trowel arm(s).  |
|  | Trowel arm(s) out of adjustment  | Adjust trowel arm(s).   |
|  | Trowel blade(s) bent   | Replace trowel blade(s).  |
| Poor handling; excessive free play in steering mechanism | Worn pivot bearings, rod ends, and/or cylinder mounts                    | Inspect pivot bearings, rod ends, and cylinder mounts. Replace as needed. |
| Machine does not move                                    | Drive belt broken  | Replace drive belt.   |
|  | A vacuum exists between bottom of blades or pans and surface of concrete | Change pitch on blades or actuate steering system to break suction.       |
|  | Key sheared in the gearbox output shaft                                  | Replace damaged key.  |

## 9.1 Setting Up the Diagnostic Tool

**Background** A diagnostic tool is available to aid in diagnosing component malfunctions. The diagnostic tool consists of an application program provided by Danfoss, a series of diagnostic files depending on the machine model, and a cable assembly to connect the machine to a computer.

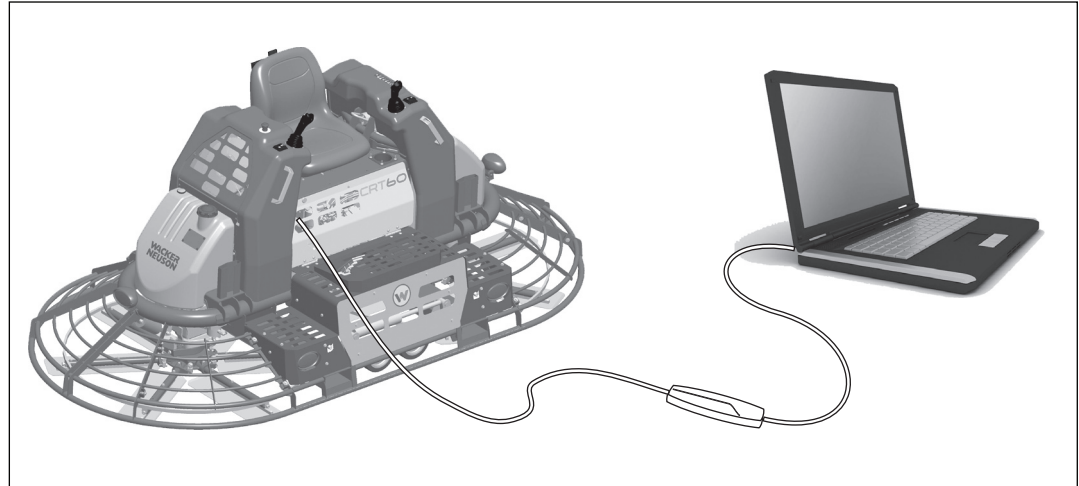

wc\_gr012302

**Download the software** Perform the procedure below to download the software.

1. Navigate to the following internet address:  
<http://powersolutions.danfoss.com/products/PLUS-1-GUIDE/PLUS-1-software-download-and-license/>
2. Download the file “PLUS+1 GUIDE Service Tool (free Service Tool only) versions 7.1.12 (.zip 51 MB)”.

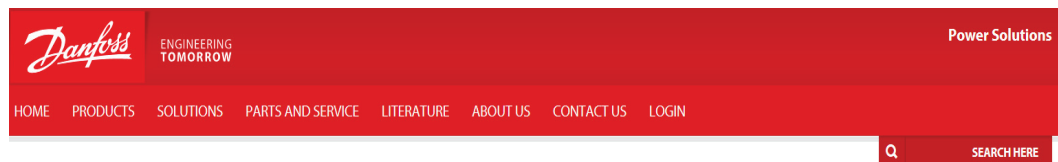

### PLUS+1® software download and license

The applications that are created using and adjusted by PLUS+1 Tools typically control heavy, powerful, mobile off-road machinery such as tractors, cranes, and harvesters.

You should read the risk reduction section of the PLUS+1 manuals.

By downloading the software you agree to:

1. Receive communications from Danfoss to inform you of changes or notification about the PLUS+1 Tools.
2. The PLUS+1 Service Tool can be redistributed by you. In the event that you redistribute the software, then you undertake to; i pass on any communication from Danfoss regarding the safe operation of the tool, if place the same obligations on anyone else that redistributes the tool.

If you require help, please send an email describing the support needed to:

- PLUS+1helpdesk@Danfoss.com

Or for phone support in:

- North America call our toll free number +1-888-50PLUS1 (1-888-507-5871)
- Europe call +46 476-569 06.

You can also visit our PLUS+1 Forum: [www.plus1forum.danfoss.com](http://www.plus1forum.danfoss.com)

#### Download

PLUS+1® GUIDE software and supporting documents.

> PLUS+1® GUIDE 7.1.12 setup (.zip 337 MB)

> PLUS+1® GUIDE Software Readme (PDF 0.2 MB)

> PLUS+1® GUIDE Service Tool (free Service Tool only) version 7.1.12 (.zip 51 MB)

> PLUS+1® GUIDE Service Tool Software Readme (PDF 0.2 MB)

**Download the diagnostic file**

The trowel diagnostic files are available as attachments to the PDF version of the Operator's Manual and/or the Repair Manual for your machine. See the Wacker Neuson Web site: [www.wackerneuson.com](http://www.wackerneuson.com).

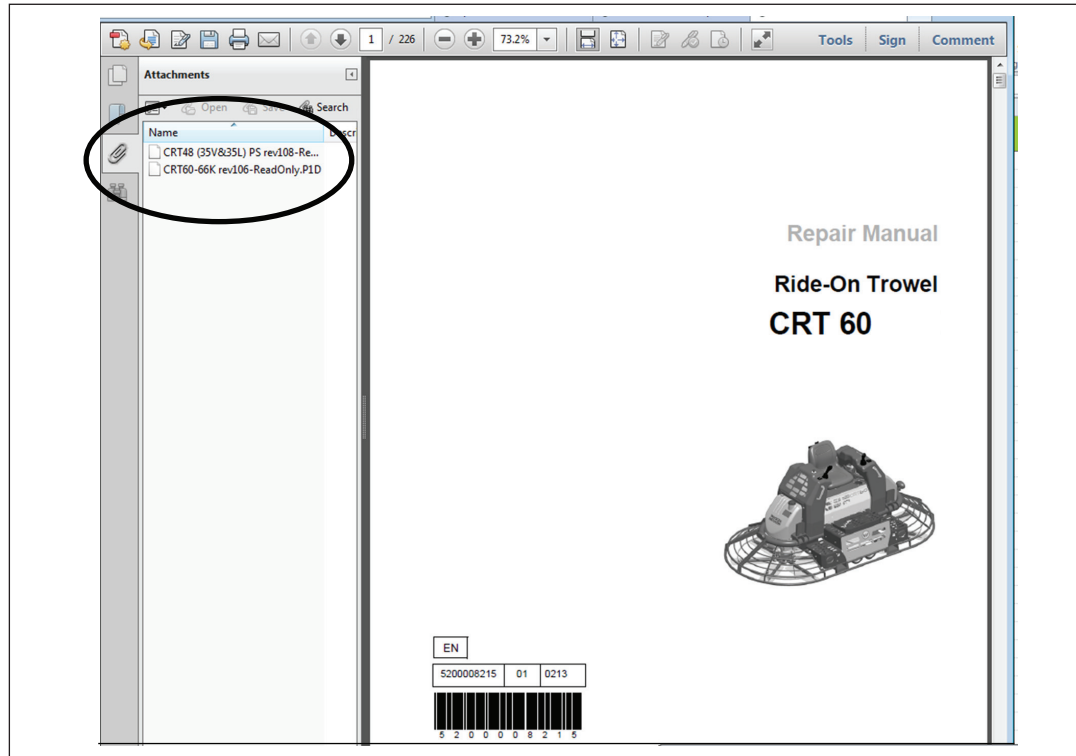

wc\_gr012306

**Connections** Perform the procedure below to connect the computer to the machine.

1. Plug the USB cable into the computer to be used for diagnostics. The green “PWR” LED will illuminate when connected properly.

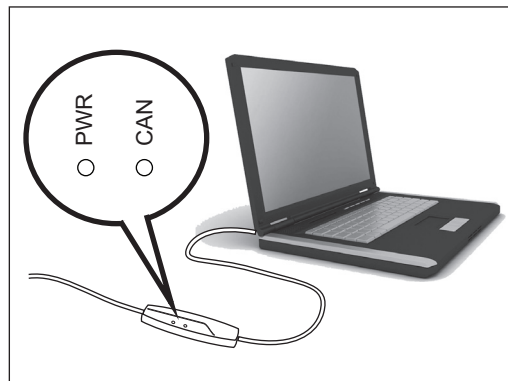

wc\_gr012305

2. Locate the trowel's 3-pin connector (**x**).

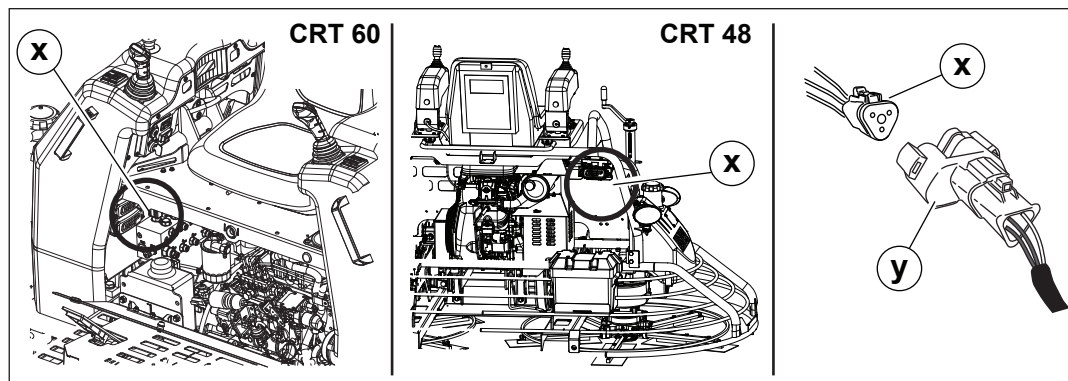

wc\_gr012304

3. Connect the cable (**y**) to the trowel's 3-pin connector.

**Starting the Program**

1. Turn the key to the ON position, or start the engine.
2. Start the PLUS+1 GUIDE Service Tool program.
  - ▶ If prompted, select gateway “CG 150”.
  - ▶ If prompted, select channel CG150 #0 (Channel 0).
3. Confirm the proper channel selection.
  - a. Click the “Communication” tab.
  - b. Click “Gateway”.
  - c. Click “CG150”.
  - d. Click “Sauer-Danfoss CG150 #0 (Channel 0)”.

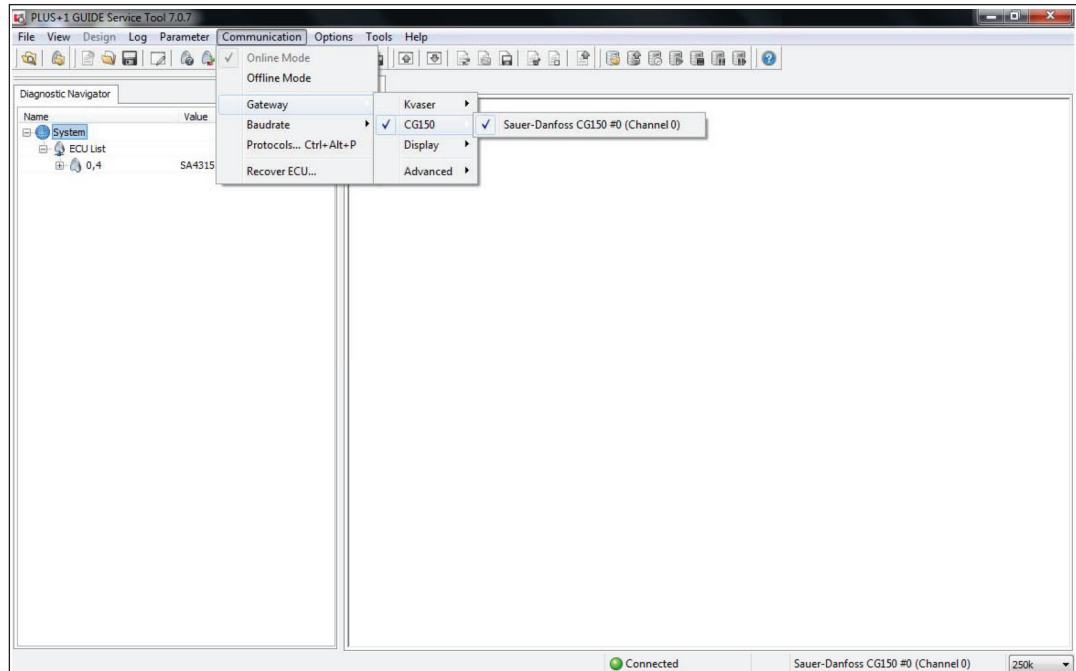

wc\_gr012307

*This procedure continues on the next page.*

Continued from the previous page.

4. Open the appropriate diagnostic file for the machine you are working on.

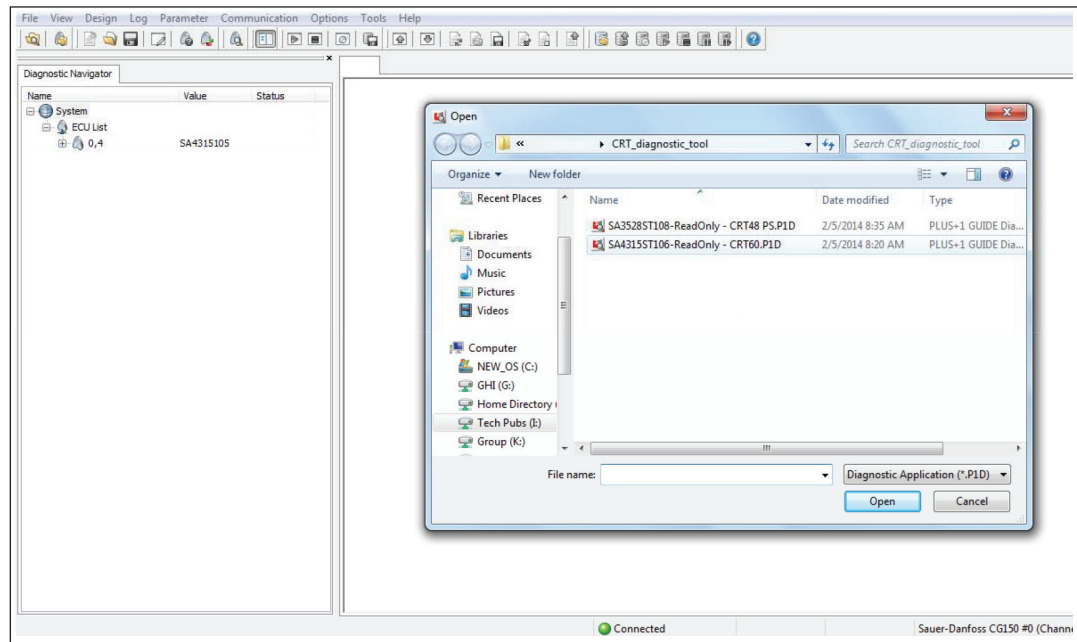

wc\_gr012308

5. After the file loads, click "Main".

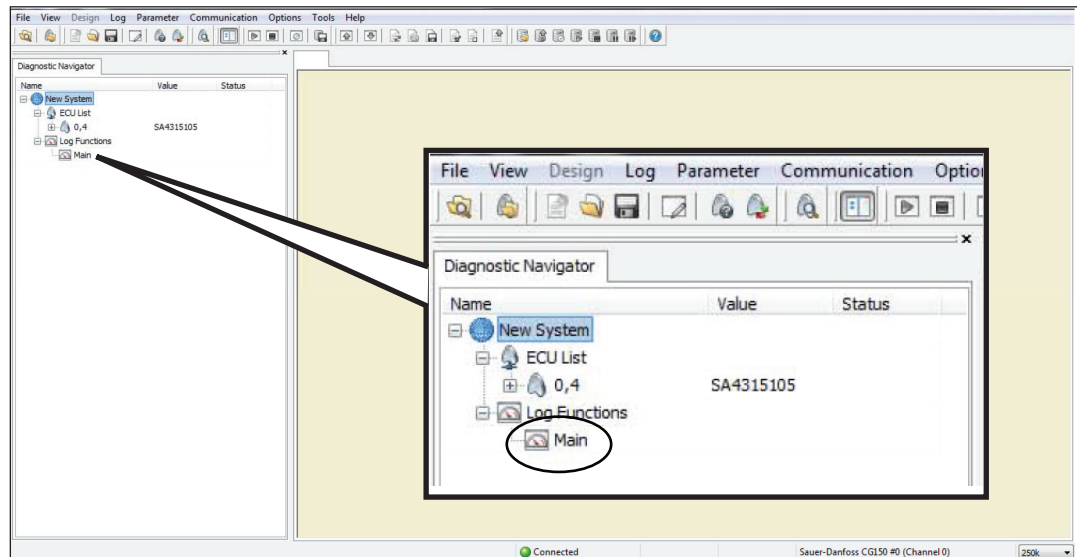

wc\_gr012309

This procedure continues on the next page.



Continued from the previous page.

- The diagnostic screen appears. The diagnostic screen shows the voltage and amperage values that are being sent to the controller via the joysticks and via the foot pedal. It also shows the amperage values being sent from the controller to the valves on the manifold.

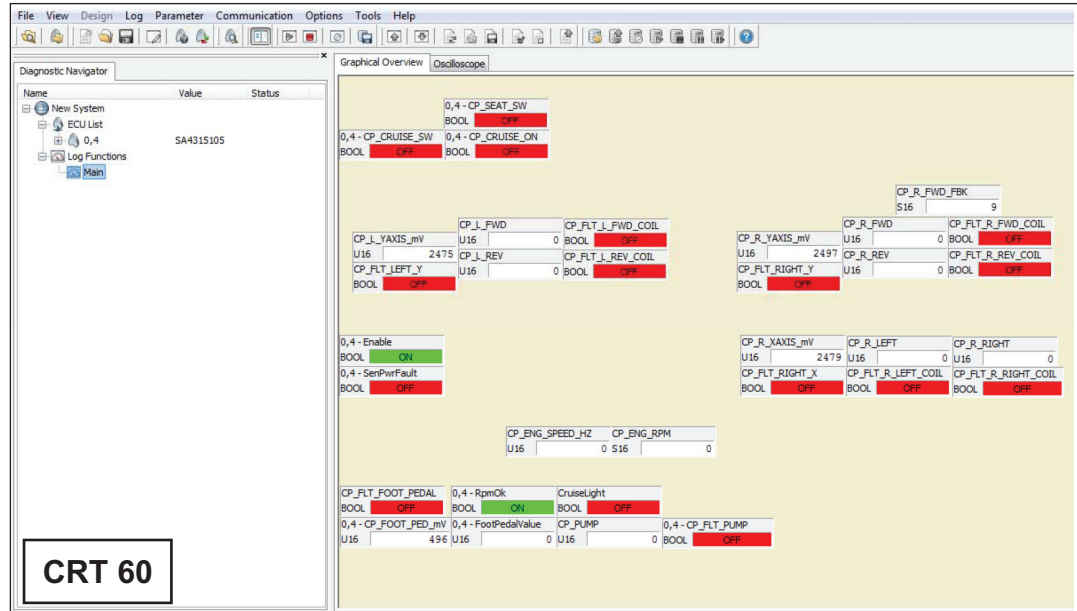

wc\_gr012310

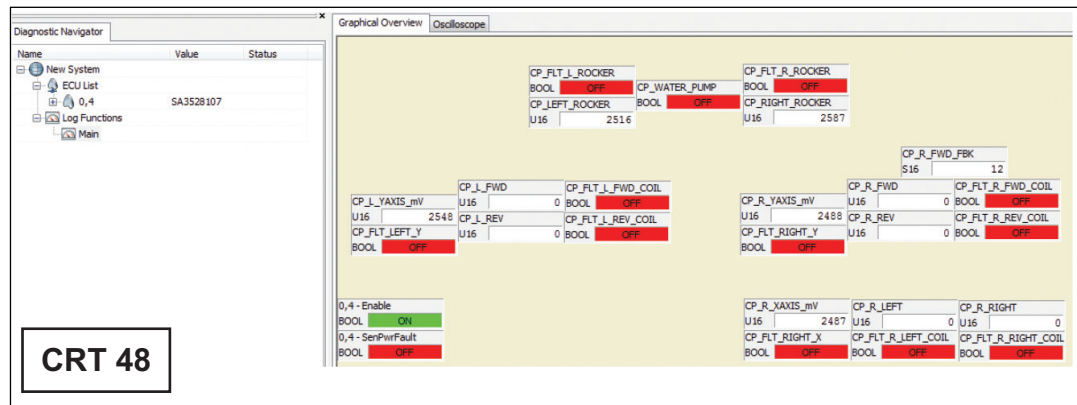

wc\_gr012311

This procedure continues on the next page.

Continued from the previous page.

## CRT 60 Readout explanations

CRT 60 diagnostic screen is shown below.

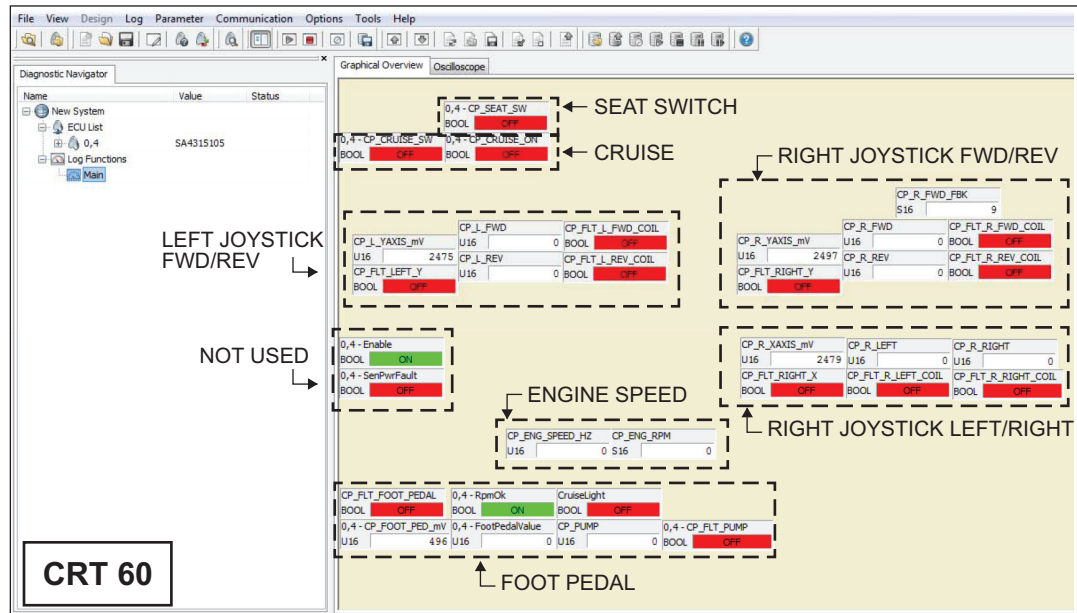

wc\_gr012312

### Seat switch

| Identifier       | Meaning                                |
|------------------|--|
| 0,4 - CP_SEAT_SW | Switch position: green = ON; red = OFF |

### Cruise

|                    |   |
|--------------------|---|
| 0,4 - CP_CRUISE_SW | Switch position: green = ON; red = OFF        |
| 0,4 - CP_CRUISE_ON | Running in cruise mode: green = ON; red = OFF |

### Left joystick FWD/REV

|                   |   |
|-------------------|---|
| CP_L_Y_AXIS_mV    | Voltage (mV) from left joystick to controller:<br>500 = REV, 2500 = Neutral, 4500 = FWD |
| CP_FLT_LEFT_Y     | Left joystick fault: red = no fault; green = fault                                      |
| CP_L_FWD          | Amperage from controller to valve (2B) 16000 = 1.6A                                     |
| CP_L_REV          | Amperage from controller to valve (2A) 16000 = 1.6A                                     |
| CP_FLT_L_FWD_COIL | Power to valve (2B): green = yes; red = no  |
| CP_FLT_L_REV_COIL | Power to valve (2A): green = yes; red = no  |

### Right joystick FWD/REV

|                |  |
|----------------|--|
| CP_R_Y_AXIS_mV | Voltage (mV) from right joystick to controller:<br>500 = REV, 2500 = Neutral, 4500 = FWD |
| CP_FLT_LEFT_Y  | Left joystick fault: red = no fault; green = fault                                       |
| CP_R_FWD       | Amperage from controller to valve (1B) 16000 = 1.6A                                      |
| CP_R_REV       | Amperage from controller to valve (1A) 16000 = 1.6A                                      |

|                   |  |
|-------------------|--|
| CP_R_YAXIS_mV     | Voltage (mV) from right joystick to controller:<br>500 = REV, 2500 = Neutral, 4500 = FWD |
| CP_FLT_LEFT_Y     | Left joystick fault: red = no fault; green = fault                                       |
| CP_FLT_R_FWD_COIL | FWD valve (1B) fault: red = no fault; green = fault                                      |
| CP_FLT_R_REV_COIL | REV valve (1A) fault: red = no fault; green = fault                                      |
| CP_R_FWD_FBK      | Not used   |

**Right joystick  
LEFT/RIGHT**

|                     |  |
|---------------------|--|
| CP_R_XAXIS_mV       | Voltage (mV) from right joystick to controller:<br>500 = REV, 2500 = Neutral, 4500 = FWD |
| CP_FLT_RIGHT_X      | Right joystick fault: red = no fault; green = fault                                      |
| CP_R_LEFT           | Amperage from controller to valve (3B) 16000 = 1.6A                                      |
| CP_R_RIGHT          | Amperage from controller to valve (3A) 16000 = 1.6A                                      |
| CP_FLT_R_LEFT_COIL  | Left direction valve (3B) fault: red = no fault; green = fault                           |
| CP_FLT_R_RIGHT_COIL | Right direction valve (3A) fault: red = no fault; green = fault                          |

**Engine speed**

|                 |                       |
|-----------------|-----------------------|
| CP_ENG_SPEED_Hz | Engine speed in Hertz |
| CP_ENG_RPM      | Engine speed in rpm   |

**Foot pedal**

|                      |   |
|----------------------|---|
| CP_FLT_FOOT_PEDAL    | Foot pedal fault: red = no fault; green = fault                                       |
| 0,4 - CP_FOOT_PED_mV | Voltage (mV) from right foot pedal to controller:<br>500 no movement; 4500 full speed |
| 0,4 - RpmOk          |   |
| 0,4 - FootPedalValue |   |
| CruiseLight          | Cruise light: green = ON; red = OFF   |
| CP_PUMP              |   |
| 0,4 - CP_FLT_PUMP    | Pump fault: red = no fault; green = fault   |

*This procedure continues on the next page.*

Continued from the previous page.

## CRT 48 Readout explanations

CRT 48 diagnostic screen is shown below.

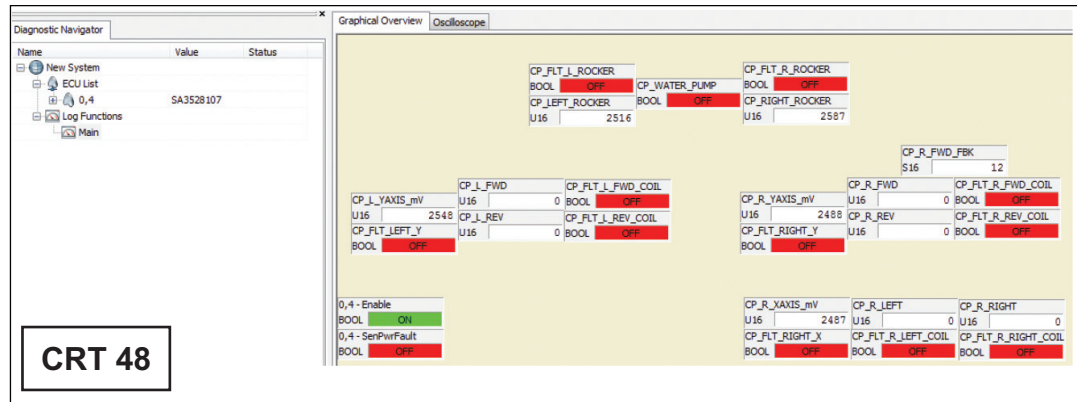

wc\_gr012311

## Spray system

| Identifier      | Meaning  |
|-----------------|--|
| CP_FLT_L_ROCKER | Left rocker switch fault: red = no fault; green = fault  |
| CP_LEFT_ROCKER  |  |
| CP_WATER_PUMP   | Red = OFF; green = ON                                    |
| CP_FLT_R_ROCKER | Right rocker switch fault: red = no fault; green = fault |
| CP_RIGHT_ROCKER |  |

## Left joystick FWD/REV

|                   |   |
|-------------------|---|
| CP_L_Y_AXIS_mV    | Voltage (mV) from left joystick to controller:<br>500 = REV, 2500 = Neutral, 4500 = FWD |
| CP_FLT_LEFT_Y     | Left joystick fault: red = no fault; green = fault                                      |
| CP_L_FWD          | Amperage from controller to valve (2B) 16000 = 1.6A                                     |
| CP_L_REV          | Amperage from controller to valve (2A) 16000 = 1.6A                                     |
| CP_FLT_L_FWD_COIL | Power to valve (2B): green = yes; red = no  |
| CP_FLT_L_REV_COIL | Power to valve (2A): green = yes; red = no  |

## Right joystick FWD/REV

|                   |  |
|-------------------|--|
| CP_R_Y_AXIS_mV    | Voltage (mV) from right joystick to controller:<br>500 = REV, 2500 = Neutral, 4500 = FWD |
| CP_FLT_LEFT_Y     | Left joystick fault: red = no fault; green = fault                                       |
| CP_R_FWD          | Amperage from controller to valve (1B) 16000 = 1.6A                                      |
| CP_R_REV          | Amperage from controller to valve (1A) 16000 = 1.6A                                      |
| CP_FLT_R_FWD_COIL | FWD valve (1B) fault: red = no fault; green = fault                                      |
| CP_FLT_R_REV_COIL | REV valve (1A) fault: red = no fault; green = fault                                      |
| CP_R_FWD_FBK      | Not used   |

**Right joystick  
LEFT/RIGHT**

|                     |  |
|---------------------|--|
| CP_R_XAXIS_mV       | Voltage (mV) from right joystick to controller:<br>500 = REV, 2500 = Neutral, 4500 = FWD |
| CP_FLT_RIGHT_X      | Right joystick fault: red = no fault; green = fault                                      |
| CP_R_LEFT           | Amperage from controller to valve (3B) 16000 = 1.6A                                      |
| CP_R_RIGHT          | Amperage from controller to valve (3A) 16000 = 1.6A                                      |
| CP_FLT_R_LEFT_COIL  | Left direction valve (3B) fault: red = no fault; green = fault                           |
| CP_FLT_R_RIGHT_COIL | Right direction valve (3A) fault: red = no fault; green = fault                          |

**10 Technical Data**

**10.1 Engine**

| Model                                |                                     | CRT48-35L-PS                          | CRT 48-37V-PS                         | CRT 48-57K-PS                        |
|--------------------------------------|-------------------------------------|---------------------------------------|---------------------------------------|--------------------------------------|
| Engine make                          |                                     | Kohler                                | Vanguard                              | Kubota                               |
| Engine model                         |                                     | KDW1404                               | A/C V-Twin                            | WG1605-G                             |
| Maximum rated power @<br>rated speed | kW (hp)                             | 26 (34.9) @ 3,600<br>rpm <sup>2</sup> | 27.6 (37) @ 3,600<br>rpm <sup>1</sup> | 42.5 (57) @ 3600<br>rpm <sup>1</sup> |
| Displacement                         | cm <sup>3</sup> (in. <sup>3</sup> ) | 1,372 (84)                            | 993 (61)                              | 1,537 (93.8)                         |
| Operating speed                      | rpm                                 | 3,600                                 | 4,000                                 | 3,600                                |
| Engine speed—idle                    |                                     | 1,450                                 | 1,200                                 | 1,000                                |
| Battery                              | V / size                            | 12 / BCI G 24                         |                                       |                                      |
| Fuel type                            | type                                | Clean, filtered #1 or<br>#2 diesel    | Regular unleaded gasoline             |                                      |
| Fuel tank capacity                   | L (gal)                             | 24.6 (6.5)                            |                                       |                                      |
| Fuel consumption                     | L (gal)/hr                          | 6.2 (1.7)                             | 10 (2.75)                             | 9.5 (2.5)                            |
| Running time                         | hr                                  | 4.0                                   | 2.5                                   | 2.6                                  |
| Clutch                               | type                                | Variable speed                        |                                       |                                      |
| Engine oil capacity                  | L (qt)                              | 5.2 (5.4)                             | 2.3 (2.4)                             | 6.0 (6.3)                            |
| Engine lubrication                   | oil grade                           | 10W40                                 | 10W30                                 |                                      |

<sup>1</sup>Gross power rating per SAE J1995. Actual power output may vary due to conditions of specific use.

<sup>2</sup>Net power rating per ISO 1585. Actual power output may vary due to conditions of specific use.

**10.2 Trowel**

| Machine                |                | CRT48-35L-PS                          | CRT 48-37V-PS | CRT 48-57K-PS |
|------------------------|----------------|---------------------------------------|---------------|---------------|
| Operating weight       | kg (lb)        | 643 (1420)                            | 600 (1324)    | 660 (1456)    |
| Dimensions (L x W x H) | mm (in.)       | 2566 x 1295 x 1473<br>(101 x 51 x 58) |               |               |
| Rotor speed (range)    | rpm            | 25–150                                | 25–165        | 25–150        |
| Blade pitch (range)    | degrees        | 0–25                                  |               |               |
| Gearbox                | type           | Heavy duty, fan cooled                |               |               |
| Gearbox lubrication    | type           | Mobil Glygoyle 460                    |               |               |
|                        | L (oz.)        | 1.83 (62) each                        |               |               |
| Driveshaft             | type           | Splined universal joint               |               |               |
| Hydraulic reservoir    | type<br>L (qt) | 10W30 hydraulic fluid<br>12 (13)      |               |               |

| Operation  |                                   |  |
|--|-----------------------------------|--|
| Troweling width<br><b>with pans</b><br>(non-overlapping) | mm (in.)                          | 2465 (97)                                |
|  |                                   | <b>without pans</b><br>(non-overlapping) |
| Troweling area<br><b>with pans</b><br>(non-overlapping)  | m <sup>2</sup> (ft <sup>2</sup> ) | 3 (32)                                   |
|  |                                   | <b>without pans</b><br>(non-overlapping) |

### 10.3 Sound Measurements

Products are tested for sound pressure level in accordance with ISO 3744 for the sound power level ( $L_{WA}$ ) and ISO 11204 for the sound pressure level ( $L_{PA}$ ) at the operator's location. The required sound specifications, per Annex VIII, European Directive 2006/42/EC of the EC Machine Regulations, are:

| Machine       | Sound Pressure at Operator's Location dB(A) | Guaranteed Sound Power dB(A) |
|---------------|---|------------------------------|
| CRT 48-35L-PS | 91.1  | 110.2                        |
| CRT 48-37V-PS | 94.8  | 110.3                        |
| CRT 48-57K-PS | 94.3  | 111.7                        |

### 10.4 Vibration Measurements

Products are tested for hand/arm vibration (HAV) level and whole body vibration in accordance with ISO 5349, EN 1033, and ISO 2631 where applicable.

| Machine       | HAV m/sec <sup>2</sup> | Whole body m/sec <sup>2</sup> |
|---------------|------------------------|-------------------------------|
| CRT 48-35L-PS | 2.14                   | 0.9                           |
| CRT 48-37V-PS | 2.20                   | 0.5                           |
| CRT 48-57K-PS | 3.00                   | 0.4                           |

#### Vibration uncertainties

Hand-transmitted vibration was measured per ISO 5349-1. This measurement includes an uncertainty of 1.5 m/s<sup>2</sup>.

Whole body vibration was measured per ISO 2631-1. This measurement includes an uncertainty of 0.3 m/s<sup>2</sup>.



10.5 Dimensions

mm (in.)

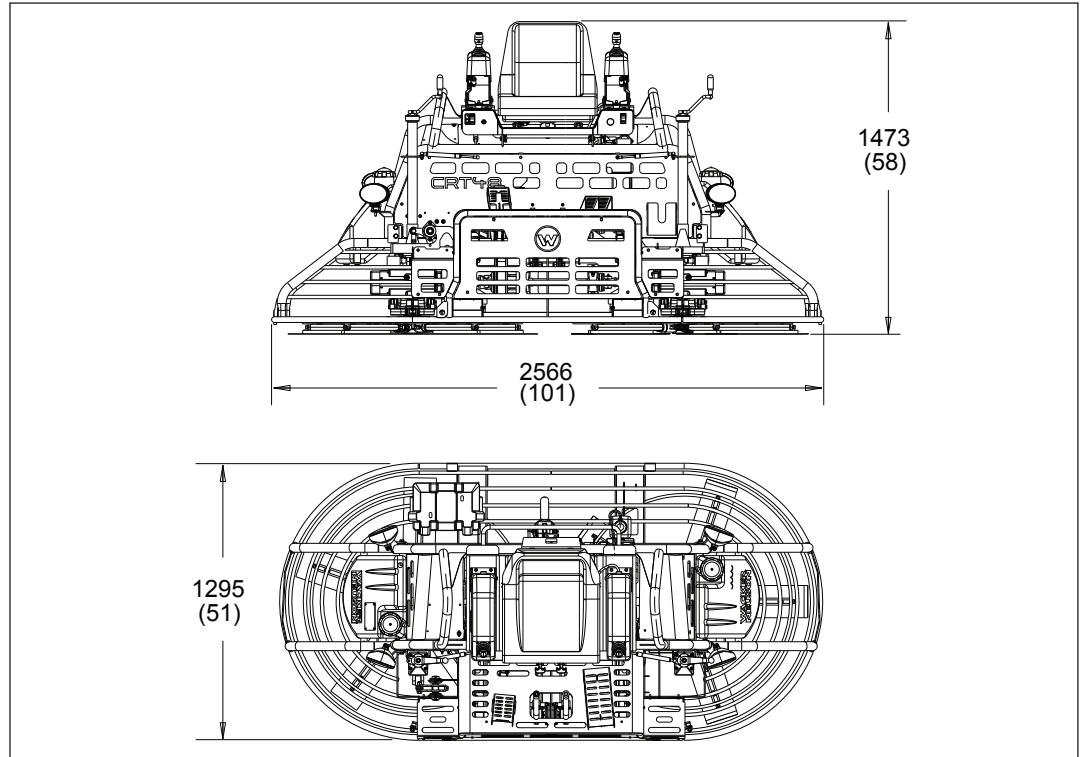

wc\_gr011881

Notes

## 11 Emission Control Systems Information and Warranty—Diesel

The Emission Control Warranty and associated information is valid only for the U.S.A., its territories, and Canada.

### 11.1 Emission Control System Background Information

#### Introduction

Wacker Neuson engines/equipment must conform with applicable Environmental Protection Agency (EPA) and California Air Resource Board (CARB) emissions regulations. These regulations require that manufacturers warrant the emission control systems for defects in materials and workmanship.

Furthermore, EPA and CARB regulations require all manufacturers to furnish written instructions describing how to operate and maintain the engines/equipment including the emission control systems. This information is provided with all Wacker Neuson engines/equipment at the time of purchase.

---

#### Exhaust Emissions

The combustion process produces carbon monoxide, oxides of nitrogen, and hydrocarbons. Control of hydrocarbons and oxides of nitrogen is very important because, under certain conditions, they react to form photochemical smog when subjected to sunlight. Carbon monoxide does not react in the same way, but it is toxic.

---

#### Problems that may affect Emissions

If any of the following symptoms arise, have the engine/equipment inspected and repaired by a Wacker Neuson dealer/service center.

- Hard starting or stalling after starting
  - Rough idling
  - Misfiring or backfiring under load
  - Afterburning (backfiring)
  - Presence of black exhaust smoke during operation
  - High fuel consumption
- 

#### Tampering and Altering

Tampering with or altering the emission control system may increase emissions beyond the legal limit. If evidence of tampering is found, Wacker Neuson may deny a warranty claim. Among those acts that constitute tampering are:

- Removing or altering of any part of the air intake, fuel, or exhaust systems.
- Altering or defeating the speed-adjusting mechanism causing the engine to operate outside its design parameters.

### 11.2 Limited Defect Warranty for Wacker Neuson Emission Control Systems

The Emission Control Warranty is valid only for the U.S.A., its territories, and Canada.

Wacker Neuson Sales Americas, LLC, N92 W15000 Anthony Avenue, Menomonee Falls, WI 53051, (hereinafter “Wacker Neuson”) warrants to the initial retail purchaser and each subsequent owner, that this engine/equipment, including all parts of its emission control system, have been designed, built, and equipped to conform at the time of initial sale to all applicable evaporative emission regulations of the U.S. Environmental Protection Agency (EPA), and that the engine/equipment is free of defects in materials and workmanship which would cause this engine/equipment to fail to conform to EPA regulations during its warranty period.

Wacker Neuson is also liable for damages to other engine/equipment components caused by a failure of any warranted parts during the warranty period.

---

#### What is covered

Wacker Neuson recommends the use of genuine Wacker Neuson parts, or the equivalent, whenever maintenance is performed. The use of replacement parts not equivalent to the original parts may impair the effectiveness of the engine/equipment emission controls systems. If such a replacement part is used in the repair or maintenance of the engine/equipment, assure yourself that such part is warranted by its manufacturer to be equivalent to the parts offered by Wacker Neuson in performance and durability. Furthermore, if such a replacement part is used in the repair or maintenance of the engine/equipment, and an authorized Wacker Neuson dealer/service center determines it is defective or causes a failure of a warranted part, the claim for repair of the engine/equipment may be denied. If the part in question is not related to the reason the engine/equipment requires repair, the claim will not be denied.

For the components listed in the following table, an authorized Wacker Neuson dealer/service center will, at no cost to you, make the necessary diagnosis, repair, or replacement necessary to ensure that the engine/equipment complies with the applicable EPA regulations. All defective parts replaced under this warranty become property of Wacker Neuson.

#### What is not covered

- Failures other than those resulting from defects in material or workmanship.
- Any systems or parts which are affected or damaged by owner abuse, tampering, neglect, improper maintenance, misuse, improper fueling, improper storage, accident and/or collision; the incorporation of, or any use of, add-on or modified parts, or unsuitable attachments, or the alteration of any part.
- Replacement of expendable maintenance items made in connection with required maintenance services after the item’s first scheduled replacement as listed in the maintenance section of the engine/equipment operator’s manual, such as spark plugs and filters.



## Emission Control Systems Information and Warranty—Diesel

- Incidental or consequential damages such as loss of time or the use of the engine/equipment, or any commercial loss due to the failure of the engine/equipment.
  - Diagnosis and inspection charges that do not result in warranty-eligible service being performed.
  - Any non-authorized replacement part, or malfunction of authorized parts due to use of non-authorized parts.
- 

### Owner's Warranty Responsibility

The engine/equipment owner, is responsible for the performance of the required maintenance listed in the Wacker Neuson engine/equipment operator's manual. Wacker Neuson recommends that all receipts covering maintenance on the engine/equipment be retained, but Wacker Neuson cannot deny warranty coverage solely for the lack of receipts or for the failure to ensure the performance of all scheduled maintenance.

Normal maintenance, replacement, or repair of emission control devices and systems may be performed by any repair establishment or individual; however, warranty repairs must be performed by an authorized Wacker Neuson dealer/service center.

The engine/equipment must be presented to an authorized Wacker Neuson dealer/service center as soon as a problem exists. Contact Wacker Neuson Product Support Department (1-800-770-0957) or visit [wackerneuson.com](http://wackerneuson.com) to find a dealer/service center in your area, or to answer questions regarding warranty rights and responsibilities.



### How to Make a Claim

In the event that any emission-related part is found to be defective during the warranty period, you shall notify Wacker Neuson Product Support Department (1-800-770-0957, or [technical.support@wackerneuson.com](mailto:technical.support@wackerneuson.com), or [wackerneuson.com](http://wackerneuson.com)), and you will be advised of the appropriate dealer/service center where warranty repair can be performed. All repairs qualifying under this limited warranty must be performed by an authorized Wacker Neuson dealer/service center.

You must take your Wacker Neuson engine/equipment along with proof of original purchase date, at your expense, to the authorized Wacker Neuson dealer/service center during their normal business hours.

For owners located more than 100 miles from an authorized dealer/service center (excluding the states with high-altitude areas as identified in 40 CFR Part 1068, Appendix III), Wacker Neuson will pay for pre-approved shipping costs to and from an authorized Wacker Neuson dealer/service center.

Claims for repair or adjustment found to be caused solely by defects in material or workmanship will not be denied because the engine/equipment was not properly maintained and used.

The warranty repairs should be completed in a reasonable amount of time, not to exceed 30 days.



# Emissions Control Systems Information and Warranty

## 11 Emissions Control Systems Information and Warranty

| System Covered  | Components   |
|---|--|
| Air filter system and associated plumbing<br>(Before engine intake) | Air filter   |
| Exhaust system  | Exhaust system connected after the<br>exhaust manifold |

## 11 Emissions Control Systems Information and Warranty

### Limited Defect Warranty Period for Wacker Neuson Emission Control Systems

The warranty period for this engine/equipment begins on the date of sale to the initial purchaser and continues for a period of 5 years or 3000 hours of operation (whichever comes first). For the warranty terms for your specific engine/equipment, visit [wackerneuson.com](http://wackerneuson.com).

Any implied warranties are limited to the duration of this written warranty.





## 12 Emission Control Systems Information and Warranty—Gasoline

The Emission Control Warranty and associated information is valid only for the U.S.A., its territories, and Canada.

### 12.1 Emission Control System Background Information

#### Introduction

Wacker Neuson spark-ignited engines/equipment must conform with applicable Environmental Protection Agency (EPA) emissions regulations. There are two types of emissions that fall under these regulations: 1) exhaust, and 2) evaporative. These regulations require that manufacturers warrant the emission control systems for defects in materials and workmanship.

Furthermore, EPA regulations require all manufacturers to furnish written instructions describing how to operate and maintain the engines/equipment including the emission control systems. This information is provided with all Wacker Neuson engines/equipment at the time of purchase.

---

#### Exhaust Emissions

The combustion process produces carbon monoxide, oxides of nitrogen, and hydrocarbons. Control of hydrocarbons and oxides of nitrogen is very important because, under certain conditions, they react to form photochemical smog when subjected to sunlight. Carbon monoxide does not react in the same way, but it is toxic.

Wacker Neuson utilizes lean carburetor settings and other systems to reduce the emissions of carbon monoxide, oxides of nitrogen, and hydrocarbons.

---

#### Evaporative Emissions

Evaporative emissions are fuel emissions and generally include emissions that result from permeation of fuel through the fuel-system materials or from ventilation of the fuel system.

Wacker Neuson utilizes low-permeation fuel lines and fuel tanks where applicable to reduce evaporative emissions.

---

#### Problems that may affect Emissions

If any of the following symptoms arise, have the engine/equipment inspected and repaired by a Wacker Neuson dealer/service center.

- Hard starting or stalling after starting
- Rough idling
- Misfiring or backfiring under load
- Afterburning (backfiring)
- Presence of black exhaust smoke during operation
- High fuel consumption

## Tampering and Altering

Tampering with or altering the emission control system may increase emissions beyond the legal limit. If evidence of tampering is found, Wacker Neuson may deny a warranty claim. Among those acts that constitute tampering are:

- Removing or altering of any part of the air intake, fuel, or exhaust systems.
- Altering or defeating the speed-adjusting mechanism causing the engine to operate outside its design parameters.

## 12.2 Limited Defect Warranty for Wacker Neuson Emission Control Systems

The Emission Control Warranty is valid only for the U.S.A., its territories, and Canada.

Wacker Neuson Sales Americas, LLC, N92 W15000 Anthony Avenue, Menomonee Falls, WI 53051, (hereinafter “Wacker Neuson”) warrants to the initial retail purchaser, and each subsequent owner, that this engine/equipment, including all parts of its emission control systems, have been designed, built, and equipped to conform at the time of initial sale to all applicable emission regulations of the U.S. Environmental Protection Agency (EPA), and that the engine/equipment is free of defects in materials and workmanship which would cause this engine/equipment to fail to conform to EPA regulations during its warranty period.

Wacker Neuson is also liable for damages to other engine/equipment components caused by a failure of any warranted parts during the warranty period.

---

### What is covered

Wacker Neuson recommends the use of genuine Wacker Neuson parts, or the equivalent, whenever maintenance is performed. The use of replacement parts not equivalent to the original parts may impair the effectiveness of the engine/equipment emission controls systems. If such a replacement part is used in the repair or maintenance of the engine/equipment, assure yourself that such part is warranted by its manufacturer to be equivalent to the parts offered by Wacker Neuson in performance and durability. Furthermore, if such a replacement part is used in the repair or maintenance of the engine/equipment, and an authorized Wacker Neuson dealer/service center determines it is defective or causes a failure of a warranted part, the claim for repair of the engine/equipment may be denied. If the part in question is not related to the reason the engine/equipment requires repair, the claim will not be denied.

For the components listed in the following table, an authorized Wacker Neuson dealer/service center will, at no cost to you, make the necessary diagnosis, repair, or replacement necessary to ensure that the engine/equipment complies with the applicable EPA regulations. All defective parts replaced under this warranty become property of Wacker Neuson.

---

### What is not covered

- Failures other than those resulting from defects in material or workmanship.

## Emission Control Systems Information and Warranty—Gasoline

- Any systems or parts which are affected or damaged by owner abuse, tampering, neglect, improper maintenance, misuse, improper fueling, improper storage, accident and/or collision; the incorporation of, or any use of, add-on or modified parts, or unsuitable attachments, or the alteration of any part.
  - Replacement of expendable maintenance items made in connection with required maintenance services after the item's first scheduled replacement as listed in the maintenance section of the engine/equipment operator's manual, such as spark plugs and filters.
  - Incidental or consequential damages such as loss of time or the use of the engine/equipment, or any commercial loss due to the failure of the engine/equipment.
  - Diagnosis and inspection charges that do not result in warranty-eligible service being performed.
  - Any non-authorized replacement part, or malfunction of authorized parts due to use of non-authorized parts.
- 

### Owner's Warranty Responsibility

The engine/equipment owner is responsible for the performance of the required maintenance listed in the Wacker Neuson engine/equipment operator's manual. Wacker Neuson recommends that all receipts covering maintenance on the engine/equipment be retained, but Wacker Neuson cannot deny warranty coverage solely for the lack of receipts or for the failure to ensure the performance of all scheduled maintenance.

Normal maintenance, replacement, or repair of emission control devices and systems may be performed by any repair establishment or individual; however, warranty repairs must be performed by an authorized Wacker Neuson dealer/service center.

The engine/equipment must be presented to an authorized Wacker Neuson dealer/service center as soon as a problem exists. Contact Wacker Neuson Product Support Department (1-800-770-0957) or visit [wackerneuson.com](http://wackerneuson.com) to find a dealer/service center in your area, or to answer questions regarding warranty rights and responsibilities.

---

### How to Make a Claim

In the event that any emission-related part is found to be defective during the warranty period, you shall notify Wacker Neuson Product Support Department (1-800-770-0957, or [technical.support@wackerneuson.com](mailto:technical.support@wackerneuson.com), or [wackerneuson.com](http://wackerneuson.com)), and you will be advised of the appropriate dealer/service center where warranty repair can be performed. All repairs qualifying under this limited warranty must be performed by an authorized Wacker Neuson dealer/service center.

You must take your Wacker Neuson engine/equipment along with proof of original purchase date, at your expense, to the authorized Wacker Neuson dealer/service center during their normal business hours.



## Emission Control Systems Information and Warranty—Gasoline

For owners located more than 100 miles from an authorized dealer/service center (excluding the states with high-altitude areas as identified in 40 CFR Part 1068, Appendix III), Wacker Neuson will pay for pre-approved shipping costs to and from an authorized Wacker Neuson dealer/service center.

Claims for repair or adjustment found to be caused solely by defects in material or workmanship will not be denied because the engine/equipment was not properly maintained and used.

The warranty repairs should be completed in a reasonable amount of time, not to exceed 30 days.



# Emissions Control Systems Information and Warranty

## 12 Emissions Control Systems Information and Warranty

| CRT48-37V                  |                   |
|----------------------------|-------------------|
| System Covered             | Components        |
| Evaporative control system | Fuel tank         |
|                            | Fuel cap          |
|                            | Fuel line         |
|                            | Fuel vent fitting |

See the supplied engine owner's manual for the applicable exhaust emission warranty statement.

---

| CRT48-57K                  |                     |
|----------------------------|---------------------|
| System Covered             | Components          |
| Exhaust system             | Pipe-engine         |
|                            | Catalytic converter |
| Evaporative control system | Fuel tank           |
|                            | Fuel cap            |
|                            | Fuel line           |
|                            | Fuel return fitting |

See the supplied engine owner's manual for the applicable exhaust emission warranty statement.

### 12 Emissions Control Systems Information and Warranty

#### Limited Defect Warranty Period for Wacker Neuson Emission Control Systems

The warranty period for this engine/equipment begins on the date of sale to the initial purchaser and continues for a period of 3 years or 2500 hours of operation (whichever comes first). For the warranty terms for your specific engine/equipment, visit [wackerneuson.com](http://wackerneuson.com).

Any implied warranties are limited to the duration of this written warranty.





# SAFETY MANUAL

FOR OPERATING AND MAINTENANCE PERSONNEL

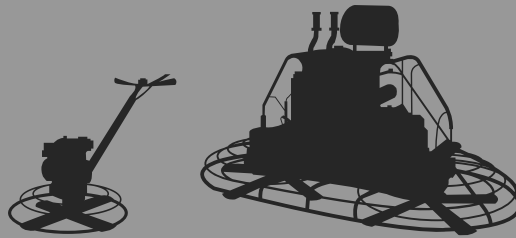

## Table of Contents

|                                   |    |
|-----------------------------------|----|
| Acknowledgment.....               | 2  |
| Foreword .....                    | 3  |
| Safety Alerts.....                | 4  |
| A Word to the User/Operator ..... | 5  |
| Follow a Safety Program.....      | 6  |
| Prepare for Safe Operation.....   | 10 |
| Start Safely.....                 | 17 |
| Operate Safely .....              | 19 |
| Shut Down Safely .....            | 21 |
| Perform Maintenance Safely.....   | 22 |
| Final Word to the User .....      | 35 |

## Acknowledgment

We wish to thank the members of the Association of Equipment Manufacturers for their invaluable contributions in preparing this Safety Manual.

### NOTICE OF COPYRIGHT PROTECTION

Copyright 2017, by the Association of Equipment Manufacturers. All rights reserved. This work may not be reproduced or disseminated in whole or in part by any means without the prior written permission of the Association of Equipment Manufacturers.

# Foreword

This safety manual is intended to point out some of the basic safety situations that may be encountered during the normal operation and maintenance of your trowel and to instruct you in safety practices for dealing with these conditions. This manual is **NOT** a substitute for the manufacturer's operating manual(s).

Additional precautions may be necessary, or some instructions may not apply, depending on equipment, attachments and conditions at the job site or in the service area. The manufacturer has no direct control over equipment application, operation, inspection, or maintenance. Therefore, it is **YOUR** responsibility to use good safety practices in these areas.

The information provided in this manual supplements the specific information about your trowel that is contained in the manufacturer's operating manual(s). Other information that may affect the safe operation of your machine may be contained in the following:

- Safety signs
- Insurance requirements
- Employer safety and training programs
- Safety codes
- Local, state/provincial, and federal laws, rules, and regulations

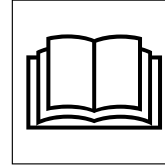

**Read and understand manuals before operating**

**IMPORTANT!** Before you operate this machine, make sure you have the manufacturer's manual(s) for this trowel and all attachments. If the manufacturer's manual(s) are missing, obtain replacements from your employer, equipment dealer, or directly from the manufacturer. Keep this safety manual and the manufacturer's manual(s) with the machine at all times. Read and understand all manuals.

Safety videos and other training resources are available from some manufacturers and dealers. Operators are encouraged to periodically review these resources.

3

## Safety Alerts

### Safety Alert Symbol

This Safety Alert Symbol means:  
**"Attention! Stay alert! Your safety is involved!"**



The Safety Alert Symbol identifies important safety messages on equipment, safety signs, in manuals, or elsewhere. When you see this symbol, be alert to the possibility of death or personal injury. Carefully read the message that follows and inform other operators. Follow instructions in the safety message.

### Signal Words

Signal words are distinctive words that are typically found on safety signs on the concrete power trowels and other job site equipment. These words may also be found in this manual and the manufacturer's manual(s). These words are intended to alert the operator to a hazard and the degree of severity of the hazard.



**DANGER** indicates a hazardous situation that, if not avoided, will result in death or serious injury.



**WARNING** indicates a hazardous situation that, if not avoided, could result in death or serious injury.



**CAUTION** indicates a hazardous situation that, if not avoided, may result in minor or moderate injury.



**NOTICE** is used to address practices not related to physical injury.



# A Word to the User/Operator

It is **YOUR** responsibility to read and understand this safety manual and the manufacturer's manual(s) before operating this equipment. This safety manual takes you step by step through the working day.

Graphics have been provided to help you understand the text.

Hazard recognition and accident prevention depend upon you being alert, careful, and properly trained in the inspection, operation, transport, maintenance, and storage of this equipment.

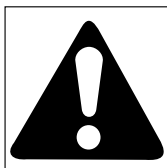

Read and understand all safety signs – replace damaged signs

Remember that **YOU** are the key to safety. Good safety practices not only protect you but also protect the people around you. Study this manual and the manufacturer's operating manual(s) for the specific machine. Make them a working part of your safety program. Keep in mind that this safety manual is written only for concrete power trowels.

After studying the manufacturer's operating manual(s) and this safety manual, please contact the equipment manufacturer with any remaining questions.

**Practice all usual and customary safe working precautions and remember:**

**Safe operation is up to you!**

**You can prevent death or serious injury caused by unsafe work practices!**

5

## Follow a Safety Program

### For Safe Operation

You must be a qualified and authorized operator for safe operation of this trowel. You must clearly understand the written instructions supplied by the manufacturer, be trained—including actual operation—and know the safety rules and regulations for the job site. It is a good safety practice to point out and explain safety signs and practices to others, and to make sure they understand the importance of following these instructions.



Never operate while impaired by alcohol or drugs

**⚠ WARNING!** Death or serious injury could result from operating machinery while impaired by drugs or alcohol. Drugs and alcohol affect operator alertness, coordination, and the ability to safely operate the equipment. **Never operate the trowel while impaired by use of alcohol or drugs. Never knowingly allow anyone to operate the machine when their alertness or coordination is impaired.**

An operator taking prescriptions or over-the-counter medication must consult a medical professional regarding any side effects of the medication that would hinder their ability to safely operate this equipment.

### Be Alert!

Know where to get assistance. Keep emergency numbers for doctors, ambulance service, hospital, and fire department near your telephone. Know how to use a first aid kit and fire extinguisher/fire suppression system; know their location and practice getting to them. Ensure they have been properly tested and maintained.

Let others know where you will be working, and what time you will be returning. In case of an emergency, you want others to know where to find you.

### Be Aware!

Take advantage of training programs offered.

Know the proper response to a fire or chemical spill on your trowel.

# Follow a Safety Program

## Be Careful!

Human error is the result of many factors: carelessness, fatigue, sensory overload, preoccupation, unfamiliarity with the machine or attachments, or drugs and alcohol, to name a few. You can avoid death or serious injury caused by these and other unsafe work practices. Be careful; never assume accidents cannot happen to you.

For your safety and the safety of others, act safely and encourage your fellow workers to act safely as well.

## Protect Yourself

Wear all the personal protective clothing and Personal Protective Equipment (PPE) issued to you or called for by job conditions.

You may need:

- Hard hat
- Safety shoes
- Safety glasses, goggles, or face shield
- Heavy duty gloves
- Hearing protection
- Reflective clothing
- Wet weather gear
- Respirator or filter mask

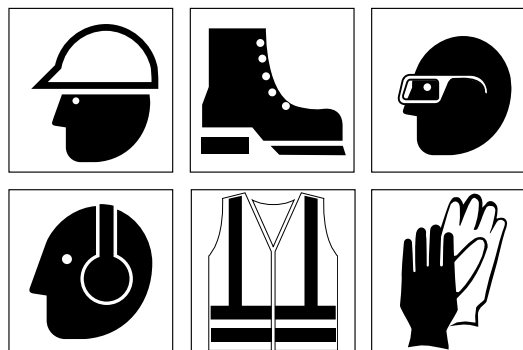

Wear whatever is needed to protect yourself—don't take chances.

**⚠ WARNING!** Avoid death or serious injury from entanglement. **Do not wear loose or frayed clothing or accessories that could catch on moving parts.** Examples of items to avoid include flopping cuffs, dangling neckties and scarves, wallets attached to chains, jewelry and wrist watches.

7

# Follow a Safety Program

## Know the Rules

Most job sites have rules governing equipment use and maintenance. Before you start work at a new location, check with the supervisor or safety coordinator. Ask about the rules you will be expected to obey.

OSHA enforces federal laws within the United States that apply to the safe operation, application, and maintenance of equipment on some job sites. It is the employer's responsibility to comply with these laws. A federal representative may periodically inspect a job site to see that these laws are being followed.

There may be other local, state/provincial, federal laws or international organizations that regulate the use of this equipment, along with specific job site or employer rules. It is important that you know and comply with all applicable laws and rules, **including those requiring operator training and certification.**

**These are some of the rules you must work by:**

- Only qualified and authorized individuals may operate this equipment.
- Inspect your machine and attachments before each use as specified by the manufacturer and your employer.

- Know the operating characteristics of your equipment. Do not misuse it.
- Wear proper clothing and PPE. Check that others are also wearing appropriate clothing.
- All shields, guards, air filters, access panels, and doors must be properly installed before each use.
- Know the rules regarding traffic at your job site. Know what all signs, flags, and markings mean. Know hand, flag, horn, whistle, siren, or bell signals, if used.
- Never modify or remove any part of the machine (except for qualified service personnel; then make sure the part is re-installed or replaced if defective or worn out).



**Know and understand rules of operation**

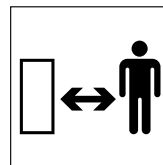

**Keep bystanders away**

8

# Follow a Safety Program

- **Never allow children to play near, ride on or operate the equipment.**
- Keep bystanders away from the machine during operation.
- Know the work area before you use the equipment. Be aware of possible hazards.
- Only use attachments and parts that are approved by the manufacturer.
- Follow all safe shutdown instructions (See page 21, **Shut Down Safely**).

## Know the Equipment

Read and understand the DANGER, WARNING, CAUTION, and NOTICE safety labels and other informational signs on the machine, the attachments, and in the manufacturer's operating manual(s). Ask your supervisor or dealer to explain any information you do not understand. Failure to obey safety instructions could result in death or serious injury.

### Know the following about your equipment:

- Function, purpose, and use of all controls
- Correct operation speeds
- How to quickly stop equipment in an emergency
- Rated operating capacity

- Know the meaning of all identification symbols on the controls and gauges
- Know the location and type of emergency shut-down control the trowel is equipped with
- Never start or operate the trowel without protective guards and panels in place
- Know the capabilities and limitations of the trowel

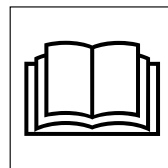

**Read and understand manuals before operating**

## Dust Precaution

Some dust created by construction activities may cause silicosis or respiratory harm.

Your risk of exposure varies depending on how often you do this type of work. To reduce your risk, work in a well ventilated area, use a dust control system, and wear approved personal safety equipment such as a dust/particle respirator designed to filter out microscopic particles.

9

# Prepare for Safe Operation

## Load and Unload Safely

### Precautions

- Power trowels are heavy and awkward to move around.
- Do not attempt to lift the ride-on trowel by the guard rings.
- Use proper heavy lifting procedures.
- Keep all non-essential personnel clear of the area.
- Never lift the trowel over areas where people are standing or working.
- Remove tools and loose items before lifting.
- Make sure the crossbars on the safety catches are in good condition if so equipped.
- Always consult the machine's operator's manual for the best and proper lifting, loading, and unloading methods.

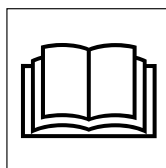

**Read and understand manuals before loading and unloading**

### Walk-Behind Trowels

Some walk-behind trowels can be lifted or moved by two people utilizing lifting tubes or other special attachments. Generally however, they must be lifted using lifting bales (special lifting brackets), or other specific lifting points provided by the manufacturer, and cranes, hoists, or forklifts. Be certain any lifting devices used have adequate capacity.

### Ride-On Trowels

Ride-on trowels are very heavy. They require heavy-duty lifting devices such as cranes or heavy-duty hoists to lift them on and off the concrete slab.

Be certain any lifting devices used have adequate capacity. Some ride-on trowels are equipped with lifting bosses that are used with specialized apparatus to assist in moving the trowels around. Use extreme care when lifting or moving a ride-on trowel.

# Prepare for Safe Operation

## Check and Use All Available Safety Devices

To protect you and others around you, your machine may be equipped with the safety equipment listed below. Additional equipment may be required or some items may not apply, depending on attachments used, job site conditions, or applicable job site rules. Check that each required item is securely in place and in operating condition:

- Emergency stop switch or other “Shut-Down” devices
- Guards, Shields & Panels
- Alarms or Warning Lamps
- Drain Covers, Plugs, and Caps
- Pressure Relief Devices
- Lights
- Special enclosures or accessories required for specific applications or job site conditions
- Safety Signs

Use them! Never remove or disconnect any safety device.

## Check the Machine

Before beginning your work day, inspect the machine and have all systems in good operational condition.

- Perform daily and periodic service procedures as instructed by the equipment manufacturer.
- Check for broken, missing, loose, or damaged parts. Make necessary repairs.



Inspect the machine before each work day

- Keep handholds clean and free of grease, oil, dirt, snow or ice.
- Ensure shielding is properly installed and in good condition. Repair or replace if damaged or missing.
- Ensure all tools or loose objects are removed or securely fastened before operating the machine.

11

# Prepare for Safe Operation

## Hydraulic Fluid Injection Hazard

**▲ WARNING!** Accidental injection of pressurized fluid into the hands or body is dangerous and could result in death or serious injury. **Use caution when checking hydraulic leaks as pressurized hydraulic fluid has enough force to penetrate skin, causing serious personal injury.**

If a leak is discovered:

- Ensure engine is turned off; relieve pressure in hydraulic circuit.
- Wear proper hand and eye protection.
- Visually examine the hydraulic hose or fluid lines in the vicinity of the leak for breaks or cracks. **Do not** use your hand to check for leaks.
- Repair or replace hydraulic lines per manufacturer's recommendation.

Fluid injection injuries are not always obvious. Victims have reported such injuries feel like a bee sting or splinter under the skin. If you suspect you have a fluid injection injury, do not take chances. Seek proper medical care immediately. If any fluid is injected into the skin, it must be surgically removed within a few hours by a doctor familiar with this type of injury.



Pressurized fluid can inject into the body

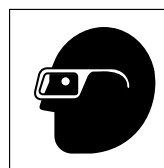
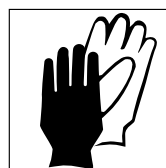

Wear proper hand and eye protection

12

## Prepare for Safe Operation

### Check the Cooling System

When checking the cooling system, make sure the engine is turned off and is cool. Remove the key to prevent fans from unexpectedly starting. Ensure the coolers and engine compartment are clean and free from debris, which could ignite and cause a fire.

If the machine is air-cooled, be sure the cooling unit has an unobstructed air flow. If it is liquid-cooled, check coolant level (at overflow tank, if provided).

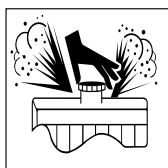

Allow radiator to cool before removing cap slowly

**⚠ WARNING!** Allow the radiator to cool before checking the level. Hot radiator fluids could escape as steam and burn you. (See page 27, **Engine Coolant Hazards.**)

### Use Caution When Fueling

**⚠ WARNING!** Avoid injury from fire or explosion. **Never fill the fuel tank with the engine running, while smoking or when near an open flame.**

Never overfill the tank or spill fuel. If fuel is spilled, clean it up immediately.

Be sure to use the correct type and grade of fuel.

Ground the fuel funnel or nozzle against the filler neck to prevent sparks that could ignite fuel vapors. Be sure to replace the fuel fill cap (if equipped) when you are done.



No smoking and no open flames in flammable/explosive atmospheres

13

## Prepare for Safe Operation

### Ultra-Low Sulfur Diesel (ULSD) Fuel Hazard

#### Avoid Static Electricity Risk When Fueling

**⚠ WARNING!** Ultra-Low Sulfur Diesel (ULSD) poses a greater static ignition hazard than earlier diesel formulations. Avoid death or serious injury from fire or explosion; **consult with your fuel or fuel system supplier to ensure the delivery system is in compliance with fueling standards for proper grounding and bonding practices.**

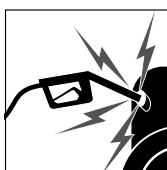

Static discharge during fueling can cause explosion

**⚠ WARNING!** Exhaust fumes from diesel, gasoline or LP gas engines can kill. **Do not breath exhaust fumes from any kind of engine.**

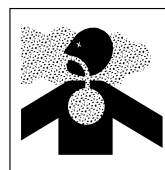

Ventilate work area

#### Operating in Flammable/Explosive Atmospheres

**⚠ WARNING!** A trowel must not be operated in flammable or explosive atmospheres. Use in explosive atmospheres can result in fires and/or explosions which could cause serious injury or death.



Do not operate in explosive/flammable atmosphere

### Follow Safe Operating Practices

#### Exhaust Fumes in a Closed Space Can Kill

Vent exhaust and assure a flow of fresh air when an internal combustion engine is used in a closed space.

## Prepare for Safe Operation

### Avoid Crystalline Silica (quartz) Dust

**⚠ WARNING!** Avoid exposure to dust containing crystalline silica particles. This dust can cause serious injury to the lungs (silicosis).

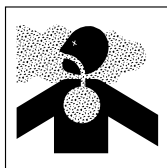

Avoid silica dust

Because crystalline silica is a basic component of sand and granite, many activities at construction sites produce dust containing crystalline silica. Trenching, sawing and boring of material containing crystalline silica can produce dust containing crystalline silica.

If dust which contains crystalline silica is present there are guidelines which should be followed.

1. Be aware of the health effects of crystalline silica and that smoking adds to the damage.
2. Be aware of and follow OSHA (or other) guidelines for exposure to airborne crystalline silica.
3. Know the work operations where exposure to crystalline silica may occur.
4. Participate in air monitoring or training programs offered by the employer.
5. Be aware of and use optional equipment controls such as water sprays, local exhaust ventilation, and enclosed cabs with positive pressure air conditioning.
6. Where respirators are required, wear a respirator approved for protection against crystalline silica-containing dust. Do not alter the respirator in any way. Workers who use tight-fitting respirators cannot have beards/mustaches which interfere with the respirator seal to the face.
7. If possible, change into disposable or washable work clothes at the worksite; shower and change into clean clothing before leaving the worksite.
8. Do not eat, drink, use tobacco products, or apply cosmetics in areas where there is dust containing crystalline silica.
9. Store food, drink and personal belongings away from the work area.
10. Wash hands and face before eating, drinking, smoking, or applying cosmetics after leaving the exposure area.

15

## Prepare for Safe Operation

### Know the Working Area

Learn as much about your working area as possible.

#### Check at Ground or Floor Level

Thoroughly check the area for unusual or dangerous conditions, such as tools, or items that may damage the trowel or be propelled by the trowels rotating blades. Note where pipes and forms are located. Locate and mark protrusions (rebar, anchor bolts, floor drains, etc.) in the concrete.

### Plan Your Work

Know in advance the conditions likely to be encountered, and plan for any likely emergency.

#### Getting on and off a Ride-On Trowel

If operating a ride-on trowel, mount and dismount carefully. Use the steps and hand holds provided. Do not use control levers as hand holds and never use guard rings as steps. Watch for surfaces that may be slippery. Never jump off a ride-on trowel.

### Operating on an Elevated Deck (Multi-Story Operation)

Consult local/state regulations before you operate equipment on an elevated deck. If operating on an elevated deck, ensure perimeter safety cabling of proper size and strength is in place. Do not operate the trowel close to the edge of the deck.

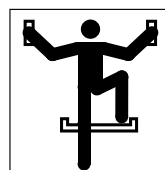

Use three points of contact when mounting and dismounting

# Start Safely

## Warn Personnel Before Starting

Before starting, walk completely around the machine. **Make sure no one is on it or close to it.** Let others know you are starting up and don't start until everyone is completely clear of the machine. As the equipment operator, you are responsible for the safe use of the machine, so always make sure you have communicated your work plans to others on the site.



Before starting,  
walk completely  
around trowel

Check the trowel thoroughly at delivery for any shipping damage.

Locate the trowel in an accessible location, as close to the work site as possible.

Secure the trowel after it is placed in its intended operating position so it does not tip, roll, slide or fall.

## Starting the Engine

**⚠ WARNING! Never attempt to start the engine by shorting across starter terminals.** Serious injury or death may result.

Know the exact starting procedure for your machine. See the manufacturer's operating manual(s) for starting.

- Familiarize yourself with warning devices, gauges and operating controls.
- Make sure controls are in the neutral/locked position.
- Clear the area of all persons.
- Start the engine following the instructions in the manufacturer's operating manual(s).
- If necessary to run the engine or operate the machine in an enclosed area, ensure there is adequate ventilation.

**⚠ WARNING! Never operate the machine without adequate ventilation. Exhaust fumes can kill. Do not breathe exhaust fumes!**

For a walk-behind (pedestrian operated) trowel machine, make sure that a circular area with a minimum radius equal to the length of the machine is clear. This will ensure safety of personnel around the machine.

17

# Start Safely

## Starting Aids

If you have trouble starting the engine and need to use jumper cables, follow the instructions in manufacturer's operating manual(s). **Jump-starting is a two-person operation.** The operator must be in the operator's seat when jump-starting so the machine will be under control when the engine starts.

**⚠ WARNING!** Improper jump-starting procedures may cause serious injury or death from a battery explosion or a run-away machine. **Always use proper jump-starting procedure.** (See page 29, **Battery Hazards.**)

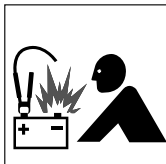

To avoid explosion,  
follow proper jump-  
starting procedures

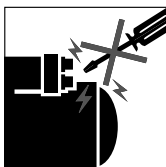

Never start engine  
by shorting across  
starter terminals

Ether/cold start fluid is HIGHLY FLAMMABLE. Before using it, always read the instructions on the ether/cold start fluid container and the instructions in the manufacturer's operating manual(s).

**⚠ WARNING!** Avoid injury from explosion or fire. If the engine is equipped with a glow plug pre-heater or other intake manifold type pre-heater, follow manufacturer's instructions before using ether/cold start fluid.

## After Starting Engine

Observe gauges, instruments, and warning lights to assure that they are functioning and their readings are within the operating range.

## Run an Operating Check

Do not use a machine that is not in proper operating condition. It is your responsibility to check the condition of all systems and to run the check in a safe area.

18

# Operate Safely

## Walk-Behind Trowels

- Ensure that the operator is familiar with the trowel and is trained on its operation.
- Do not start or operate the trowel if the drive train will not disengage. Centrifugal force between the trowel and surface when starting can cause uncontrolled handle movement that can cause serious injury. The handle must not move while pulling the engine recoil starter.
- Visually check to be sure that the blades are free of obstructions and the area is clear for operation.
- For trowels that use this feature, ensure that the emergency stop switch is in the ON position.
- Move the throttle to the idle position.
- Switch the engine ON/OFF switch to the ON position.
- Never place your foot on the ring guard when starting the engine or severe injury can occur if your foot slips through the ring guard as the blades start to spin.
- While firmly holding the handle with one hand, start the engine following the guidelines in the engine manufacturer's instruction manual.
- Hold the handle bar firmly with both hands while the trowel is "throttled-up".

- If control of the trowel is lost, stay clear and do not attempt to regain control until the trowel has stopped moving. Depending on the engine speed, the trowel handle can swing around before it stops completely.

## Ride-On Trowels

- Ensure that the operator is familiar with the trowel and is trained on its operation.
- Ensure the operator is well rested and not fatigued, is alert, and not impaired in any way (medications, drugs, alcohol, etc.).
- Adjust the seating if necessary and get into a comfortable position where all controls are accessible.
- Visually check to be sure that the blades are free of obstructions and the area is clear for operation.
- Start the trowel following the instructions in the engine manufacturer's operation manual. For diesel powered trowels, follow the instructions for glow plug and cold start operation.
- Observe any gauges and warning lights to ensure they are functioning and their readings are within the manufacturer's normal operating range.
- Check operation of controls. Make certain they operate properly.

19

# Operate Safely

## Electrical Equipment

Some walk-behind trowels are powered by electric motors. Electric motors and components present special hazards during operation. Read the operator's manual.

- Never operate a trowel with a damaged or worn electrical cord. When using an extension cord, be sure to use one heavy enough to carry the current load. When trowel is used outdoors, use only extension cords that are marked for outdoor use.
- Use only appropriate extension cords that have grounding-type plugs and receptacles that accept the machine's plug.
- Use an electrically powered trowel that has been built in accordance with the requirements of the National Electrical Code (NFPA-70) and has been approved by a Nationally Recognized Test Lab.



- Keep all electrical cords away from rotating components, heat, oil, and sharp edges to avoid damaging them.
- Avoid body contact with grounded surfaces such as pipes, metal railings, radiators and metal ductwork.
- Always check the power supply before running the trowel. Using the wrong voltage supply will damage the motor.
- Always make sure the motor switch is OFF or in the stop position before plugging the trowel into the power supply.
- Do not operate an electric powered trowel in the rain or snow. Keep the motor, switch, and electrical cords dry.
- Never operate the trowel in areas exposed to flammable or explosive liquids or gases. Sparks could ignite fumes.



# Shut Down Safely

## Storage

Always store equipment properly when it is not being used. Equipment should be stored in a clean, dry location out of reach of children.

**⚠ WARNING!** Avoid death or serious injury. **Never leave a machine unattended with the engine running.**

## Safe Shutdown

The detailed shutdown procedure is given in your manufacturer's manual(s). In general, this includes:

- Stop machine.
- Position controls in neutral or locked position.
- Idle engine for short cool-down period.
- Stop engine and remove ignition key (if equipped).
- Cycle hydraulic controls to eliminate pressure.
- Lock covers and enclosures.
- Shut off master electric switch (if equipped).

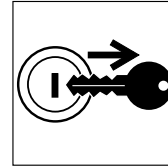

**Shut engine off,  
remove key**

21

# Perform Maintenance Safely

## Know What You're Doing

Maintenance on this type of machine is not for inexperienced or untrained personnel. It can be hazardous unless performed properly. Be sure you have the necessary skill, information, correct tools, and proper equipment to do the job safely.

Be sure to maintain the equipment according to the manufacturer's instructions. Regularly check the operation of the protective and safety devices.

**Do not** perform any work on a machine unless you are authorized and qualified to do so.

If you have been authorized to perform maintenance, **read the manufacturer's operating and service manual(s)**. Study the instructions: check the lubrication charts, examine all the instruction messages on the machine.

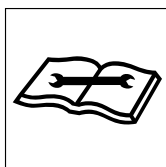

**Maintain equipment**

## Protect Yourself

Wear all the personal protective clothing and PPE issued to you or called for by job conditions.

You may need:

- Hard hat
- Safety shoes
- Safety glasses, goggles or face shield
- Heavy duty gloves
- Hearing protection
- Reflective clothing
- Wet weather gear
- Respirator or filter mask

Wear whatever is needed to protect yourself. Do not take chances.

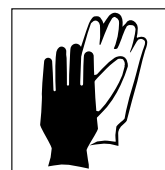
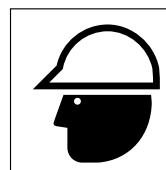

# Perform Maintenance Safely

**⚠ WARNING!** Avoid death or serious injury from entanglement. **Do not wear loose clothing or accessories. Stay away from all rotating components when the engine is running.** Contact, wrapping or entanglement with rotating or moving parts could result in death or serious injury.

Wear a rubber apron and rubber gloves when working with corrosives. Wear gloves and safety shoes when handling wooden blocks or sharp-edged metal.

Always use safety glasses, goggles or a face shield. They provide eye protection from fluids under pressure, during grinding and while servicing batteries. Protection is also needed from flying debris, liquids and loose material produced by equipment, tools and pressurized air/water.

Wear a face shield and follow manufacturer's instructions when you disassemble spring-loaded components or work with battery acids. Keep pockets free of all objects that could fall out and drop into machinery.

Handle tools and heavy parts sensibly, with regard for the safety of yourself and others. Lower items; don't drop them.

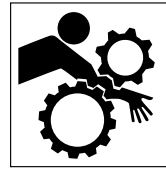

**Avoid rotating parts**

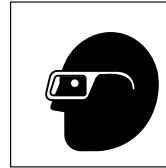

**Wear eye protection**



**Do not  
loosen  
radiator cap  
until cool**

23

# Perform Maintenance Safely

## Prepare the Work Area

- Position the machine in a level area out of the way of other working equipment.
- Make sure there is adequate light, ventilation and clearance.
- Remove oil, grease or water to eliminate any slippery surfaces.
- Clean around the area to be serviced to minimize contamination.



**Avoid falls, clean  
slippery surfaces**

## Prepare the Machine

Stored energy sources (electrical, mechanical, hydraulic, pneumatic, chemical, thermal, etc.) must be controlled or reduced to a practical minimum before performing any maintenance, repair, or service procedures.

**⚠ CAUTION!** Load and unload machinery using proper procedures. (See page 10, **Load and Unload Safely.**)

Safety practices to prevent potential injuries from energy-releasing sources include:

- Place controls in NEUTRAL or LOCKED position before shutting off engine.
- Allow all moving parts to stop.
- Shut off engine.
- Follow your manufacturer's recommendation for relieving hydraulic system pressure.
- Lock ignition, remove key (if equipped) and take it with you.
- Look and listen for evidence of moving parts before dismounting.
- Shut off master electrical switch (if equipped).
- Securely support or block up machine before working underneath machine or other lifted components.
- Securely support, block up, or lock up other components with approved locking devices before working near or underneath them.
- Relieve pressure before disconnecting or disassembling any pressurized system.
- Block or relieve spring pressure before disassembling any spring-loaded mechanism.
- Avoid flames, sparks, or smoking near any fuel, hydraulic fluid or other flammable material such as spraying debris.

# Perform Maintenance Safely

Attach a “DO NOT OPERATE” warning tag to the control levers. Lockout/tagout the unit according to the manufacturer’s operating manual(s). If there is a key, remove it and take it with you.

Install approved support device(s) when working under or near raised equipment.

Remove only guards or covers that provide access to the area being serviced. Replace all guards and covers when work is complete.

Do not operate the machine with gaurds removed.

**⚠ WARNING!** Avoid injury or death. **Never work on machinery with the engine running unless instructed by the manufacturer’s manual(s) for specific service.**

## Trowel Maintenance and Repair

**MAKE SURE** the trowel is disconnected from the power source or the appropriate circuits are dead and OSHA Lockout/Tagout is applied before doing any maintenance or repair work on the trowel.



## Trowel Blades, Pans and Attachments

- Do not attempt to clean, service or perform adjustments on the trowel while it is running.
- Do not remove blades or pans while the trowel is hanging overhead. Always support the trowel securely on a flat, level surface before changing blades or pans.
- Always handle blades and pans carefully. Worn blades or pans may develop sharp edges that can cause serious cuts.
- Always replace worn or damaged parts with service parts designated by the manufacturer.
- Replace blades and pans as a complete set – even if only one blade or pan is showing wear or damage. They can wear differently depending on different jobs, and a difference in blade size will damage the finish of the slab surface.
- Only use manufacturer approved polishing and brush attachments.

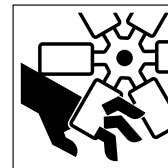

# Perform Maintenance Safely

## Common Maintenance Safety Practices

### Use Proper Ventilation

Never run an engine in an enclosed area without an approved ventilation system.

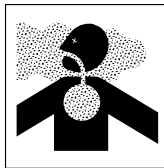

**⚠ WARNING!** Exhaust fumes contain carbon monoxide which could be deadly if inhaled. **Never operate any type of engine without proper ventilation. EXHAUST FUMES CAN KILL.**

A feeling of tiredness, or nausea, is an indication of being overcome by exhaust. Shut the engine off immediately if this occurs.

## Fuel Hazards

**⚠ WARNING!** Avoid serious injury or death. **Always use approved fuel containers and/or fuel dispensing equipment to reduce the risk of explosion or fire.**

Always observe these practices to reduce the possibility of a serious accident:

- Shut off engine and ignition during refueling.
- Turn off all electrical switches.
- Ground the fuel nozzle against the filler neck.
- Keep sparks and open flames away from fuel. Do not smoke while refueling or when handling fuel containers.
- Do not cut or weld on or near fuel lines, tanks or containers.
- Do not overfill the tank or spill fuel. Clean up spilled fuel immediately. Clean spills immediately.



# Perform Maintenance Safely

## Ultra-Low Sulfur Diesel (ULSD) Hazard

**⚠ WARNING!** Ultra-Low Sulfur Diesel (ULSD) poses a greater static ignition hazard than earlier diesel formulations with higher sulfur content. Avoid death or serious injury from fire or explosion; **consult with your fuel or fuel system supplier to ensure the delivery system is in compliance with fueling standards for proper grounding and bonding practices.**

## Engine Coolant Hazards

**⚠ WARNING!** Avoid serious injury or death. Liquid cooling systems build up pressure as the engine gets hot, so **use extreme caution before removing the radiator cap.**

- Stop the engine and wait for the system to cool.
- Wear protective clothing and safety glasses.
- Turn the radiator cap slowly to the first stop to allow the pressure to escape before removing completely.

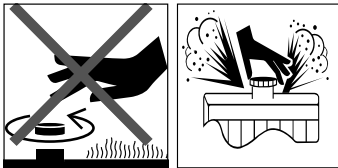

**Allow radiator to cool before removing cap slowly**

## Engine Coolant Hazards (cont.)

**⚠ CAUTION!** Before replacing engine coolant, refer to the manufacturer's operating manual(s) for direction. Using incorrect coolant type may cause overheating and increase safety risks.

## Hydraulic System Hazards

Be sure to follow manufacturer's instructions for relieving fluid pressure before performing any maintenance. The hydraulic system is pressurized whenever the engine is on and may hold pressure even after the engine is shut off. Cycle hydraulic controls, including auxiliary hydraulic control (if equipped), after the engine is shut off.



**Check for leaks and inspect hoses**

27

# Perform Maintenance Safely

## Hydraulic System Hazards (cont.)

During inspection of the hydraulic system:

- Wait for fluid to cool before disconnecting the lines. Hot hydraulic fluid can cause **severe burns**.
- Wear appropriate eye protection. Hydraulic fluid can cause permanent eye injury.
- When venting or filling the hydraulic system, loosen the filler cap slowly and remove it gradually.
- **Never** reset any relief valve in the hydraulic system to a pressure higher than recommended by the manufacturer.

## Hydraulic Fluid Injection Hazard

**⚠ WARNING!** Accidental injection of pressurized fluid into the hands or body is dangerous and could result in death or serious injury. **Use caution when checking hydraulic leaks as pressurized hydraulic fluid has enough force to penetrate skin, causing serious personal injury.**

If a leak is discovered:

- Ensure engine is turned off; relieve pressure in hydraulic circuit.
- Wear proper hand and eye protection.

- Visually examine the hydraulic hoses or fluid lines in the vicinity of the leak for breaks or cracks. **Do not** use your hand to check for leaks.
- Repair or replace hydraulic lines according to the manufacturer's recommendations.

Fluid injection injuries are not always obvious. Victims have reported such injuries feel like a bee sting or splinter under the skin. If you suspect you have a fluid injection injury, do not take chances. Seek proper medical care immediately. If any fluid is injected into the skin, it must be surgically removed within a few hours by a doctor familiar with this type of injury.

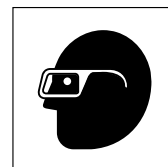

**Wear eye protection**



**Pressurized fluid can inject into the body**

28

# Perform Maintenance Safely

## Battery Hazards

The liquid in batteries contains acid, which is a POISON and could cause SEVERE CHEMICAL BURNS.

Avoid injury:

- Wear a face shield to prevent contact with your eyes.
- Wear chemical-resistant gloves and clothing to keep electrolyte off your skin and regular clothing.

**⚠ WARNING!** Electrolyte will damage eyes or skin on contact. **Always wear a face shield to avoid electrolyte in eyes.**

If liquid from the battery contacts your eyes, flush immediately with clean water and get medical attention. Wear chemical-resistant gloves and protective clothing to keep liquid off your skin. If liquid contacts exposed skin or clothing, wash off immediately with clean water. If liquid is ingested, drink large quantities of water or milk. DO NOT induce vomiting. Seek medical attention immediately.

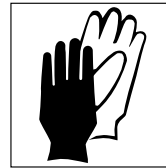

Wear hand protection

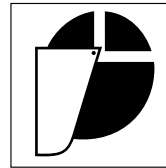

Wear face protection

29

# Perform Maintenance Safely

## Avoid Explosion

**⚠ WARNING!** Avoid serious injury from explosion. Lead-acid batteries produce extremely explosive gases especially when being charged. **Keep arcs, sparks, flames and lighted tobacco away.**

- Do not smoke near batteries.
- Keep them away from arcs, sparks and open flames.
- Provide adequate ventilation.

**Never** check the battery by placing a metal object across the battery posts. The resulting spark could cause an explosion.

**⚠ WARNING!** Avoid serious injury from battery explosion. **Do not charge a battery or jump-start the engine if the battery is frozen.**

Warm to 60°F (15.6°C) or the battery may explode and could cause serious injury.

Safety rules during battery jump-starting:

- Follow the instructions for proper battery jump-starting, as specified in the manufacturer's manual(s).
- Be sure the machines are not touching.
- Adhere to the polarity of the batteries and connections.

- Make the final cable connection to the engine or the farthest ground point away from the battery. Never make the final connection at the starter or dead battery. Sparks may ignite the explosive gases present at the battery.
- When disconnecting cables, remove the cables in reverse order of connection (e.g., final connection first).

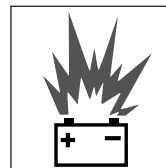

Avoid sparks and open flames near batteries



When jump-starting, observe polarity and make final connection at ground point

# Perform Maintenance Safely

## Complete Service and Repairs Before Machine is Released

Tighten all bolts, fittings, and connections to torques specified by the manufacturer.

Inspect for leftover components such as cotter pins, washers, locknuts, etc. after completing service. Replace any missing parts.



**Pressurized fluid  
can inject into  
the body**

Start the engine and check for leaks. (See page 27, **Hydraulic System Hazards**.) Operate all controls to make sure the machine is functioning properly. Test the machine if necessary. After testing, shut down and check the work you performed.

Recheck all fluid levels before releasing the equipment for operation.

All parts should be inspected during repair and replaced if worn, cracked or damaged. Excessively worn or damaged parts could fail and cause injury or death.

Install all guards, covers, and shields after servicing. Refill and recharge pressure systems only with manufacturer-approved or recommended fluids.



**Verify service work  
when completed**

## Notes

# Notes

33

# Notes

## Final Word to the User

You have just finished reading the AEM Concrete Power Trowel Safety Manual. It is impossible for this manual to cover every safety situation that you may encounter on a daily basis. Your knowledge of these safety precautions and your application to the basic rules of safety will help to build good judgment in all situations. Our objective is to help you develop, establish, and maintain good safety habits to make operating a concrete power trowel easier and safer for you.

Many pictorials in this safety manual can be downloaded at <http://pictorials.aem.org>.

For additional publications, visit our website at [www.safetymaterials.org](http://www.safetymaterials.org).

35



ASSOCIATION OF  
EQUIPMENT MANUFACTURERS

e-mail [safetymaterials@aem.org](mailto:safetymaterials@aem.org)  
[www.aem.org](http://www.aem.org)

This manual is one in a series on the safe operation of machinery, published by AEM.



To order AEM safety materials  
visit [www.safetymaterials.org](http://www.safetymaterials.org).





14 Schematics

Notes



14.2 Electrical Schematic Components: CRT 48-35L-PS

| Ref. | Description                              | Ref. | Description                   |
|------|--|------|-------------------------------|
| 1    | Battery                                  | 16   | Fuel cut-off solenoid         |
| 2    | Oil pressure switch (dual circuit)       | 17   | Starter motor                 |
| 3    | Key switch                               | 18   | Engine crank solenoid         |
| 4    | Oil pressure indicator light             | 19   | Glow plug fuse                |
| 5    | Operator presence switch (normally open) | 20   | Relay—safety system           |
| 6    | Throttle sense switch (normally closed)  | 21   | Voltage regulator             |
| 7    | Right front light                        | 22   | Alternator                    |
| 8    | Right rear light                         | 23   | Glow plug temperature sensors |
| 9    | Left rear light                          | 24   | Glow plugs                    |
| 10   | Left front light                         | 25   | Keyed power fuse              |
| 11   | Fuse—spray system                        | 26   | Glow plug relay               |
| 12   | Fuse—light circuit                       | 27   | 12V+ to Power Steer Circuit   |
| 13   | Light switch                             | 28   | Alternator light              |
| 14   | Spray pump switch                        | 29   | Coolant temperature light     |
| 15   | Spray pump motor                         | —    | —                             |

| Wire Colors |       |     |        |     |        |     |        |
|-------------|-------|-----|--------|-----|--------|-----|--------|
| BLK         | Black | RED | Red    | WHT | White  | ORG | Orange |
| GRN         | Green | TAN | Tan    | YEL | Yellow | BRN | Brown  |
| BLU         | Blue  | VIO | Violet | GRY | Gray   | PNK | Pink   |

14.3 Electrical Schematic: CRT 48-37V-PS

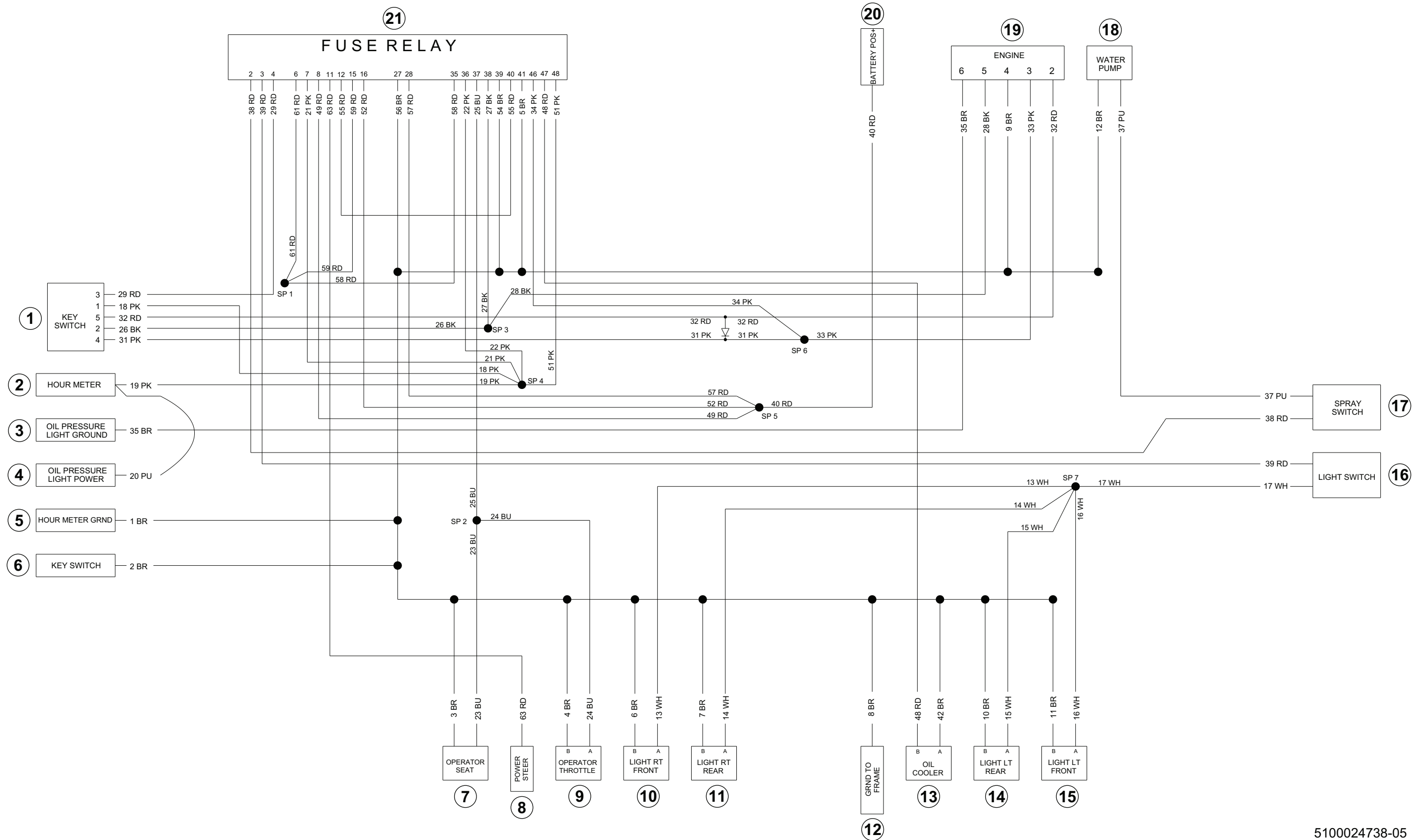

5100024738-05

14.4 Electrical Schematic Components: CRT 48-37V-PS

| Ref. | Description               | Ref. | Description      |
|------|---------------------------|------|------------------|
| 1    | Key switch                | 12   | Ground to frame  |
| 2    | Hour meter                | 13   | Oil cooler       |
| 3    | Oil pressure light ground | 14   | Light LT rear    |
| 4    | Oil pressure light power  | 15   | Light LT front   |
| 5    | Hour meter ground         | 16   | Light switch     |
| 6    | Key switch ground         | 17   | Spray switch     |
| 7    | Operator seat             | 18   | Water pump       |
| 8    | Power steer               | 19   | Engine           |
| 9    | Operator throttle         | 20   | Battery positive |
| 10   | Light RT front            | 21   | Fuse relay       |
| 11   | Light RT rear             | —    | —                |

| Wire Colors |       |            |        |           |        |           |          |
|-------------|-------|------------|--------|-----------|--------|-----------|----------|
| <b>BK</b>   | Black | <b>RD</b>  | Red    | <b>YL</b> | Yellow | <b>OR</b> | Orange   |
| <b>GN</b>   | Green | <b>TN</b>  | Tan    | <b>BR</b> | Brown  | <b>PU</b> | Purple   |
| <b>BU</b>   | Blue  | <b>VIO</b> | Violet | <b>CL</b> | Clear  | <b>SH</b> | Shield   |
| <b>PK</b>   | Pink  | <b>WH</b>  | White  | <b>GY</b> | Gray   | <b>LB</b> | Lt. blue |

14.5 Fuse/Relay Box Layout

|  |      | Position | Description             |       |    |   |  |  |   |   |   |  |   |   |  |  |  |  |  |    |   |   |   |   |   |    |  |  |  |  |    |    |  |  |  |  |    |    |  |  |  |  |    |    |      |      |  |  |    |    |   |       |  |  |    |    |      |      |  |  |    |    |      |      |      |      |    |    |   |       |   |       |    |  |      |      |      |      |  |  |    |    |    |    |  |          |            |
|--|------|----------|-------------------------|-------|----|---|--|--|---|---|---|--|---|---|--|--|--|--|--|----|---|---|---|---|---|----|--|--|--|--|----|----|--|--|--|--|----|----|--|--|--|--|----|----|------|------|--|--|----|----|---|-------|--|--|----|----|------|------|--|--|----|----|------|------|------|------|----|----|---|-------|---|-------|----|--|------|------|------|------|--|--|----|----|----|----|--|----------|------------|
| <table border="1" style="margin-left: auto; margin-right: auto;"> <tr> <td></td> <td>4</td> <td>3</td> <td>2</td> <td>1</td> <td></td> </tr> <tr> <td></td> <td>A</td> <td>B</td> <td>C</td> <td></td> <td>5</td> </tr> <tr> <td>8</td> <td></td> <td></td> <td></td> <td></td> <td></td> </tr> <tr> <td>12</td> <td>E</td> <td>F</td> <td>G</td> <td>H</td> <td>9</td> </tr> <tr> <td>16</td> <td></td> <td></td> <td></td> <td></td> <td>13</td> </tr> <tr> <td>20</td> <td></td> <td></td> <td></td> <td></td> <td>17</td> </tr> <tr> <td>24</td> <td></td> <td></td> <td></td> <td></td> <td>21</td> </tr> <tr> <td>28</td> <td>(30)</td> <td>(85)</td> <td></td> <td></td> <td>25</td> </tr> <tr> <td>32</td> <td>J</td> <td>(87A)</td> <td></td> <td></td> <td>29</td> </tr> <tr> <td>36</td> <td>(86)</td> <td>(87)</td> <td></td> <td></td> <td>33</td> </tr> <tr> <td>40</td> <td>(30)</td> <td>(85)</td> <td>(30)</td> <td>(85)</td> <td>37</td> </tr> <tr> <td>44</td> <td>L</td> <td>(87A)</td> <td>M</td> <td>(87A)</td> <td>41</td> </tr> <tr> <td></td> <td>(86)</td> <td>(87)</td> <td>(86)</td> <td>(87)</td> <td></td> </tr> <tr> <td></td> <td>48</td> <td>47</td> <td>46</td> <td>45</td> <td></td> </tr> </table> <p style="text-align: center; margin-top: 5px;">wc_gr014076</p> |      |          | 4                       | 3     | 2  | 1 |  |  | A | B | C |  | 5 | 8 |  |  |  |  |  | 12 | E | F | G | H | 9 | 16 |  |  |  |  | 13 | 20 |  |  |  |  | 17 | 24 |  |  |  |  | 21 | 28 | (30) | (85) |  |  | 25 | 32 | J | (87A) |  |  | 29 | 36 | (86) | (87) |  |  | 33 | 40 | (30) | (85) | (30) | (85) | 37 | 44 | L | (87A) | M | (87A) | 41 |  | (86) | (87) | (86) | (87) |  |  | 48 | 47 | 46 | 45 |  | <b>A</b> | Key 20 amp |
|  | 4    | 3        | 2                       | 1     |    |   |  |  |   |   |   |  |   |   |  |  |  |  |  |    |   |   |   |   |   |    |  |  |  |  |    |    |  |  |  |  |    |    |  |  |  |  |    |    |      |      |  |  |    |    |   |       |  |  |    |    |      |      |  |  |    |    |      |      |      |      |    |    |   |       |   |       |    |  |      |      |      |      |  |  |    |    |    |    |  |          |            |
|  | A    | B        | C                       |       | 5  |   |  |  |   |   |   |  |   |   |  |  |  |  |  |    |   |   |   |   |   |    |  |  |  |  |    |    |  |  |  |  |    |    |  |  |  |  |    |    |      |      |  |  |    |    |   |       |  |  |    |    |      |      |  |  |    |    |      |      |      |      |    |    |   |       |   |       |    |  |      |      |      |      |  |  |    |    |    |    |  |          |            |
| 8  |      |          |                         |       |    |   |  |  |   |   |   |  |   |   |  |  |  |  |  |    |   |   |   |   |   |    |  |  |  |  |    |    |  |  |  |  |    |    |  |  |  |  |    |    |      |      |  |  |    |    |   |       |  |  |    |    |      |      |  |  |    |    |      |      |      |      |    |    |   |       |   |       |    |  |      |      |      |      |  |  |    |    |    |    |  |          |            |
| 12   | E    | F        | G                       | H     | 9  |   |  |  |   |   |   |  |   |   |  |  |  |  |  |    |   |   |   |   |   |    |  |  |  |  |    |    |  |  |  |  |    |    |  |  |  |  |    |    |      |      |  |  |    |    |   |       |  |  |    |    |      |      |  |  |    |    |      |      |      |      |    |    |   |       |   |       |    |  |      |      |      |      |  |  |    |    |    |    |  |          |            |
| 16   |      |          |                         |       | 13 |   |  |  |   |   |   |  |   |   |  |  |  |  |  |    |   |   |   |   |   |    |  |  |  |  |    |    |  |  |  |  |    |    |  |  |  |  |    |    |      |      |  |  |    |    |   |       |  |  |    |    |      |      |  |  |    |    |      |      |      |      |    |    |   |       |   |       |    |  |      |      |      |      |  |  |    |    |    |    |  |          |            |
| 20   |      |          |                         |       | 17 |   |  |  |   |   |   |  |   |   |  |  |  |  |  |    |   |   |   |   |   |    |  |  |  |  |    |    |  |  |  |  |    |    |  |  |  |  |    |    |      |      |  |  |    |    |   |       |  |  |    |    |      |      |  |  |    |    |      |      |      |      |    |    |   |       |   |       |    |  |      |      |      |      |  |  |    |    |    |    |  |          |            |
| 24   |      |          |                         |       | 21 |   |  |  |   |   |   |  |   |   |  |  |  |  |  |    |   |   |   |   |   |    |  |  |  |  |    |    |  |  |  |  |    |    |  |  |  |  |    |    |      |      |  |  |    |    |   |       |  |  |    |    |      |      |  |  |    |    |      |      |      |      |    |    |   |       |   |       |    |  |      |      |      |      |  |  |    |    |    |    |  |          |            |
| 28   | (30) | (85)     |                         |       | 25 |   |  |  |   |   |   |  |   |   |  |  |  |  |  |    |   |   |   |   |   |    |  |  |  |  |    |    |  |  |  |  |    |    |  |  |  |  |    |    |      |      |  |  |    |    |   |       |  |  |    |    |      |      |  |  |    |    |      |      |      |      |    |    |   |       |   |       |    |  |      |      |      |      |  |  |    |    |    |    |  |          |            |
| 32   | J    | (87A)    |                         |       | 29 |   |  |  |   |   |   |  |   |   |  |  |  |  |  |    |   |   |   |   |   |    |  |  |  |  |    |    |  |  |  |  |    |    |  |  |  |  |    |    |      |      |  |  |    |    |   |       |  |  |    |    |      |      |  |  |    |    |      |      |      |      |    |    |   |       |   |       |    |  |      |      |      |      |  |  |    |    |    |    |  |          |            |
| 36   | (86) | (87)     |                         |       | 33 |   |  |  |   |   |   |  |   |   |  |  |  |  |  |    |   |   |   |   |   |    |  |  |  |  |    |    |  |  |  |  |    |    |  |  |  |  |    |    |      |      |  |  |    |    |   |       |  |  |    |    |      |      |  |  |    |    |      |      |      |      |    |    |   |       |   |       |    |  |      |      |      |      |  |  |    |    |    |    |  |          |            |
| 40   | (30) | (85)     | (30)                    | (85)  | 37 |   |  |  |   |   |   |  |   |   |  |  |  |  |  |    |   |   |   |   |   |    |  |  |  |  |    |    |  |  |  |  |    |    |  |  |  |  |    |    |      |      |  |  |    |    |   |       |  |  |    |    |      |      |  |  |    |    |      |      |      |      |    |    |   |       |   |       |    |  |      |      |      |      |  |  |    |    |    |    |  |          |            |
| 44   | L    | (87A)    | M                       | (87A) | 41 |   |  |  |   |   |   |  |   |   |  |  |  |  |  |    |   |   |   |   |   |    |  |  |  |  |    |    |  |  |  |  |    |    |  |  |  |  |    |    |      |      |  |  |    |    |   |       |  |  |    |    |      |      |  |  |    |    |      |      |      |      |    |    |   |       |   |       |    |  |      |      |      |      |  |  |    |    |    |    |  |          |            |
|  | (86) | (87)     | (86)                    | (87)  |    |   |  |  |   |   |   |  |   |   |  |  |  |  |  |    |   |   |   |   |   |    |  |  |  |  |    |    |  |  |  |  |    |    |  |  |  |  |    |    |      |      |  |  |    |    |   |       |  |  |    |    |      |      |  |  |    |    |      |      |      |      |    |    |   |       |   |       |    |  |      |      |      |      |  |  |    |    |    |    |  |          |            |
|  | 48   | 47       | 46                      | 45    |    |   |  |  |   |   |   |  |   |   |  |  |  |  |  |    |   |   |   |   |   |    |  |  |  |  |    |    |  |  |  |  |    |    |  |  |  |  |    |    |      |      |  |  |    |    |   |       |  |  |    |    |      |      |  |  |    |    |      |      |      |      |    |    |   |       |   |       |    |  |      |      |      |      |  |  |    |    |    |    |  |          |            |
|  |      | <b>B</b> | Lights 15 amp           |       |    |   |  |  |   |   |   |  |   |   |  |  |  |  |  |    |   |   |   |   |   |    |  |  |  |  |    |    |  |  |  |  |    |    |  |  |  |  |    |    |      |      |  |  |    |    |   |       |  |  |    |    |      |      |  |  |    |    |      |      |      |      |    |    |   |       |   |       |    |  |      |      |      |      |  |  |    |    |    |    |  |          |            |
|  |      | <b>C</b> | Water pump              |       |    |   |  |  |   |   |   |  |   |   |  |  |  |  |  |    |   |   |   |   |   |    |  |  |  |  |    |    |  |  |  |  |    |    |  |  |  |  |    |    |      |      |  |  |    |    |   |       |  |  |    |    |      |      |  |  |    |    |      |      |      |      |    |    |   |       |   |       |    |  |      |      |      |      |  |  |    |    |    |    |  |          |            |
|  |      | <b>E</b> | Oil cooler              |       |    |   |  |  |   |   |   |  |   |   |  |  |  |  |  |    |   |   |   |   |   |    |  |  |  |  |    |    |  |  |  |  |    |    |  |  |  |  |    |    |      |      |  |  |    |    |   |       |  |  |    |    |      |      |  |  |    |    |      |      |      |      |    |    |   |       |   |       |    |  |      |      |      |      |  |  |    |    |    |    |  |          |            |
|  |      | <b>F</b> | Power steer harness     |       |    |   |  |  |   |   |   |  |   |   |  |  |  |  |  |    |   |   |   |   |   |    |  |  |  |  |    |    |  |  |  |  |    |    |  |  |  |  |    |    |      |      |  |  |    |    |   |       |  |  |    |    |      |      |  |  |    |    |      |      |      |      |    |    |   |       |   |       |    |  |      |      |      |      |  |  |    |    |    |    |  |          |            |
|  |      | <b>G</b> | Spare 15                |       |    |   |  |  |   |   |   |  |   |   |  |  |  |  |  |    |   |   |   |   |   |    |  |  |  |  |    |    |  |  |  |  |    |    |  |  |  |  |    |    |      |      |  |  |    |    |   |       |  |  |    |    |      |      |  |  |    |    |      |      |      |      |    |    |   |       |   |       |    |  |      |      |      |      |  |  |    |    |    |    |  |          |            |
|  |      | <b>H</b> | Spare 5                 |       |    |   |  |  |   |   |   |  |   |   |  |  |  |  |  |    |   |   |   |   |   |    |  |  |  |  |    |    |  |  |  |  |    |    |  |  |  |  |    |    |      |      |  |  |    |    |   |       |  |  |    |    |      |      |  |  |    |    |      |      |      |      |    |    |   |       |   |       |    |  |      |      |      |      |  |  |    |    |    |    |  |          |            |
|  |      | <b>J</b> | Auxiliary relay         |       |    |   |  |  |   |   |   |  |   |   |  |  |  |  |  |    |   |   |   |   |   |    |  |  |  |  |    |    |  |  |  |  |    |    |  |  |  |  |    |    |      |      |  |  |    |    |   |       |  |  |    |    |      |      |  |  |    |    |      |      |      |      |    |    |   |       |   |       |    |  |      |      |      |      |  |  |    |    |    |    |  |          |            |
|  |      | <b>L</b> | Oil cooler relay        |       |    |   |  |  |   |   |   |  |   |   |  |  |  |  |  |    |   |   |   |   |   |    |  |  |  |  |    |    |  |  |  |  |    |    |  |  |  |  |    |    |      |      |  |  |    |    |   |       |  |  |    |    |      |      |  |  |    |    |      |      |      |      |    |    |   |       |   |       |    |  |      |      |      |      |  |  |    |    |    |    |  |          |            |
|  |      | <b>M</b> | Operator presence relay |       |    |   |  |  |   |   |   |  |   |   |  |  |  |  |  |    |   |   |   |   |   |    |  |  |  |  |    |    |  |  |  |  |    |    |  |  |  |  |    |    |      |      |  |  |    |    |   |       |  |  |    |    |      |      |  |  |    |    |      |      |      |      |    |    |   |       |   |       |    |  |      |      |      |      |  |  |    |    |    |    |  |          |            |

14.6 Electrical Schematic—CRT48-57K-PS

Note: The machine may or may not have Item 32 and the "Alt B" connection.

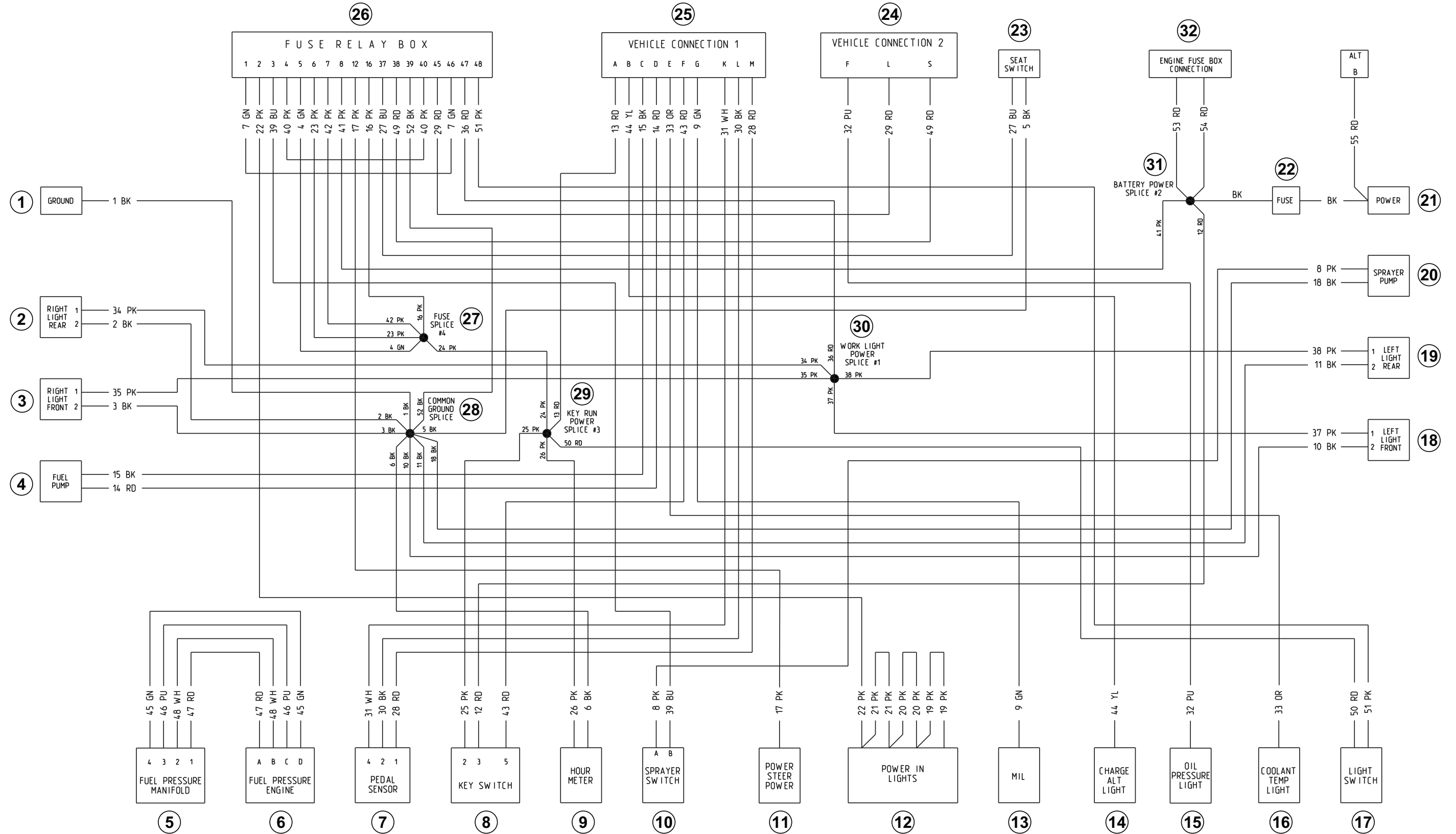

5200036154\_01

14.7 Electrical Schematic Components—CRT48-57K-PS

| Ref. | Description   | Ref. | Description                 |
|------|---|------|-----------------------------|
| 1    | Ground  | 17   | Light switch                |
| 2    | Light, right rear   | 18   | Light, left front           |
| 3    | Light, right front  | 19   | Light, left rear            |
| 4    | Fuel pump   | 20   | Sprayer pump                |
| 5    | Fuel pressure manifold                                    | 21   | Power from starter          |
| 6    | Fuel pressure engine                                      | 22   | 40A fuse                    |
| 7    | Pedal sensor  | 23   | Seat switch                 |
| 8    | Key switch  | 24   | Vehicle connection 2        |
| 9    | Hour meter  | 25   | Vehicle connection 1        |
| 10   | Sprayer switch  | 26   | Fuse / relay box            |
| 11   | Power steer power   | 27   | Splice #4, fuse             |
| 12   | Power in lights   | 28   | Splice, common ground       |
| 13   | Malfunction Indicator Light (MIL)<br>(Check engine light) | 29   | Splice #3, key run power    |
| 14   | Charge alternator   | 30   | Splice #1, work light power |
| 15   | Light, oil pressure                                       | 31   | Splice #2, battery power    |
| 16   | Coolant temperature                                       | 32   | Fuse box, engine            |

14.8 Fuse/Relay Box Layout

|  |      | Position | Description                |      |    |   |  |  |   |   |   |   |  |   |  |  |  |  |   |    |   |  |  |  |   |    |  |  |  |  |    |    |  |  |  |  |    |    |  |  |  |  |    |    |  |  |  |  |    |    |  |  |  |  |    |    |  |  |  |  |    |    |      |      |      |      |    |    |  |   |  |   |    |  |      |      |      |      |  |  |    |    |    |    |  |          |                      |
|--|------|----------|----------------------------|------|----|---|--|--|---|---|---|---|--|---|--|--|--|--|---|----|---|--|--|--|---|----|--|--|--|--|----|----|--|--|--|--|----|----|--|--|--|--|----|----|--|--|--|--|----|----|--|--|--|--|----|----|--|--|--|--|----|----|------|------|------|------|----|----|--|---|--|---|----|--|------|------|------|------|--|--|----|----|----|----|--|----------|----------------------|
| <table border="1" style="margin-left: auto; margin-right: auto;"> <tr> <td></td> <td>4</td> <td>3</td> <td>2</td> <td>1</td> <td></td> </tr> <tr> <td></td> <td>A</td> <td>B</td> <td>C</td> <td>D</td> <td></td> </tr> <tr> <td>8</td> <td></td> <td></td> <td></td> <td></td> <td>5</td> </tr> <tr> <td>12</td> <td>E</td> <td></td> <td></td> <td></td> <td>9</td> </tr> <tr> <td>16</td> <td></td> <td></td> <td></td> <td></td> <td>13</td> </tr> <tr> <td>20</td> <td></td> <td></td> <td></td> <td></td> <td>17</td> </tr> <tr> <td>24</td> <td></td> <td></td> <td></td> <td></td> <td>21</td> </tr> <tr> <td>28</td> <td></td> <td></td> <td></td> <td></td> <td>25</td> </tr> <tr> <td>32</td> <td></td> <td></td> <td></td> <td></td> <td>29</td> </tr> <tr> <td>36</td> <td></td> <td></td> <td></td> <td></td> <td>33</td> </tr> <tr> <td>40</td> <td>(30)</td> <td>(85)</td> <td>(30)</td> <td>(85)</td> <td>37</td> </tr> <tr> <td>44</td> <td></td> <td>G</td> <td></td> <td>F</td> <td>41</td> </tr> <tr> <td></td> <td>(86)</td> <td>(87)</td> <td>(86)</td> <td>(87)</td> <td></td> </tr> <tr> <td></td> <td>48</td> <td>47</td> <td>46</td> <td>45</td> <td></td> </tr> </table> <p style="text-align: center; margin-top: 5px;">wc_gr012980</p> |      |          | 4                          | 3    | 2  | 1 |  |  | A | B | C | D |  | 8 |  |  |  |  | 5 | 12 | E |  |  |  | 9 | 16 |  |  |  |  | 13 | 20 |  |  |  |  | 17 | 24 |  |  |  |  | 21 | 28 |  |  |  |  | 25 | 32 |  |  |  |  | 29 | 36 |  |  |  |  | 33 | 40 | (30) | (85) | (30) | (85) | 37 | 44 |  | G |  | F | 41 |  | (86) | (87) | (86) | (87) |  |  | 48 | 47 | 46 | 45 |  | <b>A</b> | Work lights 25A fuse |
|  | 4    | 3        | 2                          | 1    |    |   |  |  |   |   |   |   |  |   |  |  |  |  |   |    |   |  |  |  |   |    |  |  |  |  |    |    |  |  |  |  |    |    |  |  |  |  |    |    |  |  |  |  |    |    |  |  |  |  |    |    |  |  |  |  |    |    |      |      |      |      |    |    |  |   |  |   |    |  |      |      |      |      |  |  |    |    |    |    |  |          |                      |
|  | A    | B        | C                          | D    |    |   |  |  |   |   |   |   |  |   |  |  |  |  |   |    |   |  |  |  |   |    |  |  |  |  |    |    |  |  |  |  |    |    |  |  |  |  |    |    |  |  |  |  |    |    |  |  |  |  |    |    |  |  |  |  |    |    |      |      |      |      |    |    |  |   |  |   |    |  |      |      |      |      |  |  |    |    |    |    |  |          |                      |
| 8  |      |          |                            |      | 5  |   |  |  |   |   |   |   |  |   |  |  |  |  |   |    |   |  |  |  |   |    |  |  |  |  |    |    |  |  |  |  |    |    |  |  |  |  |    |    |  |  |  |  |    |    |  |  |  |  |    |    |  |  |  |  |    |    |      |      |      |      |    |    |  |   |  |   |    |  |      |      |      |      |  |  |    |    |    |    |  |          |                      |
| 12   | E    |          |                            |      | 9  |   |  |  |   |   |   |   |  |   |  |  |  |  |   |    |   |  |  |  |   |    |  |  |  |  |    |    |  |  |  |  |    |    |  |  |  |  |    |    |  |  |  |  |    |    |  |  |  |  |    |    |  |  |  |  |    |    |      |      |      |      |    |    |  |   |  |   |    |  |      |      |      |      |  |  |    |    |    |    |  |          |                      |
| 16   |      |          |                            |      | 13 |   |  |  |   |   |   |   |  |   |  |  |  |  |   |    |   |  |  |  |   |    |  |  |  |  |    |    |  |  |  |  |    |    |  |  |  |  |    |    |  |  |  |  |    |    |  |  |  |  |    |    |  |  |  |  |    |    |      |      |      |      |    |    |  |   |  |   |    |  |      |      |      |      |  |  |    |    |    |    |  |          |                      |
| 20   |      |          |                            |      | 17 |   |  |  |   |   |   |   |  |   |  |  |  |  |   |    |   |  |  |  |   |    |  |  |  |  |    |    |  |  |  |  |    |    |  |  |  |  |    |    |  |  |  |  |    |    |  |  |  |  |    |    |  |  |  |  |    |    |      |      |      |      |    |    |  |   |  |   |    |  |      |      |      |      |  |  |    |    |    |    |  |          |                      |
| 24   |      |          |                            |      | 21 |   |  |  |   |   |   |   |  |   |  |  |  |  |   |    |   |  |  |  |   |    |  |  |  |  |    |    |  |  |  |  |    |    |  |  |  |  |    |    |  |  |  |  |    |    |  |  |  |  |    |    |  |  |  |  |    |    |      |      |      |      |    |    |  |   |  |   |    |  |      |      |      |      |  |  |    |    |    |    |  |          |                      |
| 28   |      |          |                            |      | 25 |   |  |  |   |   |   |   |  |   |  |  |  |  |   |    |   |  |  |  |   |    |  |  |  |  |    |    |  |  |  |  |    |    |  |  |  |  |    |    |  |  |  |  |    |    |  |  |  |  |    |    |  |  |  |  |    |    |      |      |      |      |    |    |  |   |  |   |    |  |      |      |      |      |  |  |    |    |    |    |  |          |                      |
| 32   |      |          |                            |      | 29 |   |  |  |   |   |   |   |  |   |  |  |  |  |   |    |   |  |  |  |   |    |  |  |  |  |    |    |  |  |  |  |    |    |  |  |  |  |    |    |  |  |  |  |    |    |  |  |  |  |    |    |  |  |  |  |    |    |      |      |      |      |    |    |  |   |  |   |    |  |      |      |      |      |  |  |    |    |    |    |  |          |                      |
| 36   |      |          |                            |      | 33 |   |  |  |   |   |   |   |  |   |  |  |  |  |   |    |   |  |  |  |   |    |  |  |  |  |    |    |  |  |  |  |    |    |  |  |  |  |    |    |  |  |  |  |    |    |  |  |  |  |    |    |  |  |  |  |    |    |      |      |      |      |    |    |  |   |  |   |    |  |      |      |      |      |  |  |    |    |    |    |  |          |                      |
| 40   | (30) | (85)     | (30)                       | (85) | 37 |   |  |  |   |   |   |   |  |   |  |  |  |  |   |    |   |  |  |  |   |    |  |  |  |  |    |    |  |  |  |  |    |    |  |  |  |  |    |    |  |  |  |  |    |    |  |  |  |  |    |    |  |  |  |  |    |    |      |      |      |      |    |    |  |   |  |   |    |  |      |      |      |      |  |  |    |    |    |    |  |          |                      |
| 44   |      | G        |                            | F    | 41 |   |  |  |   |   |   |   |  |   |  |  |  |  |   |    |   |  |  |  |   |    |  |  |  |  |    |    |  |  |  |  |    |    |  |  |  |  |    |    |  |  |  |  |    |    |  |  |  |  |    |    |  |  |  |  |    |    |      |      |      |      |    |    |  |   |  |   |    |  |      |      |      |      |  |  |    |    |    |    |  |          |                      |
|  | (86) | (87)     | (86)                       | (87) |    |   |  |  |   |   |   |   |  |   |  |  |  |  |   |    |   |  |  |  |   |    |  |  |  |  |    |    |  |  |  |  |    |    |  |  |  |  |    |    |  |  |  |  |    |    |  |  |  |  |    |    |  |  |  |  |    |    |      |      |      |      |    |    |  |   |  |   |    |  |      |      |      |      |  |  |    |    |    |    |  |          |                      |
|  | 48   | 47       | 46                         | 45   |    |   |  |  |   |   |   |   |  |   |  |  |  |  |   |    |   |  |  |  |   |    |  |  |  |  |    |    |  |  |  |  |    |    |  |  |  |  |    |    |  |  |  |  |    |    |  |  |  |  |    |    |  |  |  |  |    |    |      |      |      |      |    |    |  |   |  |   |    |  |      |      |      |      |  |  |    |    |    |    |  |          |                      |
|  |      | <b>B</b> | Water pump 5A fuse         |      |    |   |  |  |   |   |   |   |  |   |  |  |  |  |   |    |   |  |  |  |   |    |  |  |  |  |    |    |  |  |  |  |    |    |  |  |  |  |    |    |  |  |  |  |    |    |  |  |  |  |    |    |  |  |  |  |    |    |      |      |      |      |    |    |  |   |  |   |    |  |      |      |      |      |  |  |    |    |    |    |  |          |                      |
|  |      | <b>C</b> | Light cluster 5A fuse      |      |    |   |  |  |   |   |   |   |  |   |  |  |  |  |   |    |   |  |  |  |   |    |  |  |  |  |    |    |  |  |  |  |    |    |  |  |  |  |    |    |  |  |  |  |    |    |  |  |  |  |    |    |  |  |  |  |    |    |      |      |      |      |    |    |  |   |  |   |    |  |      |      |      |      |  |  |    |    |    |    |  |          |                      |
|  |      | <b>D</b> | Operator presence 15A fuse |      |    |   |  |  |   |   |   |   |  |   |  |  |  |  |   |    |   |  |  |  |   |    |  |  |  |  |    |    |  |  |  |  |    |    |  |  |  |  |    |    |  |  |  |  |    |    |  |  |  |  |    |    |  |  |  |  |    |    |      |      |      |      |    |    |  |   |  |   |    |  |      |      |      |      |  |  |    |    |    |    |  |          |                      |
|  |      | <b>E</b> | Power steer power 10A fuse |      |    |   |  |  |   |   |   |   |  |   |  |  |  |  |   |    |   |  |  |  |   |    |  |  |  |  |    |    |  |  |  |  |    |    |  |  |  |  |    |    |  |  |  |  |    |    |  |  |  |  |    |    |  |  |  |  |    |    |      |      |      |      |    |    |  |   |  |   |    |  |      |      |      |      |  |  |    |    |    |    |  |          |                      |
|  |      | <b>F</b> | Operator presence relay    |      |    |   |  |  |   |   |   |   |  |   |  |  |  |  |   |    |   |  |  |  |   |    |  |  |  |  |    |    |  |  |  |  |    |    |  |  |  |  |    |    |  |  |  |  |    |    |  |  |  |  |    |    |  |  |  |  |    |    |      |      |      |      |    |    |  |   |  |   |    |  |      |      |      |      |  |  |    |    |    |    |  |          |                      |
|  |      | <b>G</b> | Work light relay           |      |    |   |  |  |   |   |   |   |  |   |  |  |  |  |   |    |   |  |  |  |   |    |  |  |  |  |    |    |  |  |  |  |    |    |  |  |  |  |    |    |  |  |  |  |    |    |  |  |  |  |    |    |  |  |  |  |    |    |      |      |      |      |    |    |  |   |  |   |    |  |      |      |      |      |  |  |    |    |    |    |  |          |                      |

| Wire Colors |       |            |        |           |        |           |          |
|-------------|-------|------------|--------|-----------|--------|-----------|----------|
| <b>BK</b>   | Black | <b>RD</b>  | Red    | <b>YL</b> | Yellow | <b>OR</b> | Orange   |
| <b>GN</b>   | Green | <b>TN</b>  | Tan    | <b>BR</b> | Brown  | <b>PU</b> | Purple   |
| <b>BU</b>   | Blue  | <b>VIO</b> | Violet | <b>CL</b> | Clear  | <b>SH</b> | Shield   |
| <b>PK</b>   | Pink  | <b>WH</b>  | White  | <b>GY</b> | Gray   | <b>LB</b> | Lt. blue |

14.9 Electrical Schematic—Power Steer Circuit

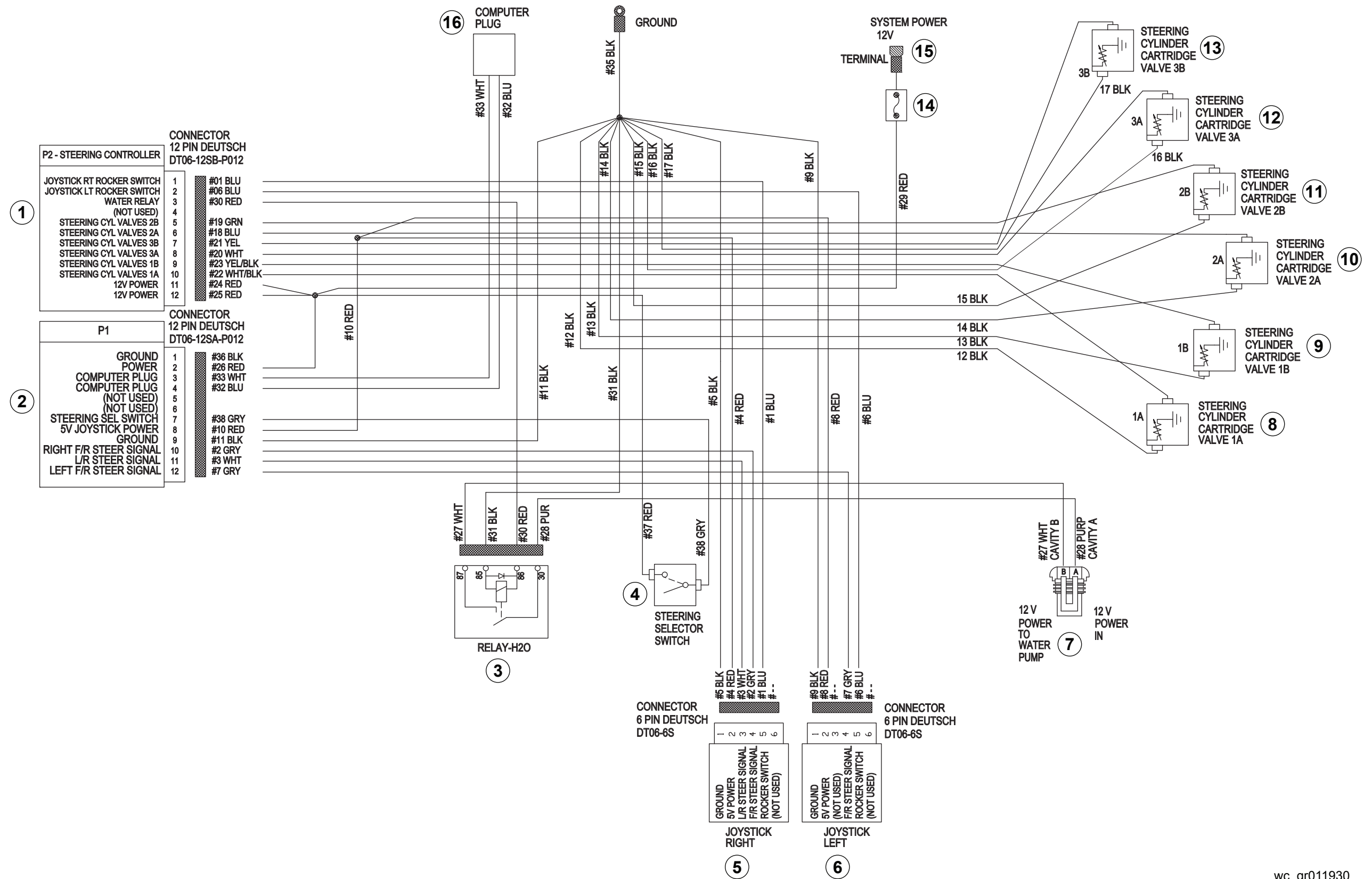

wc\_gr011930



14.10 Electrical Schematic Components—Power Steer Circuit

| Ref. | Description                          | Ref. | Description                           |
|------|--------------------------------------|------|---------------------------------------|
| 1    | Connector (black)                    | 9    | Steering cylinder cartridge valve 1B  |
| 2    | Connector (gray)                     | 10   | Steering cylinder cartridge valve 2AB |
| 3    | Relay—H20                            | 11   | Steering cylinder cartridge valve 2B  |
| 4    | Steering selector switch             | 12   | Steering cylinder cartridge valve 3A  |
| 5    | Joystick right                       | 13   | Steering cylinder cartridge valve 3B  |
| 6    | Joystick left                        | 14   | Fuse 10A                              |
| 7    | To water pump                        | 15   | System power 12V                      |
| 8    | Steering cylinder cartridge valve 1A | 16   | Computer plug to laptop               |

| P2 - Steering Controller (black) |
|----------------------------------|
| Joystick RT rocker switch        |
| Joystick LT rocker switch        |
| Water relay                      |
| (Not used)                       |
| Steering cylinder valves 2B      |
| Steering cylinder valves 2A      |
| Steering cylinder valves 3B      |
| Steering cylinder valves 3A      |
| Steering cylinder valves 1B      |
| Steering cylinder valves 1A      |
| 12V power                        |
| 12V power                        |

| P1 - Steering Controller (gray) |
|---------------------------------|
| Ground                          |
| Power                           |
| Computer plug                   |
| Computer plug                   |
| (Not used)                      |
| (Not used)                      |
| Steering selector switch        |
| 5V joystick power               |
| Ground                          |
| Right F/R steering signal       |
| L/R steering signal             |
| Left F/R steering signal        |

| Joystick right      |
|---------------------|
| Ground              |
| 5V power            |
| L/R steering signal |
| F/R steering signal |
| Rocker switch       |
| (Not used)          |

| Joystick left       |
|---------------------|
| Ground              |
| 5V power            |
| (Not used)          |
| F/R steering signal |
| Rocker switch       |
| (Not used)          |

| Wire Colors |       |     |        |     |        |     |        |
|-------------|-------|-----|--------|-----|--------|-----|--------|
| BLK         | Black | RED | Red    | WHT | White  | ORG | Orange |
| GRN         | Green | TAN | Tan    | YEL | Yellow | BRN | Brown  |
| BLU         | Blue  | VIO | Violet | GRY | Gray   | PNK | Pink   |

14.11 Hydraulic Schematic

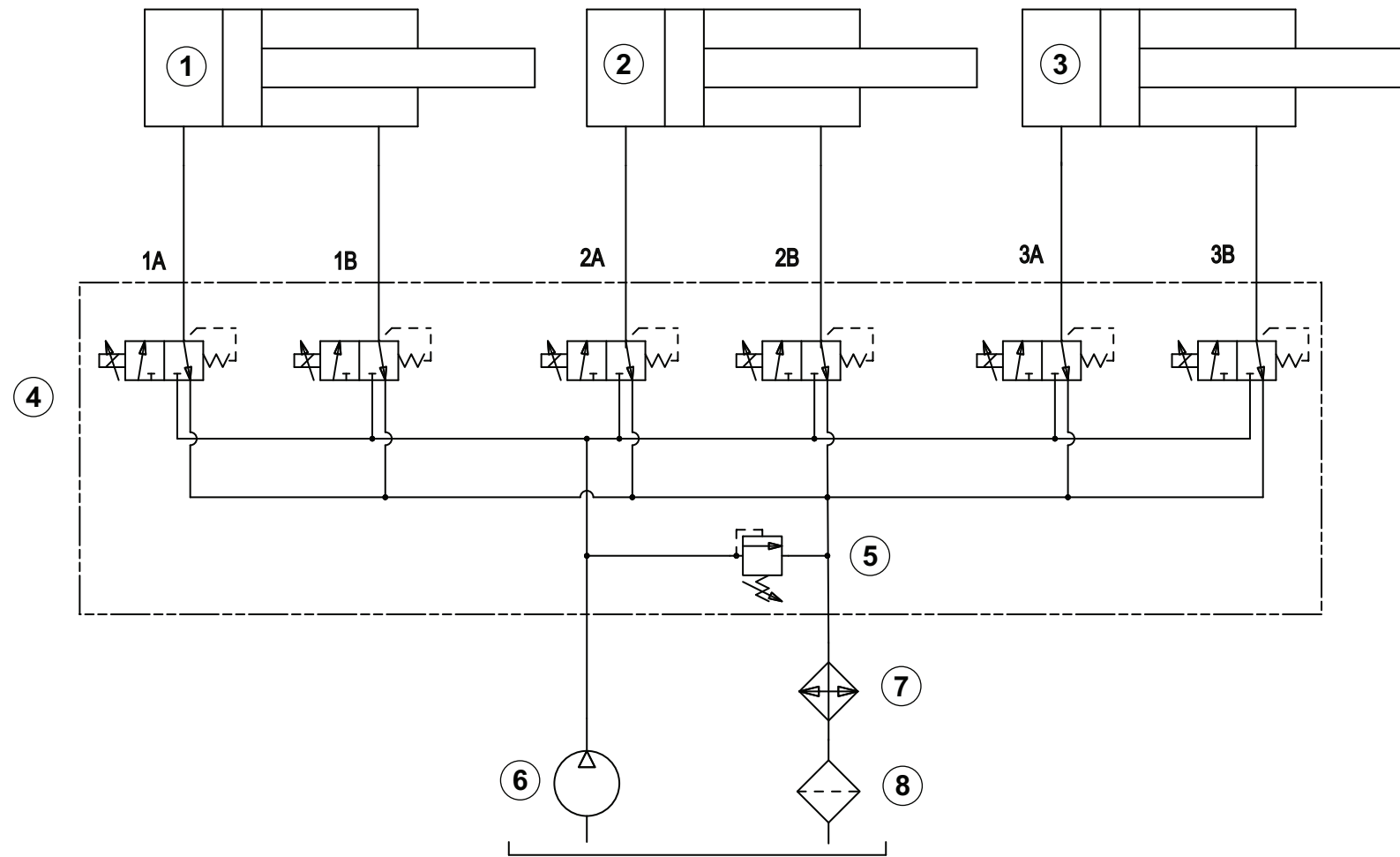

wc\_gr011932

14.12 Hydraulic Schematic Components

| Ref. | Description                          | Ref. | Description                |
|------|--------------------------------------|------|----------------------------|
| 1    | Left F/R steering cylinder           | 5    | Relief valve, 950 psi ± 50 |
| 2    | Right F/R steering cylinder          | 6    | Gear pump                  |
| 3    | L/R steering cylinder                | 7    | Hydraulic fluid cooler     |
| 4    | Manifold                             | 8    | Oil filter                 |
|      | Steering cylinder cartridge valve 1A | —    |                            |
|      | Steering cylinder cartridge valve 1B | —    |                            |
|      | Steering cylinder cartridge valve 2A | —    |                            |
|      | Steering cylinder cartridge valve 2B | —    |                            |
|      | Steering cylinder cartridge valve 3A | —    |                            |
|      | Steering cylinder cartridge valve 3B | —    |                            |

**Important:** For spare parts information, please see your Wacker Neuson Dealer, or visit the Wacker Neuson website at <http://www.wackerneuson.com/>.

**Wichtig!** Informationen über Ersatzteile erhalten Sie von Ihrem Wacker Neuson Händler oder besuchen Sie die Wacker Neuson Website unter <http://www.wackerneuson.com/>.

**Important :** Pour des informations sur les pièces détachées, merci de consulter votre distributeur Wacker Neuson, ou de visiter le site Internet de Wacker Neuson sur <http://www.wackerneuson.com/>.

**Importante :** Para saber más sobre las piezas de repuesto, póngase en contacto con su distribuidor de Wacker Neuson o acceda al sitio web de Wacker Neuson en <http://www.wackerneuson.com/>.

**Importante :** Per informazioni sui pezzi di ricambio, contattare il rivenditore Wacker Neuson o visitare il sito di Wacker Neuson all'indirizzo [www.wackerneuson.com](http://www.wackerneuson.com/).

**Viktigt :** För information om reservdelar, kontakta din Wacker Neuson-leverantör eller besök Wacker Neusons webbplats på <http://www.wackerneuson.com/>.

**Tärkeää :** Pyydä varaosatietoja Wacker Neusonin jälleenmyyjältä tai vieraile Wacker Neusonin web-sivustolla osoitteessa <http://www.wackerneuson.com/>

**Viktig :** For informasjon om reservedeler, vennligst kontakt din Wacker Neuson-forhandler, eller besøk Wacker Neusons nettside på <http://www.wackerneuson.com/>.

**Viktigt :** Hvis du ønsker oplysninger om reservedele, bedes du kontakte din Wacker Neuson forhandler eller besøg Wacker Neuson websiden på <http://www.wackerneuson.com/>.

**Belangrijk!** Neem contact op met uw Wacker Neuson dealer of bezoek de website van Wacker Neuson op <http://www.wackerneuson.com/> voor meer informatie over reserveonderdelen.

**Importante :** Para obter informações sobre as peças sobresselentes, consulte o seu fornecedor da Wacker Neuson ou acesse ao site Web da Wacker Neuson em [http://www.wackerneuson.com](http://www.wackerneuson.com/)

**Ważne :** W celu uzyskania informacji na temat części zamiennych skontaktuj się z przedstawicielem firmy Wacker Neuson lub skorzystaj z witryny internetowej <http://www.wackerneuson.com/>.

**Důležitě upozornění!** Pro informace o náhradních dílech, prosím, kontaktujte svého Wacker Neuson dealera, nebo navštivte webové stránky <http://www.wackerneuson.com/>.

**FONTOS:** A pótalkatrészekre vonatkozó információkért kérjük, forduljon Wacker Neuson kereskedőjéhez vagy látogasson el a Wacker Neuson weboldalára a következő címen: <http://www.wackerneuson.com/>.

**Важно!** Для ознакомления с информацией о запасных частях, пожалуйста, обратитесь к местному торговому представителю компании Wacker Neuson или посетите веб-сайт <http://www.wackerneuson.com/>.

**Σημαντικό :** Για πληροφορίες σχετικά με τα ανταλλακτικά, μιλήστε με τον αντιπρόσωπό σας της Wacker Neuson, ή επισκεφθείτε τον ιστότοπο <http://www.wackerneuson.com/>.

**Važno :** Za rezervne dijelove obratite se svom Wacker Neuson prodavaču ili posjetite mrežne stranice tvrtke Wacker Neuson: <http://www.wackerneuson.com/>.

**Önemli :** Yedek parça bilgileri için Wacker Neuson Bayinize bakın veya Wacker Neuson web sitesini ziyaret edin. <http://www.wackerneuson.com/>

**重要** 交換部品の情報については、ワッカーノイソンディーラーにお問い合わせ頂くか、ワッカーノイソンウェブサイト <http://www.wackerneuson.com/> をご覧ください。

**重要** 有关备件信息，请咨询您的威克诺森经销商或访问威克诺森网站：  
<http://www.wackerneuson.com/>。

**Important :** Pentru informații referitoare la piesele de schimb, vă rugăm să vă adresați distribuitorului Wacker Neuson sau să vizitați site-ul web Wacker Neuson la adresa <http://www.wackerneuson.com/>.

**Важно :** За информация относно резервни части, моля, обърнете се към местния дилър на Wacker Neuson или посетете уебсайта на Wacker Neuson на адрес <http://www.wackerneuson.com/>.

---

Wacker Neuson Produktion GmbH & Co. KG, Preußenstraße 41, D-80809 München,

Tel.: +49-(0)89-3 54 02-0 Fax: +49 - (0)89-3 54 02-390

Wacker Neuson Production Americas LLC, N92W15000 Anthony Ave., Menomonee Falls, WI. 53051

Tel.: (262) 255-0500 Fax: (262) 255-0550 Tel.: (800) 770-0957

Wacker Neuson Limited - Room 1701-03 & 1717-20, 17/F, Tower 1, Grand Century Place, 193 Prince Edward Road West, Mongkok, Kowloon, Hongkong. Tel: (852) 3605 5360, Fax: (852) 2758 0032

**Copyright notice**

© Copyright 2019 by Wacker Neuson Production Americas LLC

All rights, including copying and distribution rights, are reserved.

This publication may be photocopied by the original purchaser of the machine. Any other type of reproduction is prohibited without express written permission from Wacker Neuson Production Americas LLC.

Any type of reproduction or distribution not authorized by Wacker Neuson Production Americas LLC represents an infringement of valid copyrights. Violators will be prosecuted.

---

**Trademarks**

All trademarks referenced in this manual are the property of their respective owners.

---

**Manufacturer**

Wacker Neuson Production Americas LLC

N92W15000 Anthony Avenue

Menomonee Falls, WI 53051 U.S.A.

Tel: (262) 255-0500 · Fax: (262) 255-0550 · Tel: (800) 770-0957

[www.wackerneuson.com](http://www.wackerneuson.com)

---

**Original instructions**

This Operator's Manual presents the original instructions. The original language of this Operator's Manual is American English.

---