



# SPARE PARTS LIST

## TROWELS

BG 375 F QP TP US, 967856401, 2020-06

**A** BG 375 F QP TP US  
BLADE ASSY & PROTECTIVE CAGE

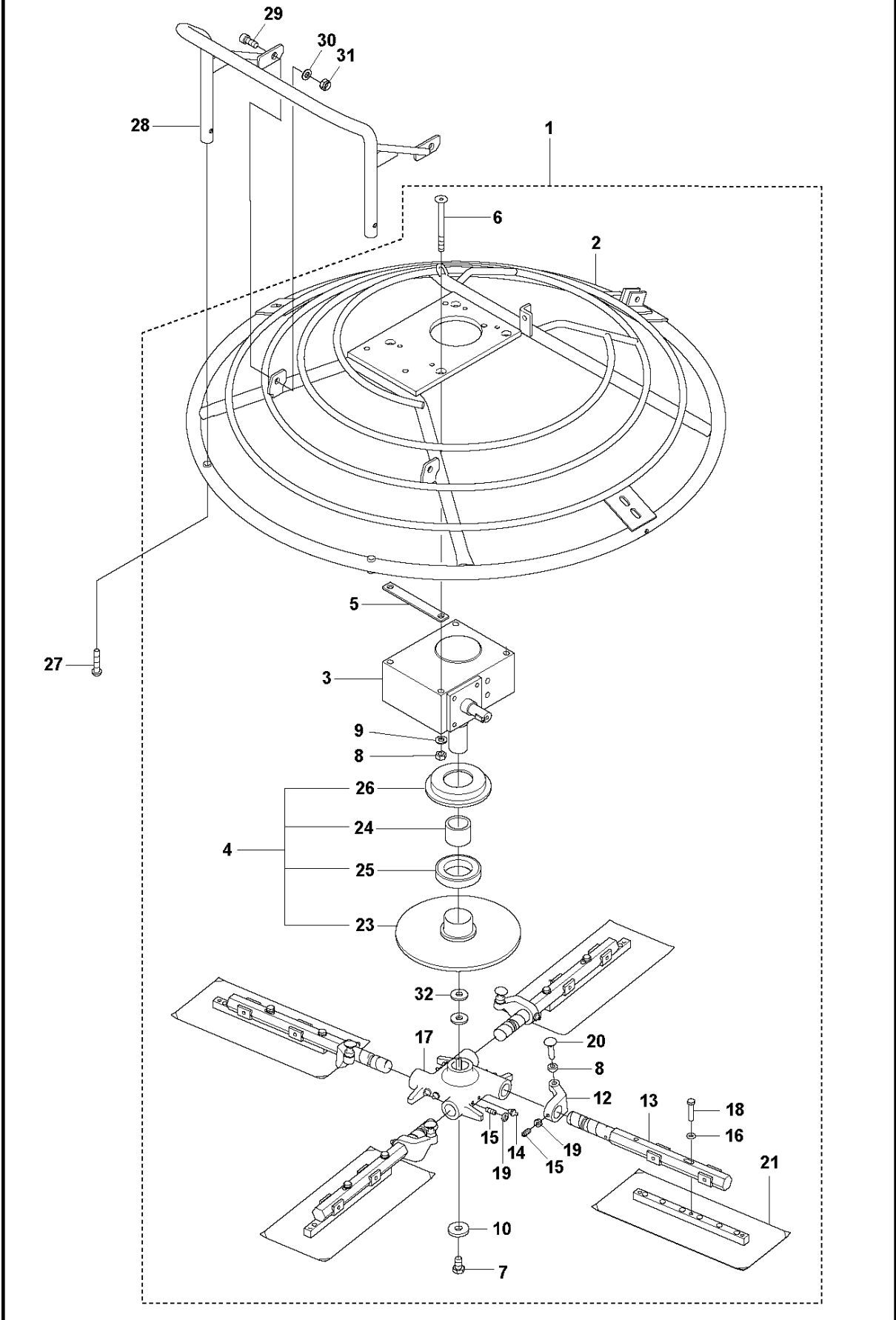

Ref	Part No	Description	Remark	QTY KIT	
1	595 29 82-01	UNIT		1	
2	595 29 81-01	CHASSIS		1	1
3	594 22 66-01	GEARBOX		1	1
4	595 13 66-01	PLATE		1	1
5	595 44 37-01	PLATE		1	1
6	594 28 79-01	SOCKET	M10x110 DIN7991-10.9 ZnB	4	1
7	594 11 90-01	BOLT	M12x30 DIN 933-8.8 zn	1	1
8	595 02 94-01	NUT	M10 DIN 934-8 Zn	8	1
9	595 11 33-01	WASHER	M10 ISO7089 A2K	4	1
10	594 12 40-01	WASHER	13x36x6 fzb	1	1
12	594 24 60-01	ARM		4	1
13	594 63 97-01	AXLE		4	1
14	594 12 68-01	LUBRICATION NIPPLE		4	1
15	594 28 60-01	SCREW	M8 x20 ISO 4028	8	1
16	595 03 66-01	WASHER	M8 ISO7089 A2K	8	1
17	594 24 03-01	HUB		1	1
18	595 03 35-01	SCREW	M8x40 ISO4014 8.8 A2K	8	1
19	595 35 17-01	NUT	M8 DIN 439 b zn	8	1
20	595 35 08-01	BOLT	M10x40 DIN 603-8.8 ZnB	4	1
21	594 71 11-01	BLADE KIT	Finish blades, bolt-on, set of 4 pcs.	1	1
23	594 24 17-01	PRESSURE PLATE		1	1, 4
24	594 22 68-01	BEARING		1	1, 4
25	595 03 81-01	BEARING		1	1, 4
26	594 24 86-01	BEARING PLATE		1	1, 4
27	595 21 24-01	SOCKET	M10x40 ISO7380 10.9 Zn	2	
28	595 29 78-01	HANDLE		1	
29	595 11 13-01	SCREW	M10x25 8.8 A3K ISO4762	2	
30	595 11 33-01	WASHER	M10 ISO7089 A2K	2	
31	595 18 34-01	NUT	M10 DIN985	2	
32	595 35 68-01	WASHER	32.7x45x2.5	2	

**B** BG 375 F QP TP US  
LIFTING BEAM

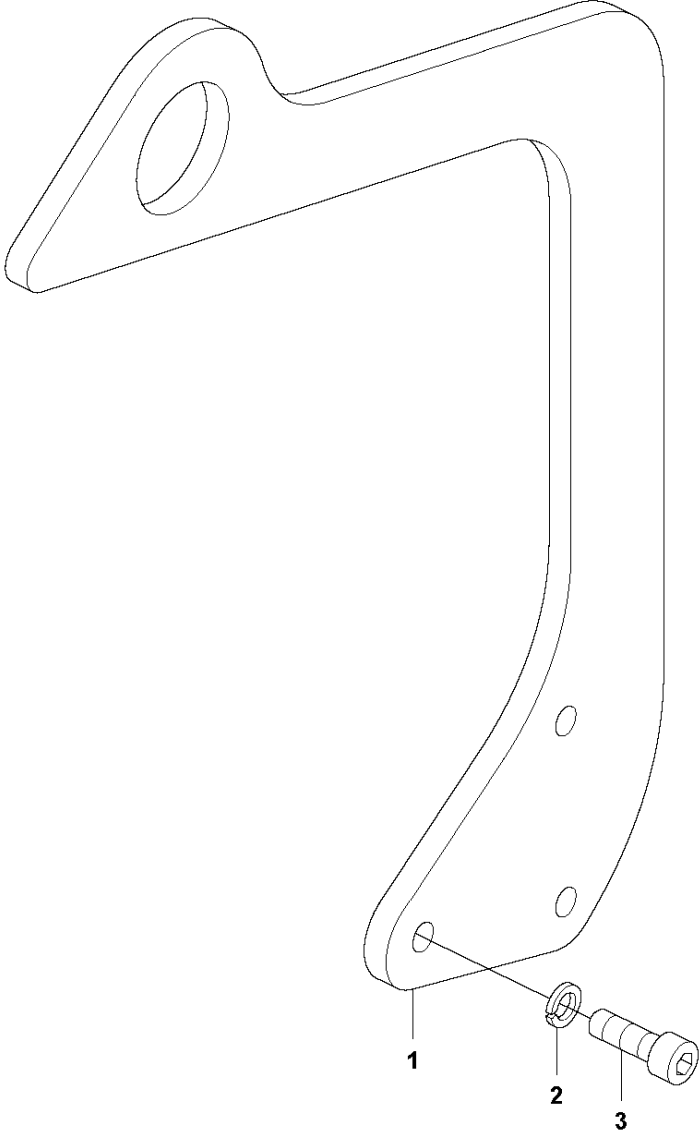

## LIFTING BEAM

BG 375 F QP TP US, 967856401, 2020-06

Ref	Part No	Description	Remark	QTY KIT
1	595 29 79-01	HANDLE		1
2	594 12 07-01	SCREW	M10x30 8.8 DIN912 FZB	3
3	595 11 38-01	WASHER	M10 DIN127B A2K	3

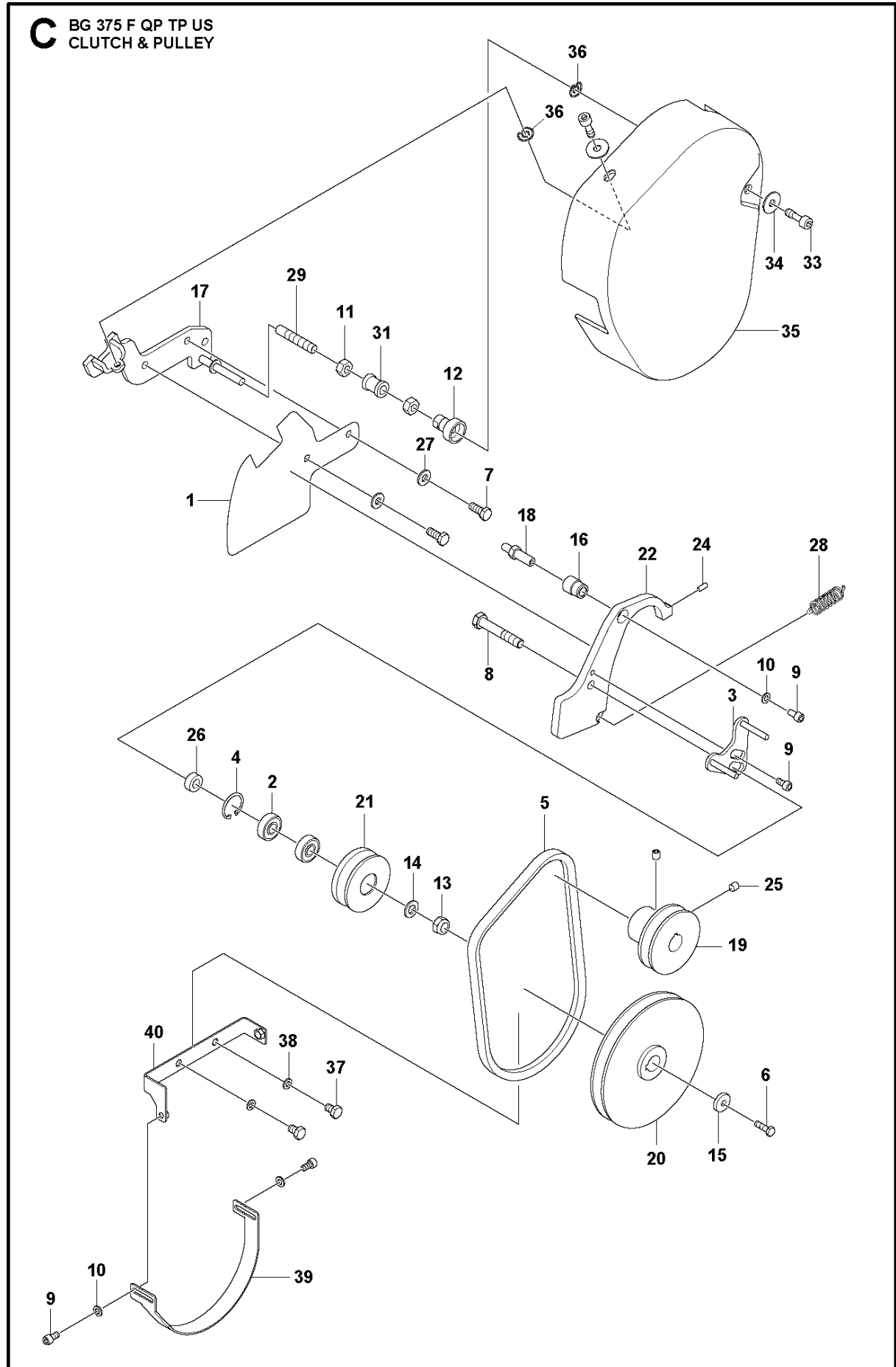

## CLUTCH &amp; PULLEY

BG 375 F QP TP US, 967856401, 2020-06

Ref	Part No	Description	Remark	QTY	KIT
1	594 86 55-01	BACKPLATE		1	
2	594 53 13-01	BALL BEARING	SKF 6002-2RS1	2	30
3	599 14 85-01	PLATE		1	30
4	595 03 73-01	RING	D 30 DIN472	1	30
5	599 13 39-01	BELT		1	30
6	595 10 98-01	SCREW	M06x020H ISO4017 8.8 A2K	1	
7	594 11 79-01	SCREW	M8x20 DIN 933 8.8 zn	2	
8	595 34 49-01	BOLT	M10x60 ISO4017 8.8 A3K	1	30
9	595 34 79-01	SOCKET	M6x12 ISO4762 8.8 A2K	4	30
10	595 03 65-01	WASHER	M6 ISO7089 A2K 200HV	3	30
11	595 02 94-01	NUT	M10 DIN 934-8 Zn	2	
12	594 86 56-01	HOLDER		1	
13	595 18 34-01	NUT	M10 DIN985	1	30
14	595 11 33-01	WASHER	M10 ISO7089 A2K	2	30
15	595 11 92-01	WASHER	6.4x22x4	1	
16	599149201	TBD		1	
17	594 86 54-01	PLATE		1	
18	599149101	TBD		1	
19	594 64 20-01	PULLEY		1	
20	594 24 16-01	PULLEY		1	
21	594 86 45-01	PULLEY		1	30
22	594 86 57-01	SPROCKET		1	30
23	599288701	TBD		1	30
24	594 28 62-01	SCREW	M5x12 45H ISO4028	1	30
25	595 34 67-01	SCREW	M8x8 ISO 4029 45H ZnB	2	
26	594 15 96-01	WASHER	10.5/20X8	1	30
27	595 11 36-01	WASHER	M8 DIN 6796 ZnB	2	
28	594 86 78-01	SPRING		1	
29	595 21 15-01	STUD	M10x55 DIN 976-8.8 ZnB	1	
30	599 14 89-01	RETRO FIT KIT	Retro-fit kit	1	
31	595 21 10-01	TUBE		1	
32	599 24 36-01	DECAL		1	30
33	594 64 25-01	SCREW		2	
34	594 12 37-01	WASHER	M8 DIN9021 (8.4x25x2)FZB	2	
35	594 95 88-01	COVER		1	
36	594 65 02-01	LOCKING SPRING		2	
37	596 88 97-07	SCREW	M8x12 ISO4017 8.8 A2K	2	30
38	595 03 66-01	WASHER	M8 ISO7089 A2K 200HV	2	30
39	599 14 86-01	PROTECTION RING		1	30
40	599 14 87-01	PLATE		1	30

**D** BG 375 F QP TP US  
ENGINE

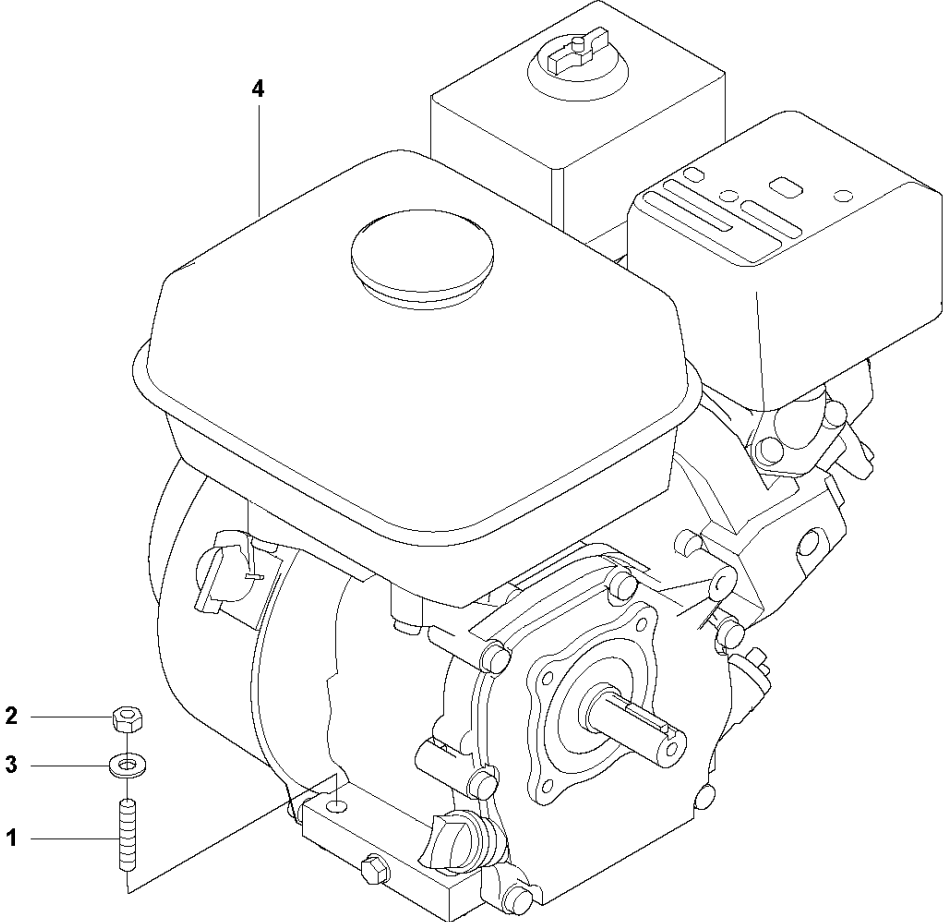



## ENGINE

BG 375 F QP TP US, 967856401, 2020-06

Ref	Part No	Description	Remark	QTY KIT
1	595 11 20-01	BOLT		4
2	595 03 57-01	NUT	M8 DIN 934-8 zn	4
3	595 11 36-01	WASHER	M8 DIN 6796 ZnB	4
4	594 16 11-01	ENGINE	Honda GX160UT2 SXS4 SD NH1	1

**E** BG 375 F QP TP US  
HANDLE

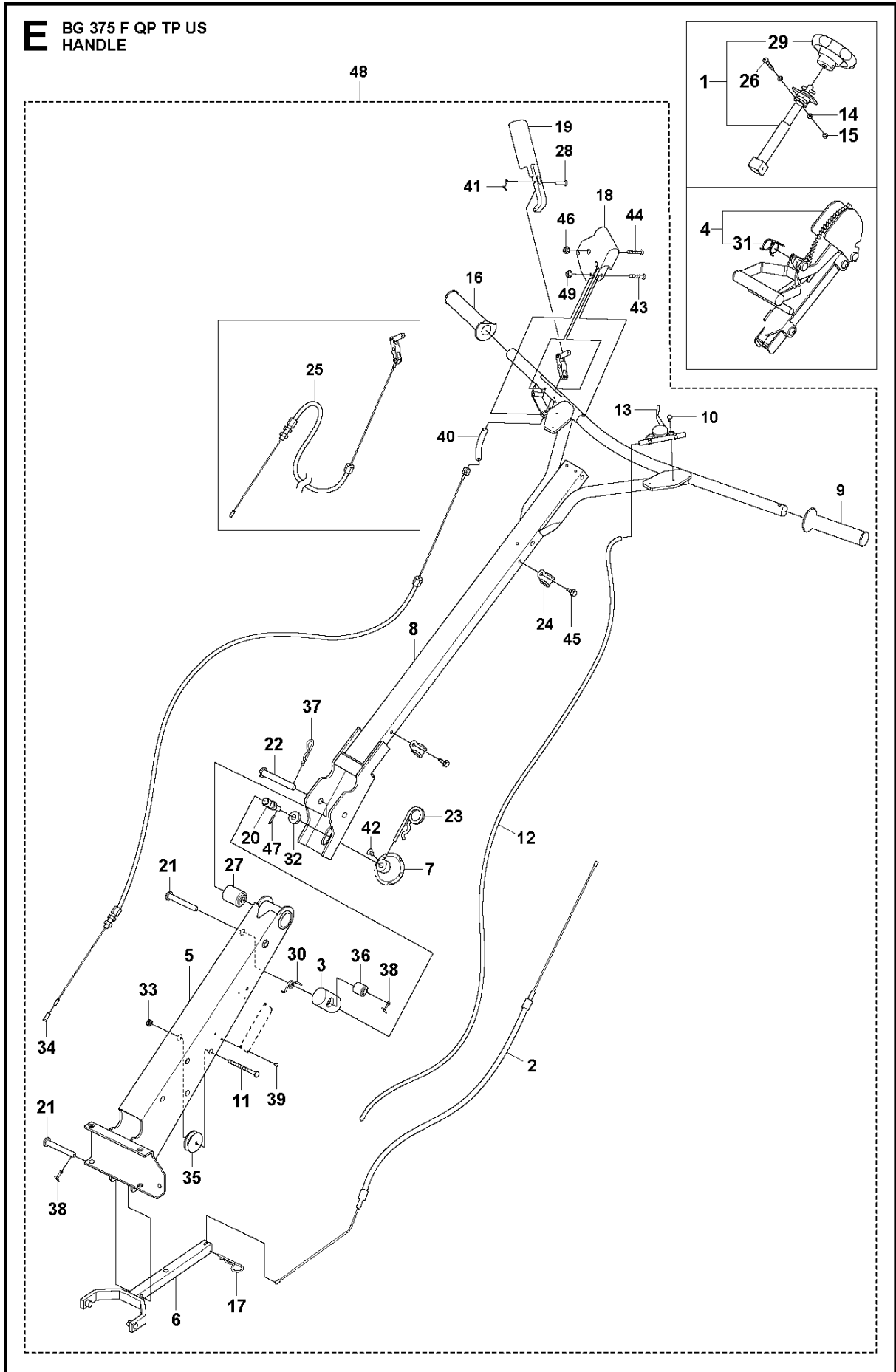

Ref	Part No	Description	Remark	QTY	KIT
1	594 19 84-01	BLADE	Blade Adjuster, Complete	1	
2	594 63 90-01	WIRE	Blade adjuster cable	1	48
3	594 86 59-01	BUSHING		1	48
4	595 52 62-01	UNIT	Blade Adjuster, Quick pitch, Complete	1	
5	595 29 80-01	CONSOLE		1	48
6	594 24 38-01	FORK		1	48
7	594 64 14-01	HANDLE		1	48
8	595 29 86-01	HANDLE		1	48
9	594 22 33-01	HANDLE		1	48
10	595 21 16-01	SCREW	M5x16 ISO7380 10.9 ZnB	2	48
11	594 11 78-01	BOLT	M6x70 8.8 ISO4014 A2K	1	48
12	594 63 92-01	THROTTLE	Throttle cable	1	48
13	594 22 41-01	CONTROL LEVER		1	48
14	594 12 38-01	PLANE WASHER	M5 ISO7089 200HV A2K	6	
15	595 11 24-01	NUT	M5 DIN985-8 Zn	3	
16	594 86 62-01	HANDLE		1	48
17	594 11 75-01	SPRING PIN		1	48
18	595 27 93-01	LEVER		1	48
19	595 27 58-01	COVER		1	48
20	594 64 12-01	STUD		1	48
21	595 10 96-01	PIN	10x70 ISO2341 type B ZnB	2	48
22	595 21 07-01	CLEVIS PIN	12x80 ISO2341 type B ZnB	1	48
23	594 86 60-01	CLIP	D4 DIN11024 Zn	1	48
24	595 11 46-01	PIPE CLAMP		2	48
25	597 92 33-02	CABLE ASSY	Clutch cable, complete	1	48
26	595 21 17-01	SCREW	M5x40 ISO7380 10.9 Zn	3	48
27	594 86 37-01	SLEEVE		1	48
28	594 64 13-01	CLEVIS PIN	4x14 ISO 2341 Zn	1	48
29	594 24 57-01	KNOB		1	1
30	594 63 88-01	SPRING		1	48
31	595 49 99-01	SPRING		1	4
32	594 86 61-01	SUPPORT		2	48
33	595 18 71-01	LOCK NUT	M6 DIN 985-8 Zn	1	48
34	594 25 77-01	TERMINAL		1	48
35	594 86 36-01	PULLEY		1	48
36	594 86 38-01	SLEEVE		1	48
37	594 11 74-01	CLIP		1	48
38	594 11 73-01	SPLIT PIN	3.2x20 ISO1234 A2K	2	48
39	595 34 40-01	RIVET	POP RIVET D2,4X8,6	4	48
40	594 86 52-01	JOINT		1	48
41	595 03 30-01	PIN	1x8 ISO1234	1	48
42	594 75 06-01	SCREW	M5x8 DIN 7991	1	48
43	595 52 63-01	SCREW	M5x30 ISO 7380 Zn	2	48
44	595 50 05-01	SCREW	M4x30 ISO 7380 Zn	2	48
45	595 35 58-01	SCREW	4.8x16 DIN7504K Zn	2	48
46	595 35 19-01	LOCK NUT	M4 DIN985-8 Zn	2	48
47	595 10 94-01	PIN	4x24 ISO8752	1	48
48	595 29 83-01	HANDLE	Handle, complete	1	
49	595 11 24-01	NUT	M5 DIN985-8 Zn	2	48

**F** BG 375 F QP TP US  
DECALS

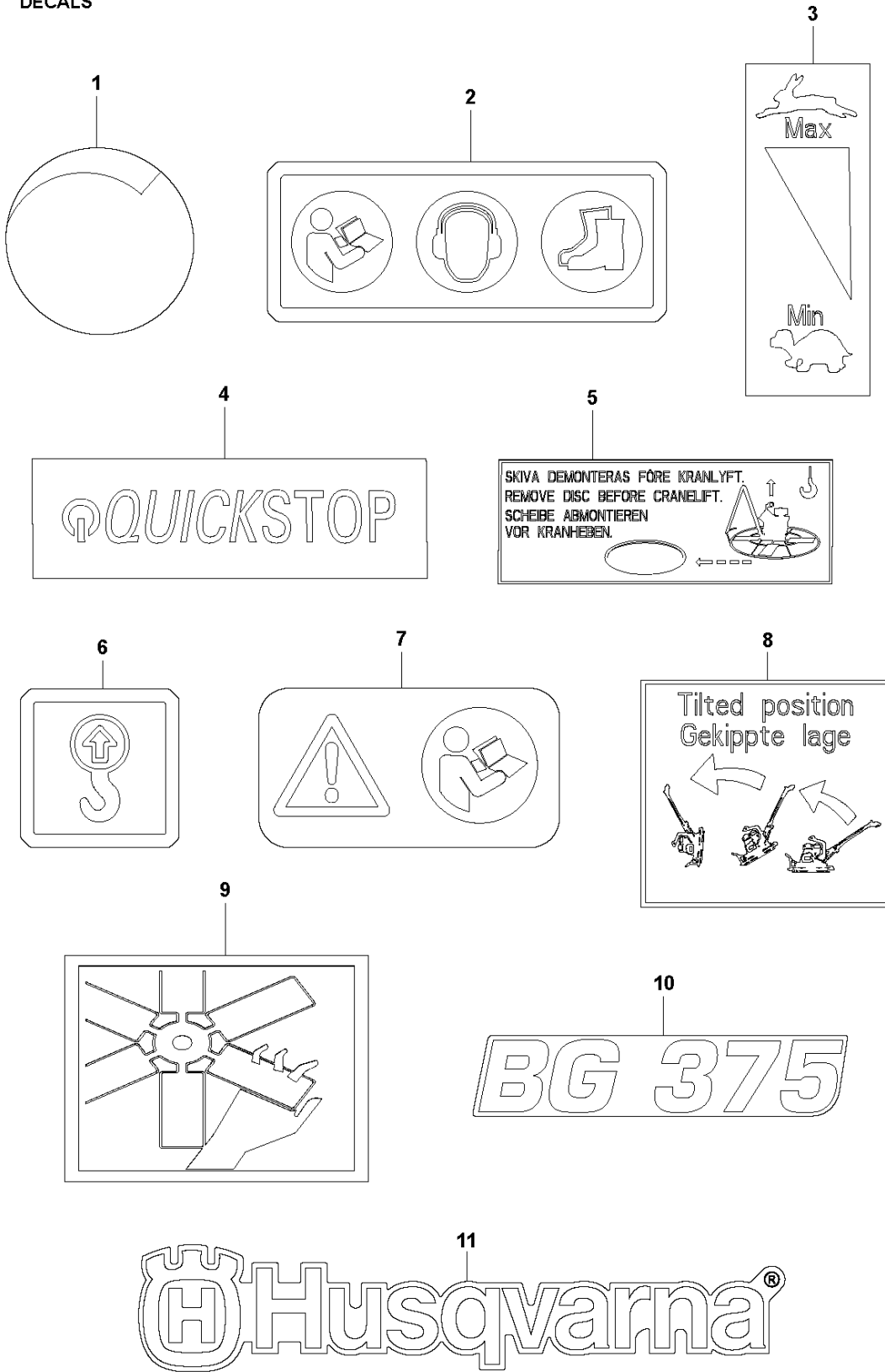

## DECALS

BG 375 F QP TP US, 967856401, 2020-06

Ref	Part No	Description	Remark	QTY KIT
1	594 24 58-01	DECAL	DECAL Blade Angle	1
2	594 65 96-01	LABEL	Safety	1
3	595 21 13-01	DECAL		1
4	595 11 91-01	DECAL		1
5	594 24 59-01	DECAL	Remove Floating Disc	1
6	594 66 09-01	LABEL	Lifting Point	1
7	594 86 97-01	LABEL	Safety, Read instruction	1
8	595 21 12-01	DECAL		1
9	594 16 30-01	DECAL	Cutting Hazard	1
10	595 09 73-01	DECAL	Brand	2
11	577 06 20-01	DECAL	Husqvarna logo	1

**G** BG 375 F QP TP US  
TRANSPORT DEVICE KIT

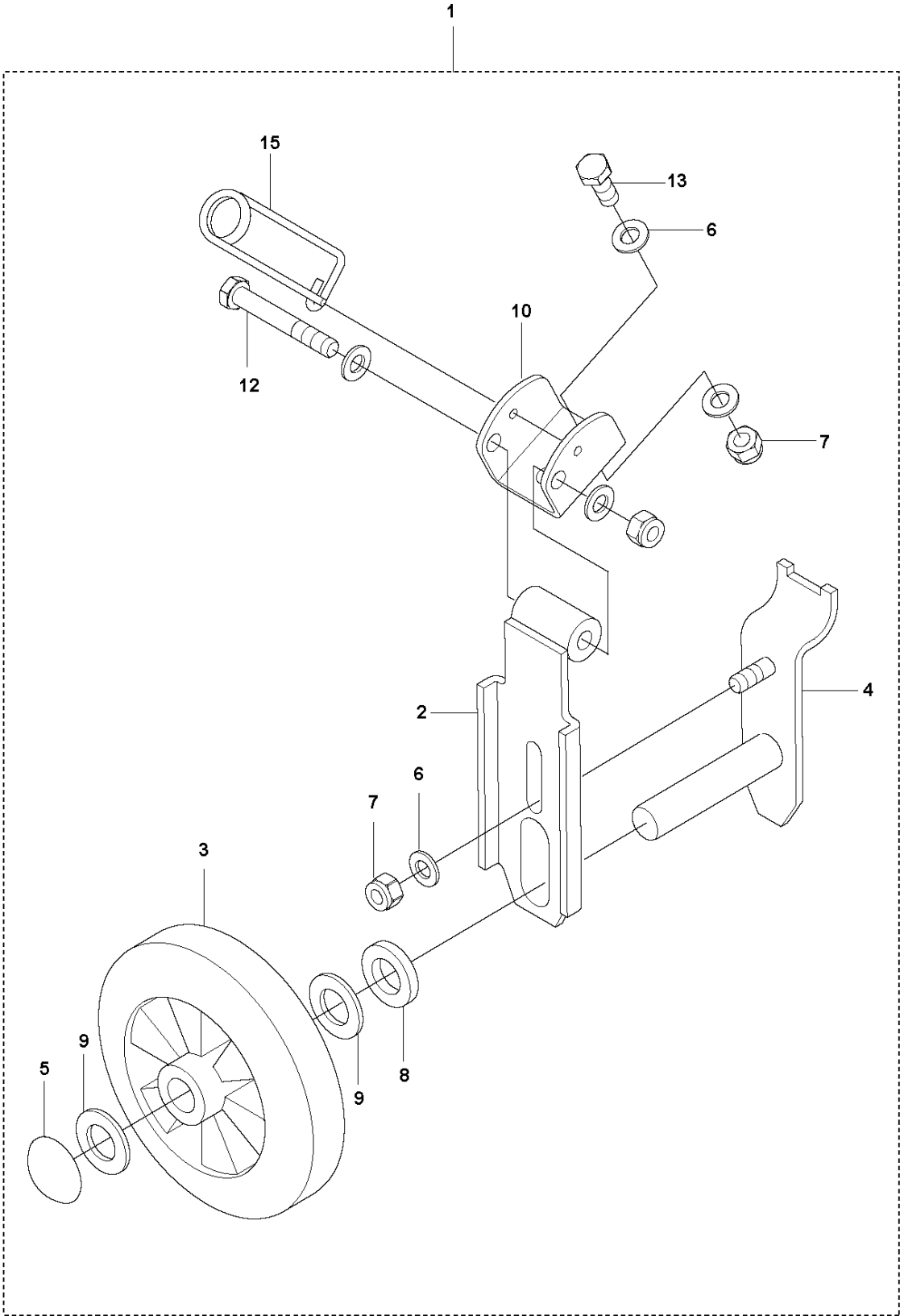

## TRANSPORT DEVICE KIT

BG 375 F QP TP US, 967856401, 2020-06

Ref	Part No	Description	Remark	QTY KIT	
1	594 75 15-01	TRANSPORT WHEEL	Transport device kit	1	
2	595 50 27-01	ARM		1	1
3	596 86 59-53	WHEEL		1	1
4	595 12 28-01	BRACKET		1	1
5	594 76 89-01	WASHER		1	1
6	595 11 33-01	WASHER	M10 ISO 7089 A2K 200 HV	7	1
7	594 12 29-01	LOCK NUT	M10 ISO 10511	4	1
8	594 12 43-01	WASHER	M20 DIN 6796 FZM-Y	1	1
9	596 86 59-57	WASHER	M20 ISO 7090 FZV 200HB	2	1
10	595 52 65-01	ATTACHMENT PLATE		1	1
12	596 88 97-10	SCREW	M10 x 70 DIN 931 - 8.8 zn	1	1
13	595 07 11-01	SCREW	M10x25 CL8.8 DIN933	2	1
15	594 16 18-01	PIN		1	1

**H** BG 375 F QP TP US  
SERVICE KIT - HONDA GX 160/200

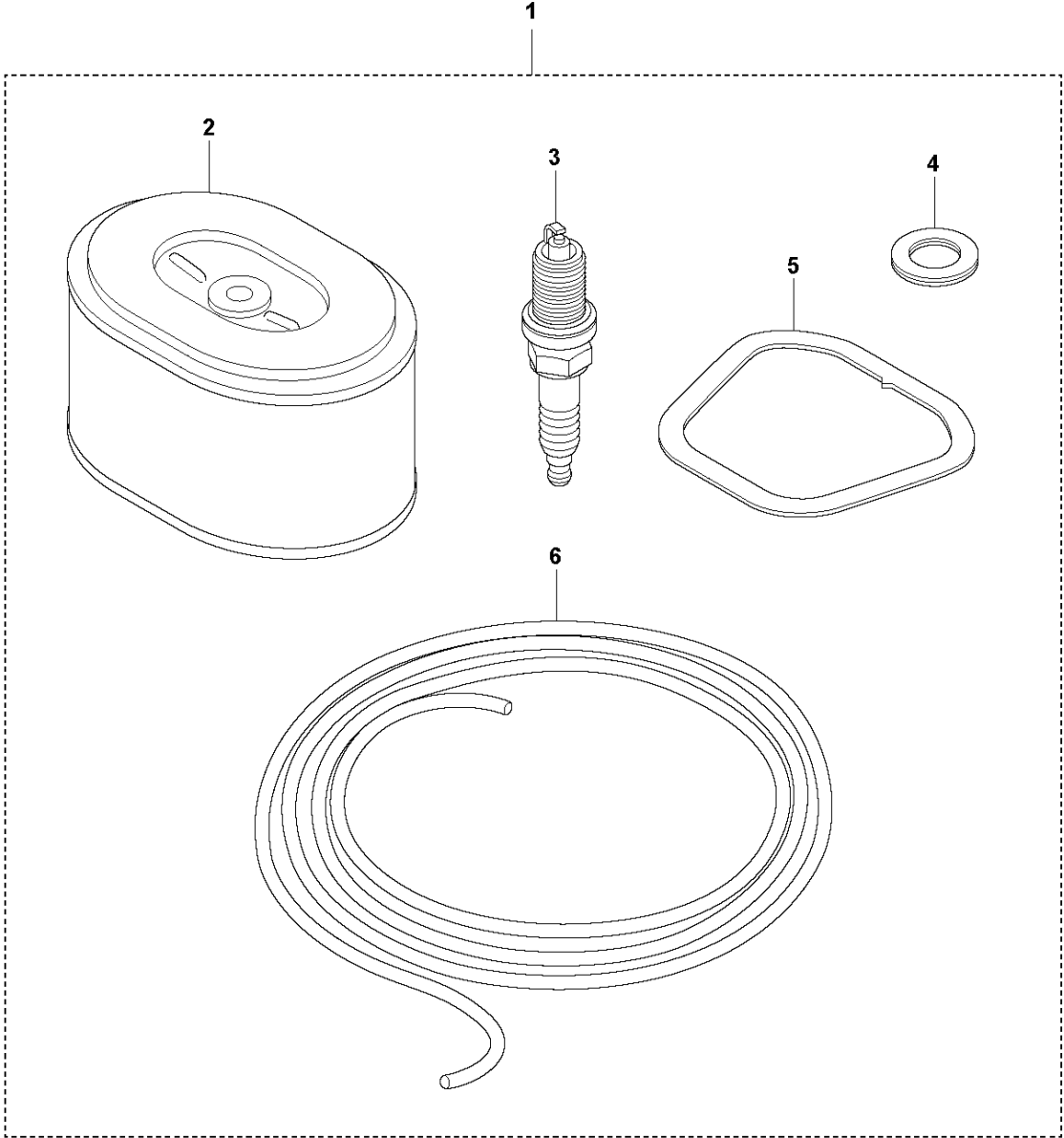



SERVICE KIT

BG 375 F QP TP US, 967856401, 2020-06

Ref	Part No	Description	Remark	QTY KIT	
1	594 20 02-01	SERVICE KIT		1	
2	594 30 21-01	AIR FILTER		1	1
3	594 54 43-01	SPARK PLUG	BPR6ES (NGK)	1	1
4	595 04 89-01	GASKET		1	1
5	594 31 30-01	GASKET		1	1
6	595 04 91-01	ROPE		1	1

**J** BG 375 F QP TP US  
MAINTENANCE KIT - HONDA GX 160/200 L

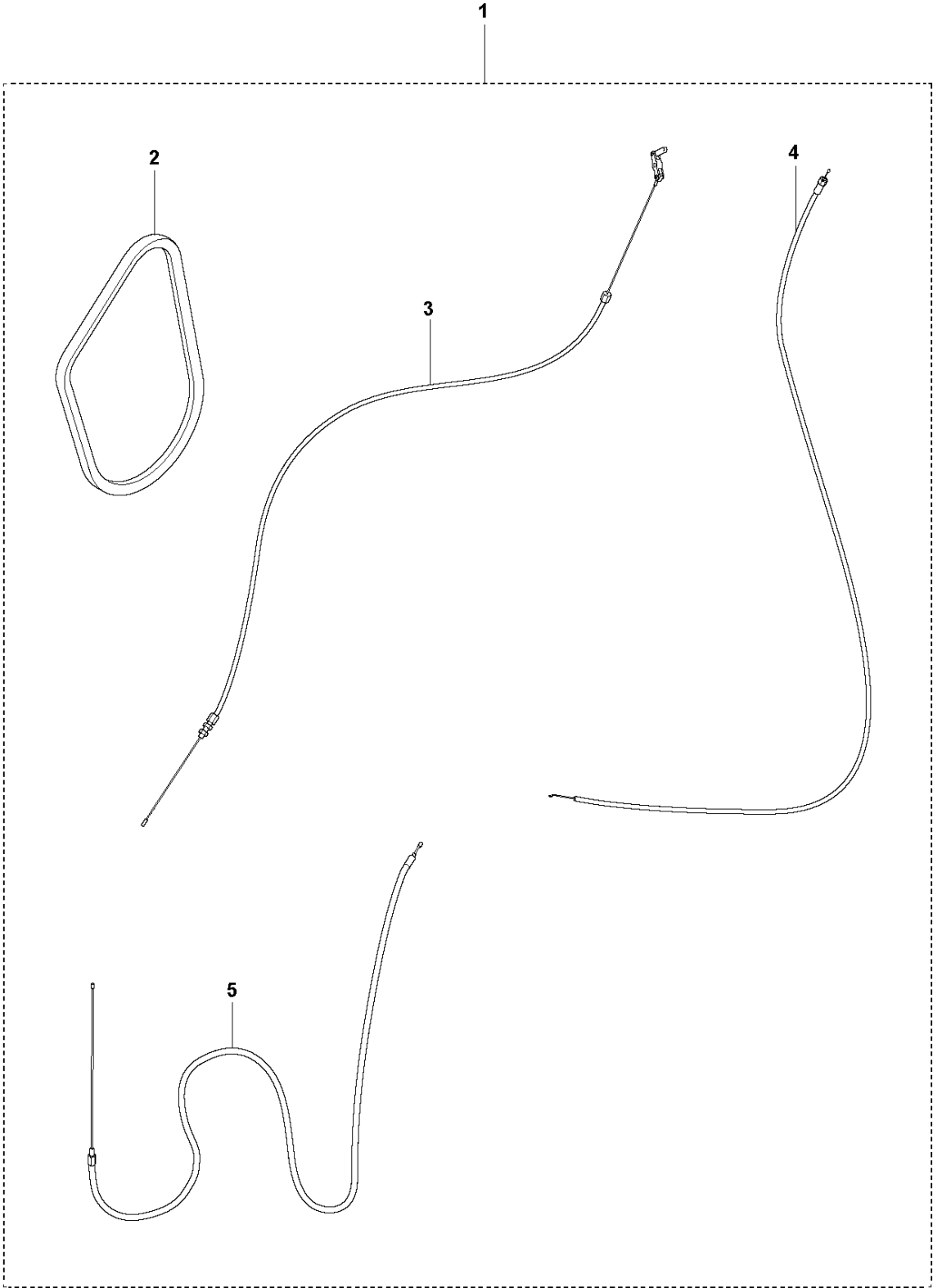

MAINTENANCE KIT

BG 375 F QP TP US, 967856401, 2020-06

Ref	Part No	Description	Remark	QTY KIT	
1	594 85 93-01	SERVICE KIT		1	
2	595 16 22-01	V-BELT		1	1
4	594 63 92-01	THROTTLE	Throttle cable	1	1
3	597 92 33-02	CABLE ASSY	Clutch cable, complete	1	1
5	594 63 90-01	WIRE	Blade adjuster cable	1	1

**K** BG 375 F QP TP US  
GEARBOX SEAL KIT

1

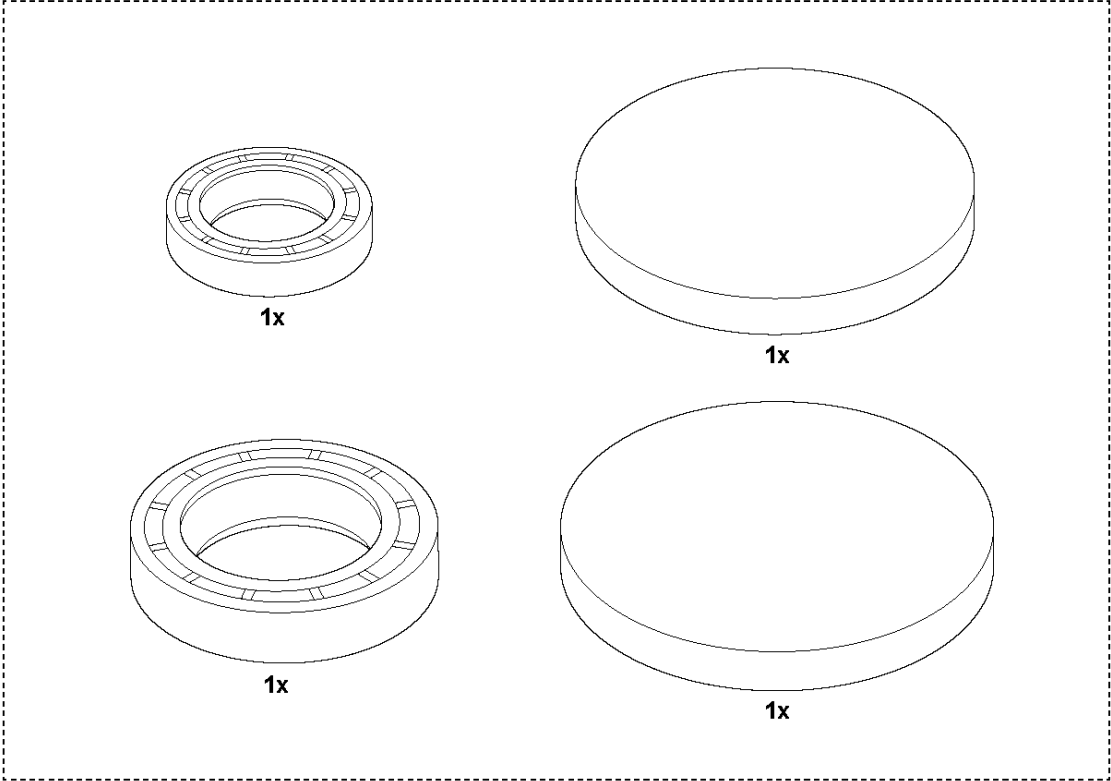

GEARBOX SEAL KIT

BG 375 F QP TP US, 967856401, 2020-06

Ref	Part No	Description	Remark	QTY KIT
1	594 20 69-01	SEAL	Gearbox seal kit (seals & plugs)	1