



SPARE PARTS LIST

DUST AND SLURRY MANAGEMENT

W 70, 2020-02

A W70
MOTOR

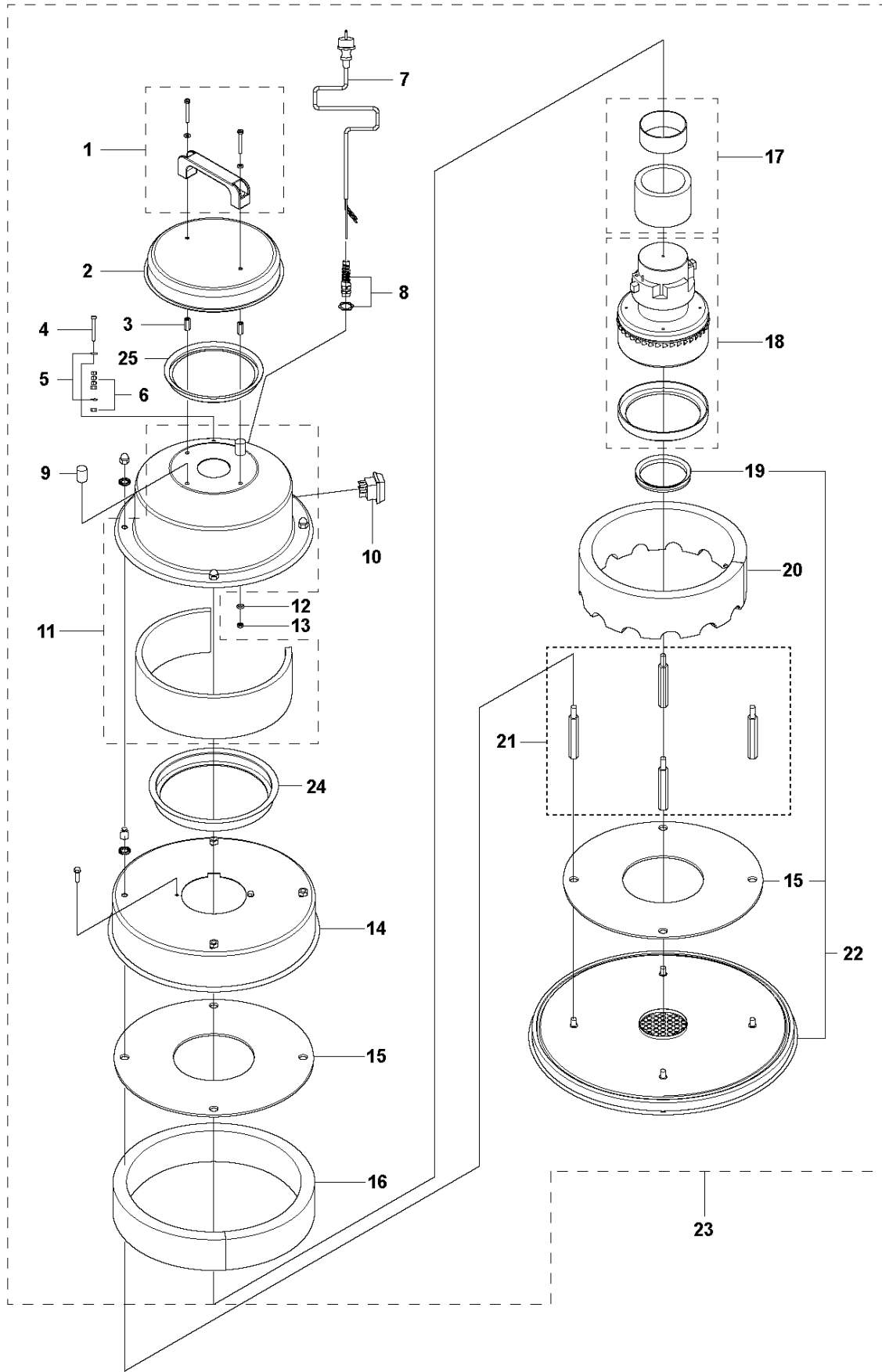

MOTOR

W 70, 2020-02

Ref	Part No	Description	Remark	QTY KIT
1	590 47 05-01	HANDLE KIT		1
2	590 47 06-01	CAP		1
3	591 76 51-01	NUT		2
4	591 76 18-01	SCREW		1
5	591 76 02-01	WASHER		2
6	591 75 97-01	NUT		7
7	593 71 74-03	POWER CORD	EU	1
7	593 71 74-01	POWER CORD	AUS	1
7	593 71 74-04	POWER CORD	UK	1
7	593 71 74-08	POWER CORD	US	1
8	590 40 25-01	CABLE GROMMET	EU, AUS	1
8	590 39 95-01	CABLE GROMMET	US, UK	1
9	591 75 09-01	SPACER		2
10	591 53 72-01	BUTTON		2
11	599 43 41-02	HOUSING ASSY		1
12	735 11 46-01	SPRING WASHER		3
13	591 75 97-01	NUT		7
14	591 71 71-02	HOUSING		1
15	591 73 15-01	PACKING		2
16	591 73 14-01	INSULATION		1
17	590 47 04-01	SEAL KIT		1
18	590 47 19-01	MOTOR KIT	120V	1
18	591 90 65-01	ENGINE	230V	1
19	591 73 07-01	V-RING		1
20	590 46 98-01	INSULATION		1
21	590 47 03-01	SPACER		1
22	590 47 02-01	TANK CAP		1
23	591 58 30-03	UNIT	AUS	1
23	591 58 30-02	UNIT	EU	1
23	591 58 30-04	UNIT	UK	1
23	591 58 30-05	UNIT	US	1
24	599 14 34-01	GASKET		1
25	599 14 33-01	GASKET		1

B W70
TANK

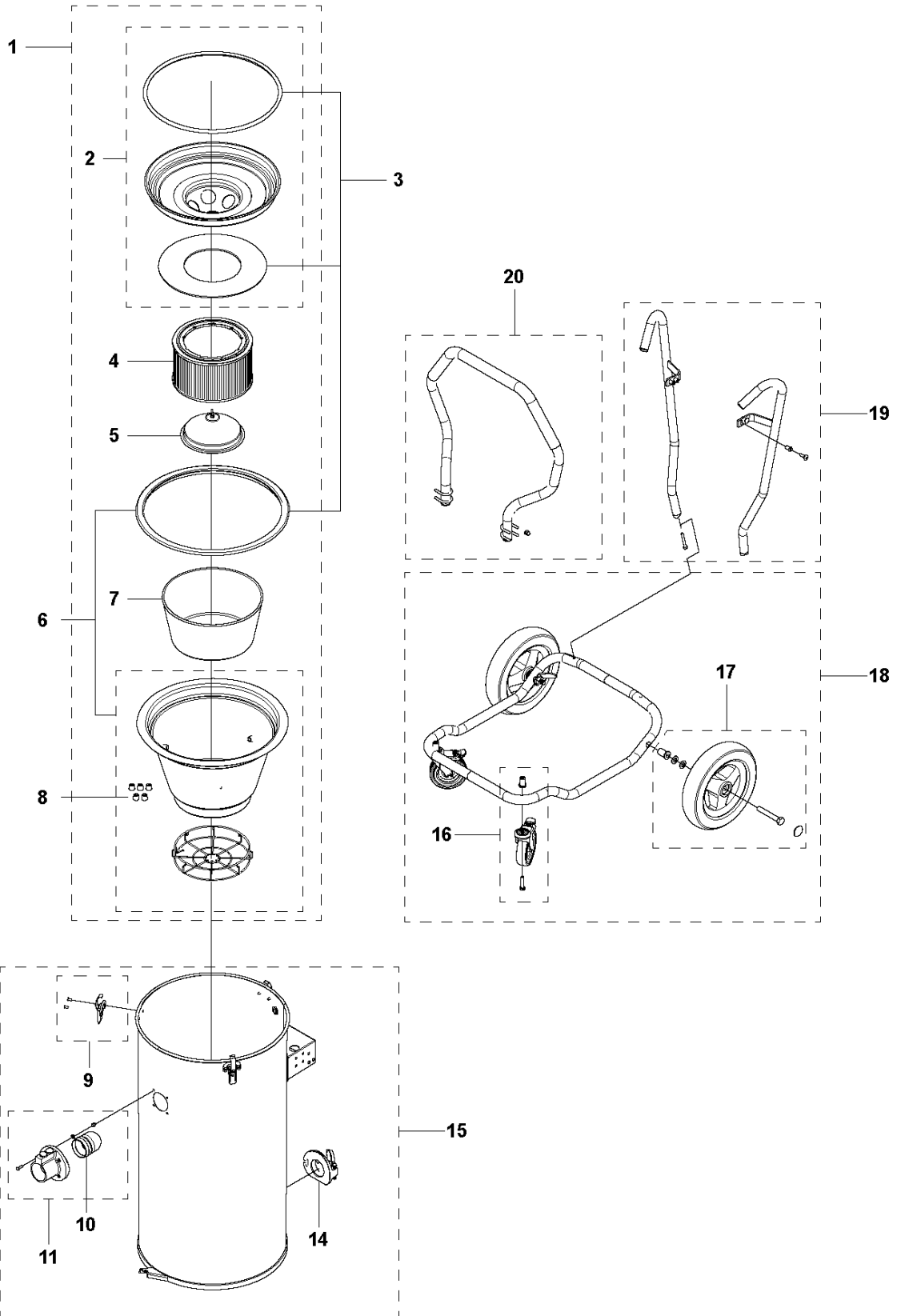

TANK

W 70, 2020-02

Ref	Part No	Description	Remark	QTY KIT
1	591 60 32-01	FILTER		1
2	590 47 09-01	FILTER		1
3	590 47 01-01	SEAL KIT		1
4	590 43 89-01	FILTER		1
4	598 40 01-01	FILTER	Hepa filter, optional	1
5	590 47 10-01	CAP		1
6	590 47 00-01	TUBE		1
7	590 47 57-01	FLOAT		1
8	590 47 11-01	PLUG KIT		1
9	590 39 64-01	HOLDER KIT		3
10	590 46 96-01	SCOOP		1
11	590 46 95-01	INLET		1
14	590 47 13-02	COVER KIT		1
15	599 43 42-02	TANK		1
16	590 39 72-01	WHEEL KIT		1
17	590 39 70-01	REAR WHEEL		1
18	590 47 12-02	FRAME		1
19	590 47 07-01	PROTECTION		1
20	590 47 14-01	STRAINER		1

C W70
ACCESSORIES

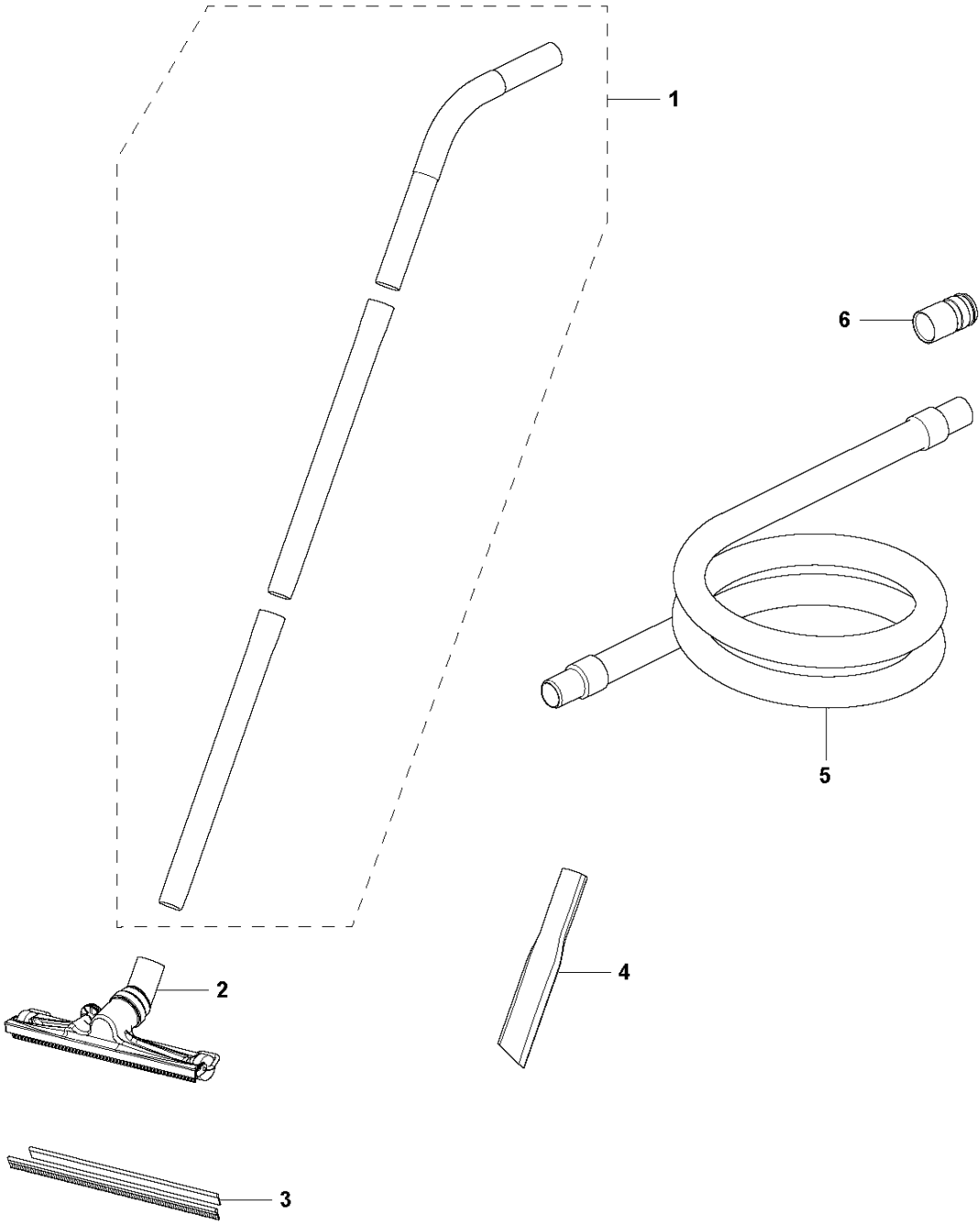

ACCESSORIES

W 70, 2020-02

Ref	Part No	Description	Remark	QTY KIT
1	590 42 86-01	TOOL		1
2	591 99 27-01	NOZZLE		1
3	590 42 85-01	TOOL		1
4	590 42 82-01	TOOL		1
5	590 42 79-01	HOSE KIT		1
6	590 43 75-01	HOSE		1

D W70
DECALS

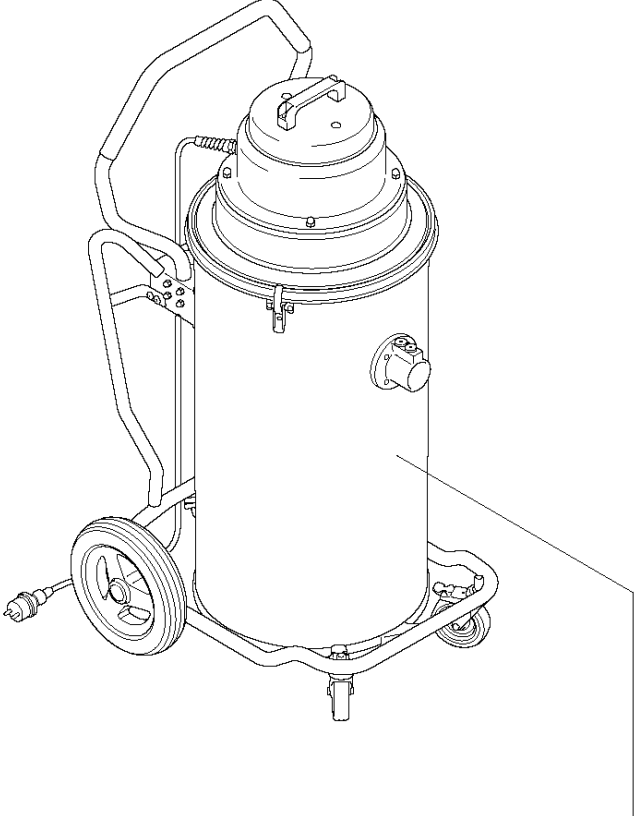

DECALS

W 70, 2020-02

Ref	Part No	Description	Remark	QTY KIT
1	590 74 99-17	DECAL		1