

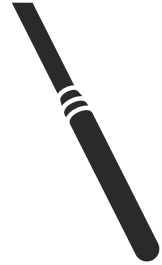

 **Husqvarna**[®]



AY 27, AY 37, AY 47, AY 57, AY 67, AY 77,
AY 87, AY 107, AY 157

Contents

Introduction.....	2	Troubleshooting.....	9
Safety.....	2	Storage and disposal.....	10
Operation.....	5	Technical data.....	11
Maintenance.....	6	EC Declaration of Conformity.....	13

Introduction

Product description

The product is a concrete vibrator. The product has a pneumatically operated motor that only contains 2 moving parts. Compressed air is supplied to the product through the air valve.

An automatic lubricator can be installed on the models AY 27, AY 37, AY 47, AY 57, AY 67, AY 77, AY 87 as an optional equipment. The automatic lubricator is supplied by the manufacturer of the air compressor.

Intended use

The product is for professional operation only. The product removes air bubbles from wet concrete. Do not use the product for other tasks.

Product overview

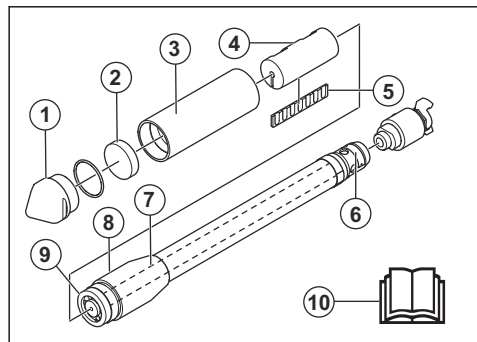

1. End cap
2. Front flange
3. Tube
4. Rotor
5. Lamella
6. Rating plate

7. Inner hose
8. Rear connector
9. Rear flange
10. Operator's manual

Rating plate

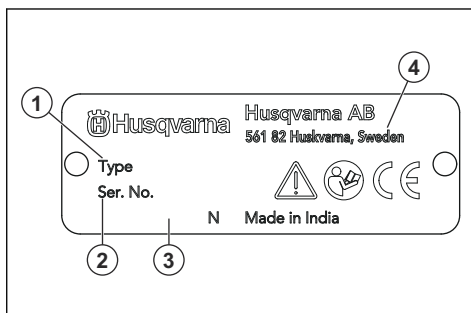

1. Product type
2. Serial number
3. Speed, rpm
4. Manufacturer

Product liability

As referred to in the product liability laws, we are not liable for damages that our product causes if:

- the product is incorrectly repaired.
- the product is repaired with parts that are not from the manufacturer or not approved by the manufacturer.
- the product has an accessory that is not from the manufacturer or not approved by the manufacturer.
- the product is not repaired at an approved service center or by an approved authority.

Safety

Safety definitions

Warnings, cautions and notes are used to point out specially important parts of the manual.



WARNING: Used if there is a risk of injury or death for the operator or bystanders if the instructions in the manual are not obeyed.



CAUTION: Used if there is a risk of damage to the product, other materials or the adjacent area if the instructions in the manual are not obeyed.

Note: Used to give more information that is necessary in a given situation.

General safety instructions



WARNING: Read the warning instructions that follow before you use the product.

- This product is a dangerous tool if you are not careful or if you use the product incorrectly. This product can cause serious injury or death to the operator or others. Before you use the product, you must read and understand the contents of this operator's manual.
 - Save all warnings and instructions.
 - Comply with all applicable laws and regulations.
 - The operator and the employer of the operator must know and prevent the risks during operation of the product.
 - Do not let a person operate the product unless they read and understand the contents of the operator's manual.
 - Do not operate the product unless you receive training before use. Make sure that all operators receive training.
 - Do not let a child operate the product.
 - Only let approved persons operate the product.
 - The operator is responsible for accidents that occur to other persons or their property.
 - Do not use the product if you are tired, ill, or under the influence of alcohol, drugs or medicine.
 - Always be careful and use your common sense.
 - This product produces an electromagnetic field during operation. This field can under some circumstances interfere with active or passive medical implants. To decrease the risk of serious injury or death, we recommend persons with medical implants to speak to their physician and the medical implant manufacturer before operating this product.
 - Keep the product clean. Make sure that you can clearly read signs and decals.
 - Do not use the product if it is defective.
 - Do not do modifications to this product.
 - Do not operate the product if it is possible that other persons have done modifications to the product.
- Make sure that you know how to stop the product quickly in an emergency.
 - The operator must have the physical strength that is necessary to operate the product safely.
 - Use personal protective equipment. Refer to *Personal protective equipment on page 4*.
 - Make sure that only approved persons are in the work area.
 - Keep the work area clean and bright.
 - Make sure that you are in a safe and stable position during operation.
 - Make sure that there is no grease or oil on the handle.
 - Do not use the product in areas where fire or explosions can occur.
 - The product can cause objects to eject at high speed. Make sure that all persons in the work area use approved personal protective equipment. Remove loose objects from the work area.
 - Before you go away from the product, stop the product and disconnect the power source.
 - Make sure that clothes, long hair and jewelry do not get caught in moving parts.
 - Do not sit on the product.
 - Do not hit the product.
 - Make sure that you or other persons cannot get caught in and fall on cables, hoses and shafts in the work area.
 - Before you operate the product, find out if there are hidden wires, electrical cables or other sources of electricity. Do not operate the product unless you know that it is in a safe work area.

Vibration safety



WARNING: Read the warning instructions that follow before you use the product.

- During operation of the product, vibrations go from the product to the operator. Regular and frequent operation of the product can cause or increase the degree of injuries to the operator. Injuries can occur in fingers, hands, wrists, arms, shoulders, and/or nerves and blood supply or other body parts. The injuries can be debilitating and/or permanent, and can increase gradually during weeks, months or years. Possible injuries include damage to the blood circulation system, the nervous system, joints, and other body structures.
- Symptoms can occur during operation of the product or at other times. If you have symptoms and continue to operate the product, the symptoms can increase or become permanent. If these or other symptoms occur, get medical aid:
 - Numbness, loss of feeling, tingling, pricking, pain, burning, throbbing, stiffness, clumsiness, loss of strength, changes in skin color or condition.

Safety instructions for operation



WARNING: Read the warning instructions that follow before you use the product.

- Symptoms can increase in cold temperatures. Use warm clothing and keep your hands warm and dry when you operate the product in cold environments.
- Do maintenance on and operate the product as given in the operator's manual, to keep a correct vibration level.
- The product has a vibration damping system that decreases the vibrations from the handles to the operator. Let the product do the work. Do not push the product with force. Hold the product at the handles lightly, but make sure that you control the product and operate it safely. Do not push the handles into the end stops more than necessary.
- Keep your hands on the handle or handles only. Keep all other body parts away from the product.
- Stop the product immediately if strong vibrations suddenly occurs. Do not continue the operation before the cause of the increased vibrations is removed.
- High noise levels and long-term exposure to noise can cause noise-induced hearing loss.
- To keep the noise level to a minimum, do maintenance on and operate the product as given in the operator's manual.
- Use approved hearing protection while you operate the product.
- Listen for warning signals and voices when you use hearing protection. Remove the hearing protection when the product is stopped, unless hearing protection is necessary for the noise level in the work area.

Personal protective equipment



WARNING: Read the warning instructions that follow before you use the product.

- Always use approved personal protective equipment when you operate the product. Personal protective equipment cannot fully prevent injury but it decreases the degree of injury if an accident does occur. Let your dealer help you select the correct personal protective equipment.
- Regularly do a check of the condition of the personal protective equipment.
- Use an approved protective helmet.
- Use approved hearing protection.
- Use approved respiratory protection.
- Use approved eye protection with side protection.
- Use protective gloves.
- Use boots with steel toe-cap and non-slip sole.
- Use approved work clothing or equivalent close-fitting clothing that has long sleeves and long legs.

Safety instructions for pneumatic air hoses



WARNING: A loose pneumatic air hose can move around randomly and with force. There is a risk of injury or death if the operator or bystanders are hit by a pneumatic air hose. Read the warning instructions that follow before you use the product.

- Examine the pneumatic air hose and the connectors for damage. Replace damaged parts immediately.
- Make sure that all connectors for the pneumatic air hose are correctly installed.
- Make sure that the pneumatic air hose is correctly connected.
- Do not hold the pneumatic air hose to lift or move the product.
- Do not disconnect a pneumatic air hose that is pressurized. Before you disconnect the pneumatic air hose, stop the air compressor and then operate the start and stop function on the product to release the remaining pressure.

Dust safety



WARNING: Read the warning instructions that follow before you use the product.

- Operation of the product can cause dust in the air. Dust can cause serious injury and permanent health problems. Silica dust is regulated as harmful by several authorities. These are examples of such health problems:
 - The fatal lung diseases chronic bronchitis, silicosis and pulmonary fibrosis
 - Cancer
 - Birth defects
 - Skin inflammation
- Use correct equipment to decrease the quantity of dust and fumes in the air and to decrease dust on work equipment, surfaces, clothing and body parts. Examples of controls are dust collection systems and water sprays to bind dust. Decrease dust at the source where possible. Make sure that the equipment is correctly installed and used and that regular maintenance is done.
- Use approved respiratory protection. Make sure that the respiratory protection is applicable for the dangerous materials in the work area.
- Make sure that the airflow is sufficient in the work area.
- If it is possible, point the exhaust of the product where it cannot cause dust to go into the air.

Noise safety



WARNING: Read the warning instructions that follow before you use the product.

- Do not point the airflow in the direction of your body or other persons. Air can go into the blood circulation and cause death.
- Do not use compressed air to remove dirt from your clothing.
- If you use claw couplings, install lockpins and use safety cables. Lockpins and safety cables prevent failure in the connections between pneumatic air hoses and between a pneumatic air hose and a tool.
- Clean the product to remove dangerous material before you do the maintenance.
- Disconnect the product from the power source before you do the maintenance.
- Do not do modifications to the product. Modifications that are not approved by the manufacturer can cause serious injury or death.
- Always use original accessories and spare parts. Accessories and spare parts that are not approved by the manufacturer, can cause serious injury or death.

Safety instructions for maintenance



WARNING: Read the warning instructions that follow before you use the product.

- If the maintenance is not done correctly and regularly, the risk of injury and damage to the product increases.
- Use personal protective equipment. Refer to *Personal protective equipment on page 4.*
- Replace damaged, worn or broken parts.
- Only do the maintenance as given in this operator's manual. Let an approved service agent do all other servicing.
- After maintenance, do a check of the vibration level in the product. If it is not correct, speak to an approved service agent.
- Let an approved service agent do servicing on the product regularly.

Operation

Introduction



WARNING: Read and understand the safety chapter before you use the product.

To start and stop the product

1. Lubricate the product. Refer to *To lubricate the product on page 6.*
2. Drain the water tank of the air compressor. Refer to the operator's manual for the air compressor.
3. Connect the product to the air compressor.
4. Start the air compressor.
5. If there is no vibration in the vibrator head, hit the side of the vibrator head to start the vibration.
6. To stop the product, stop the air compressor.
7. Put some oil in the vibrator head and push some air into the product to prevent damage to the product.

To operate the product



CAUTION: Do not use the product to move the concrete to the side.

1. Fill concrete in equally thick layers, 30–50 cm / 12–19 in. (B).

2. Put the vibrator head approximately 15 cm / 6 in. (A) down into the nearest lower layer of concrete. This causes the layers of concrete to mix correctly.

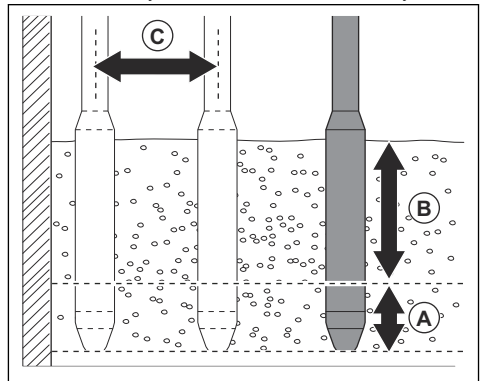

3. Wait approximately 10–20 seconds until the surface around the vibrator head is shiny and no air bubbles come to the surface.

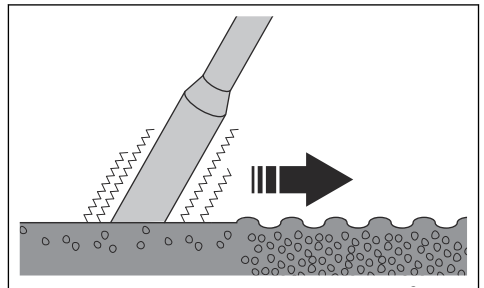

- Remove the vibrator head slowly to let the concrete fill the hole from the vibrator head.
- Put the vibrator head down into the concrete at a distance of 30–50 cm / 12–19 in. (C) from where you put it before.

- Do step 4 and 5 again and again. Continue until the air bubbles are fully removed from the area of concrete.

Maintenance

Introduction



WARNING: Read and understand the safety chapter before you do maintenance on the product.

To lubricate the product

The product comes without oil. If there is an automatic lubricator installed on the air compressor, the oil that is supplied through the air flow is sufficient. If there is not an automatic lubricator installed on the air compressor, the product must be manually lubricated. Lubricate the product each day or each 4 hours during continuous operation.

- Put 4 cm³ of oil into the release coupling on the handle. Refer to *Technical data on page 11* for the correct type of oil.

To clean the product



CAUTION: Do not use a high-pressure washer to clean the product.

- Use running water from a hose to clean the product.
- Remove concrete from the surfaces of the product after each operation before the concrete becomes hard.
- Remove grease and oil from the handle.

To disassemble and assemble the air valve coupling

- Remove the clamp coupling (A) from the product body (B).

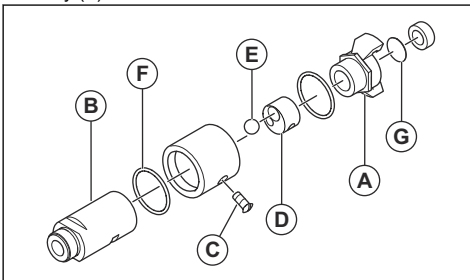

Note: The product body (B) has a right hand thread.

- Remove the screw (C).
- Remove the ball valve (D) and the air valve ball (E).
- Replace the O-ring (F) and the air filter (G).
- Assemble in the opposite sequence.

To disassemble and assemble the vibrator head (AY 157)

- Remove the 3 screws (A).

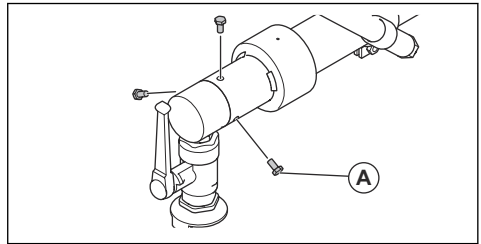

- Cut the clamp (C) and push out the hose nipple (B).

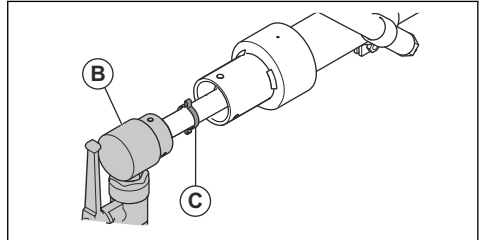

- Put the tube of the vibrator head (D) in a vise. Remove the end cap (E) and the rear holder (F).

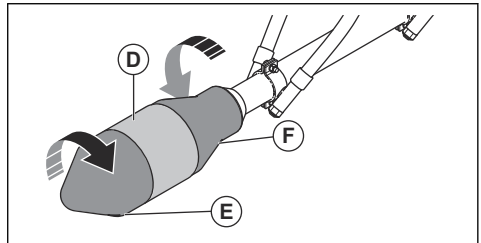

Note: The end cap (E) has a right hand thread. The rear holder (F) has a left hand thread.

- Replace the lamella (H), the O-rings (I and K) and the clamps (C and J).

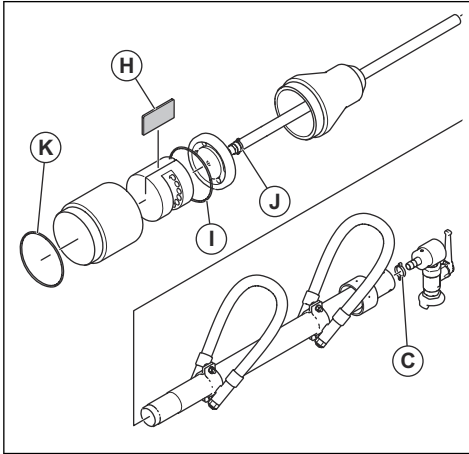

- Lubricate all the parts lightly.
- Assemble the vibrator head in the opposite sequence.
- Tighten the end cap to the correct torque. Refer to *Tightening torque and threadlocker type on page 8*.

Overview (AY 27, AY 37, AY 47, AY 57, AY 67, AY 77, AY 87, AY 107)

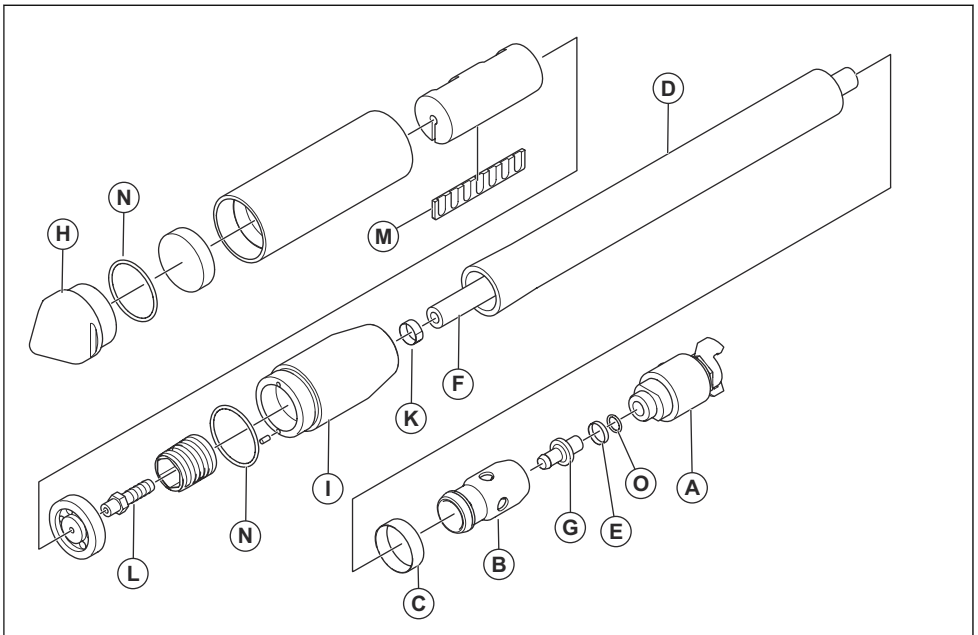

To disassemble and assemble the vibrator head (AY 27, AY 37, AY 47, AY 57, AY 67, AY 77, AY 87, AY 107)

Refer to *Overview (AY 27, AY 37, AY 47, AY 57, AY 67, AY 77, AY 87, AY 107) on page 7* for the illustration related to this task.

- Disconnect the air valve (A) from the hose holder (B).
- Cut the clamp (C).
- Remove the hose (D) from the hose holder (B).
- Cut the clamp (E) and release the inlet hose (D) from the hose nipple (G).

- Put the tube in a vise and remove the end cap (H) and the hose holder (I).

Note: The end cap (H) has a right hand thread. The hose holder (I) has a left hand thread.

- Remove the hose sleeve (J) and disassemble the exhaust hose (D).
- Cut the clamp (K) and release the inlet hose from the hose nipple (L).
- Replace the lamella (M), the O-rings (N and O) and the clamps (C, E and K).
- Make sure that the lamella goes smoothly into the rotor slot. If it is necessary, rub the lamella with an emery cloth.
- Lubricate all the parts lightly.
- Assemble the vibrator head in the opposite sequence.
- Tighten the end cap and the hose holder to the correct torque. Refer to *Tightening torque and threadlocker type on page 8*.

To examine the air filter

- Disassemble the air valve coupling. Refer to *To disassemble and assemble the air valve coupling on page 6*.

- Examine the air filter. Replace the air filter if it is clogged.

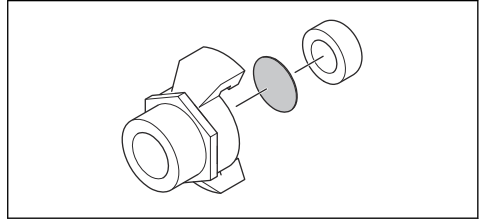

To clean and examine the vibrator head

Note: Replace the O-rings regularly.

- Examine the vibrator head for damage and wear. Replace damaged parts.
- Clean all parts.
- Fill the vibrator head with oil, refer to *To lubricate the product on page 6*.
- Examine the end cap for damage. Replace the end cap if it is damaged.

Tightening torque and threadlocker type

Vibrator head	End cap threadlocker	Tightening torque, Nm	
		End cap	Hose holder
AY 27	LOCTITE®270™	21	21
AY 37	LOCTITE®270™	50	50
AY 47	LOCTITE®270™	265	265
AY 57	LOCTITE®270™	340	340
AY 67	LOCTITE®270™	600	600
AY 77	LOCTITE®270™	880	880
AY 87	LOCTITE®270™	1200	1200
AY 107	LOCTITE®270™	1700	1700
AY 157	LOCTITE®270™	N/A	N/A

Troubleshooting

Problem	Cause	Solution
The product does not start.	There is no air pressure.	Examine the air flow and the air pressure.
	There is no air flow.	Make sure that the air compressor is on and that the product is correctly connected to the hose.
	The ball valve is closed.	Open the ball valve.
	The air exhaust is blocked.	Remove the blockage.
The air goes directly through the exhaust or the product vibrations are slow.	The rotor is blocked.	Shake the tube carefully when the tube is pressurised.
		Disassemble the end cap and clean the parts.
	The air pressure is too low to start the product.	Measure the air pressure. Refer to <i>Technical data on page 11</i> .
	The air flow is too low to start the product.	Measure the air flow. Refer to <i>Technical data on page 11</i> .
	There is a leak in the supply hoses.	Attach the clamps correctly on the supply hoses.
		Replace the supply hoses if it is necessary.
	The product is not sufficiently lubricated.	Lubricate the product, refer to <i>To lubricate the product on page 6</i> .
	The ball valve is not fully opened.	Open the ball valve fully.
The lamella is worn out.	Replace the lamella.	
The sealing on the ball valve coupling has a leak.	Replace the sealing.	
The vibration decreases when the vibrator head is put into concrete.	The air pressure is too low to start the product.	Measure the air pressure. Refer to <i>Technical data on page 11</i> .
	The air flow is too low to start the product.	Measure the air flow. Refer to <i>Technical data on page 11</i> .
	There is a leak in the supply hoses.	Attach the clamps correctly on the supply hoses.
		Replace the supply hoses if it is necessary.
	The product is not sufficiently lubricated.	Lubricate the product, refer to <i>To lubricate the product on page 6</i> .
	The ball valve is not fully opened.	Open the ball valve fully.
	The lamella is worn out.	Replace the lamella.
The tube is damaged or defective.	Replace the tube.	
The product does not operate in a dusty environment.	There is sand or dust in the vibrator head.	Disassemble and clean all the parts with fuel. Then lubricate all parts and assemble the vibrator head.
	The air exhaust is blocked.	Remove the blockage from the air exhaust.

Problem	Cause	Solution
The product does not operate in a moist environment.	Moist has mixed with the oil in the product.	Disassemble and clean all the parts with fuel. Then lubricate all parts and assemble the vibrator head.
	The lamella absorbs water and causes a blockage in the rotor.	Drain the water tank of the air compressor.
		Disassemble and clean all the parts with fuel. Then lubricate all parts and replace the lamella. Assemble the parts. Put the product in storage with the vibrator head up and the ball valve open. Put a container below the product to collect the fuel that comes out.

Storage and disposal

Storage

- Clean the product before storage.
- Keep the product in a dry and frost-free area.
- Keep the product in a locked area to prevent access for children or persons that are not approved.

Disposal of the product

- Obey the local recycling requirements and applicable regulations.
- When the product no longer is used, send it to the dealer or discard it at a recycling location.

Technical data

Technical data

	AY 27	AY 37	AY 47	AY 57	AY 67	AY 77	AY 87	AY 107	AY 157
Air consumption, m ³ /min	0.36	0.46	0.70	1.00	1.00	1.37	1.60	1.90	2.70
Speed at full load, min-1	21000	19000	18000	18000	17500	16000	15900	15000	12000
Weight, kg/lb	0.7/1.5	1.5/3.3	2.8/6.2	4.5/9.9	7.9/17.4	8.9/19.6	9.7/21.4	17.7/39	28/61.7
Noise emissions									
Sound pressure level L _p at the operators ear, dB(A) ¹	84.50	89.20	95.80	95.00	94.00	98.00	94.00	96.30	92.40
Weighted effective acceleration uncertainty (K) m/s ² ²	0.51	1.02	2.39	2.13	2.10	2.38	1.95	2.91	12.29
Uncertainty (K)	0.05	-	-	0.21	1.17	0.87	-	-	-

Oil type	Cold temperatures	Medium temperatures	Hot temperatures
Engine oil	Fluid engine oil with viscosity 5W40	Standard engine oil with viscosity 10W40	High viscosity oil with viscosity 20W40-20W50
Pneumatic tool oil	Non-detergent oil with 20 to 30 (SAE) viscosity		

Noise and vibration declaration statement

These declared values were obtained by laboratory type testing in accordance with the stated directive or standards and are suitable for comparison with the declared values of other products tested in accordance with the same directive or standards. These declared values are not suitable for use in risk assessments and values measured in individual work places may be higher. The actual exposure values and risk of harm experienced by an individual user are unique and depend upon the way the user works, in what material the product is used, as well as upon the exposure time and the physical condition of the user, and the condition of the product.

¹ Noise level measured in air at 1m from the product according to EN ISO 6081. Uncertainty: ± 3dB

² Weighted effective acceleration measured in water driving one poker, on the hose, at 2 metres from the end of the poker (m/s²), according to EN ISO 5349-1.

Product dimensions

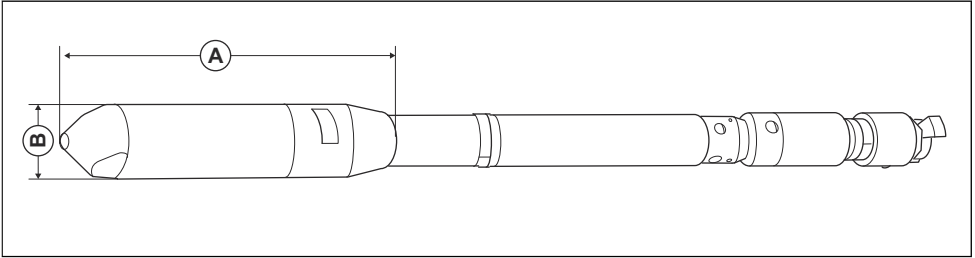

Type	AY 27	AY 37	AY 37	AY 57	AY 67	AY 77	AY 87	AY 107	AY 157
A Length, mm/in.	254 (9.99)	267 (10.50)	316 (12.44)	344 (13.54)	365 (14.37)	398 (15.66)	410 (16.14)	415 (16.33)	430 (16.92)
B Diameter, mm/in.	26 (1.02)	36 (1.42)	47 (1.85)	56 (2.20)	67 (2.64)	77 (3.03)	87 (3.43)	108 (4.25)	155 (6.10)

EC Declaration of Conformity

EC Declaration of Conformity

We, **Husqvarna AB**, SE-561 82 Huskvarna, Sweden, tel: +46-36-146500, declare on our sole responsibility that the product:

Description	Concrete Vibrator
Brand	Husqvarna
Type/Model	AY 27/37/47/57/67/77/87/107/157
Identification	Serial numbers dating from 2020 and onwards

complies fully with the following EU directives and regulations:

Directive/Regulation	Description
2006/42/EC	"relating to machinery"

and that the following harmonized standards and/or technical specifications are applied;

EN 12649:2008+A1:2011

Partille, 2020-03-06



Martin Huber

R&D Director, Concrete Surfaces & Floors

Husqvarna AB, Construction Division

Responsible for technical documentation



www.husqvarnacp.com

Original instructions

1140668-26



2020-09-25