

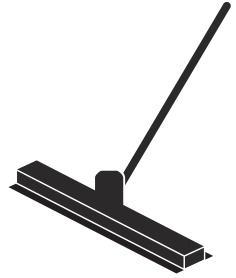

**Husqvarna**<sup>®</sup>



**BV 20H**

---

# Contents

---

Introduction.....	2	Maintenance.....	5
Safety.....	2	Storage and disposal.....	5
Assembly.....	4	Technical data.....	6
Operation.....	4		

---

## Introduction

---

### Product description

The product is a manually operated concrete screed.

### Intended use

The product is for professional operation only. The product is used for compaction of concrete. The product makes the concrete surface smooth.

### Product overview

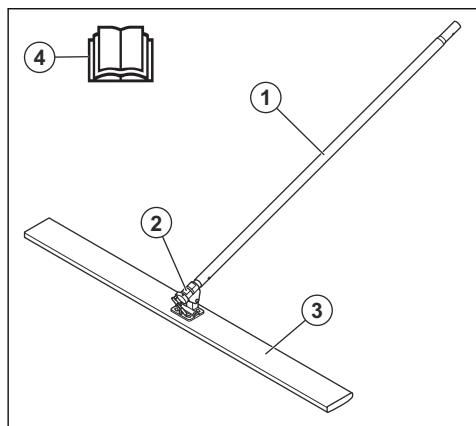

1. Handle
2. Swivel
3. Beam
4. Operator's manual

### Product liability

As referred to in the product liability laws, we are not liable for damages that our product causes if:

- the product is incorrectly repaired.
- the product is repaired with parts that are not from the manufacturer or not approved by the manufacturer.
- the product has an accessory that is not from the manufacturer or not approved by the manufacturer.
- the product is not repaired at an approved service center or by an approved authority.

---

## Safety

---

### Safety definitions

Warnings, cautions and notes are used to point out specially important parts of the manual.



**WARNING:** Used if there is a risk of injury or death for the operator or bystanders if the instructions in the manual are not obeyed.



**CAUTION:** Used if there is a risk of damage to the product, other materials or the adjacent area if the instructions in the manual are not obeyed.

**Note:** Used to give more information that is necessary in a given situation.

### General safety instructions



**WARNING:** Read the warning instructions that follow before you use the product.

- This product is a dangerous tool if you are not careful or if you use the product incorrectly. This product can cause serious injury or death to the operator or others. Before you use the product, you

must read and understand the contents of this operator's manual.

- Save all warnings and instructions.
- Comply with all applicable laws and regulations.
- The operator and the employer of the operator must know and prevent the risks during operation of the product.
- Do not let a person operate the product unless they read and understand the contents of the operator's manual.
- Do not operate the product unless you receive training before use. Make sure that all operators receive training.
- Only let approved persons operate the product.
- The operator is responsible for accidents that occur to other persons or their property.
- Do not use the product if you are tired, ill, or under the influence of alcohol, drugs or medicine.
- Always be careful and use your common sense.
- Keep the product clean. Make sure that you can clearly read signs and decals.
- Do not use the product if it is defective.
- Do not change this product.
- Do not operate the product if it is possible that it is changed by other persons.

## Safety instructions for operation



**WARNING:** Read the warning instructions that follow before you use the product.

- The operator must have the physical strength that is necessary to operate the product safely.
- Use personal protective equipment. Refer to *Personal protective equipment on page 3*.
- Make sure that only approved persons are in the work area.
- Keep the work area clean and bright.
- Make sure that you are in a safe and stable position during operation.
- Make sure that there is no grease or oil on the handle.
- Make sure that all persons in the work area use approved personal protective equipment. Remove loose objects from the work area.
- Do not sit on the product.
- Do not hit the product.
- Make sure that you or other persons cannot get caught in and fall on cables, hoses and shafts in the work area.
- Before you operate the product, find out if there are hidden wires, electrical cables or other sources of electricity. Do not operate the product unless you know that it is in a safe work area.

## Dust safety



**WARNING:** Read the warning instructions that follow before you use the product.

- Operation of the product can cause dust in the air. Dust can cause serious injury and permanent health problems. Silica dust is regulated as harmful by several authorities. These are examples of such health problems:
  - The fatal lung diseases chronic bronchitis, silicosis and pulmonary fibrosis
  - Cancer
  - Birth defects
  - Skin inflammation
- Use correct equipment to decrease the quantity of dust and fumes in the air and to decrease dust on work equipment, surfaces, clothing and body parts. Examples of controls are dust collection systems and water sprays to bind dust. Decrease dust at the source where possible. Make sure that the equipment is correctly installed and used and that regular maintenance is done.
- Use approved respiratory protection. Make sure that the respiratory protection is applicable for the dangerous materials in the work area.
- Make sure that the airflow is sufficient in the work area.
- If it is possible, point the exhaust of the product where it cannot cause dust to go into the air.

## Personal protective equipment



**WARNING:** Read the warning instructions that follow before you use the product.

- Always use approved personal protective equipment when you operate the product. Personal protective equipment cannot fully prevent injury but it decreases the degree of injury if an accident does occur. Let your dealer help you select the correct personal protective equipment.
- Regularly do a check of the condition of the personal protective equipment.
- Use an approved protective helmet.
- Use approved hearing protection.
- Use approved respiratory protection.
- Use approved eye protection with side protection.
- Use protective gloves.
- Use boots with steel toe-cap and non-slip sole.
- Use approved work clothing or equivalent close-fitting clothing that has long sleeves and long legs.

## Safety instructions for maintenance

---



**WARNING:** Read the warning instructions that follow before you use the product.

---

- If the maintenance is not done correctly and regularly, the risk of injury and damage to the product increases.
  - Use personal protective equipment. Refer to *Personal protective equipment on page 3*.
  - Clean the product to remove dangerous material before you do the maintenance.
  - Do not change the product. Modifications that are not approved by the manufacturer can cause serious injury or death.
  - Always use original accessories and spare parts. Accessories and spare parts that are not approved by the manufacturer, can cause serious injury or death.
  - Replace damaged, worn or broken parts.
  - Only do the maintenance as given in this operator's manual. Let an approved service agent do all other servicing.
  - Let an approved service agent do servicing on the product regularly.
- 

## Assembly

---

### To assemble and disassemble the handle

1. Assemble the handle (A). Make sure that the locking pins (B) engage in the holes in the handle tube.

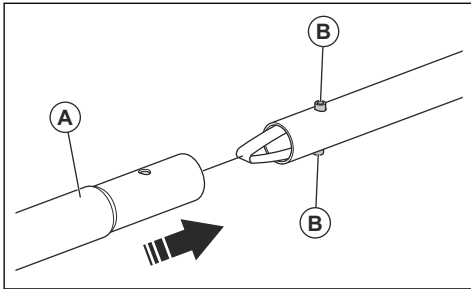

2. Disassemble the product in the opposite sequence.
- 

## Operation

---

### Introduction

---



**WARNING:** Read and understand the safety chapter before you use the product.

---

### To do before you operate the product

- Read the operator's manual carefully and make sure that you understand the instructions.
- Examine that the product is in good condition. If it is necessary, replace damaged parts.
- Clean the product.

### To operate the product

1. Spray the beam with concrete form oil or concrete release agent. This makes it easier to clean the product after operation because the concrete does not attach to the beam.
2. Put the beam at the start of the first section of the concrete surface.

3. Turn the handle to adjust the operation angle of the beam against the concrete surface. Refer to *To adjust the work angle on the handle on page 5*.
  4. Put the handle on your shoulder.
  5. Walk slowly rearward and pull the beam to smooth the surface. The beam removes your shoe prints from the concrete surface.
-

- When you start at the next section of the concrete surface, put 15 cm/5.9 in. (A) of the beam on the smooth concrete surface to make an overlap.

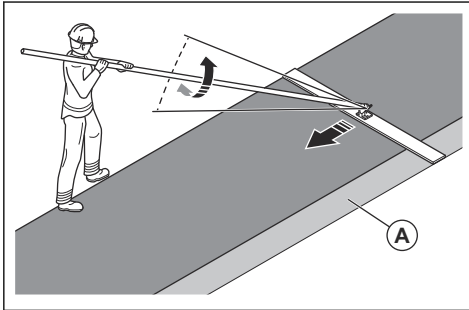

- Put the handle on your shoulder.
- Pull the beam rearward. At the same time turn the handle counterclockwise until the rear edge of the beam is slightly lifted.

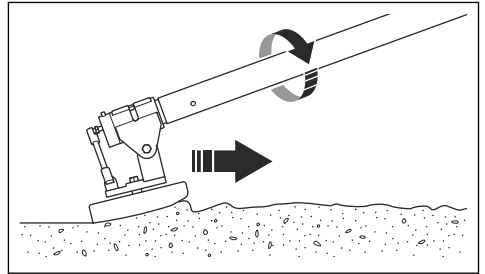

## To adjust the work angle on the handle

- Move the beam forward on the concrete surface. At the same time turn the handle clockwise until the front edge of the beam is slightly lifted.

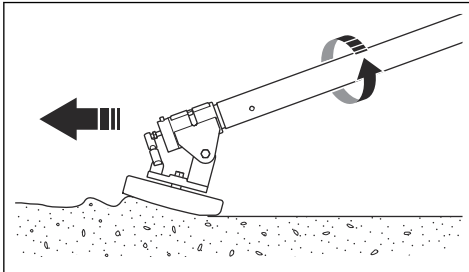

## Maintenance

### Introduction



**WARNING:** Read and understand the safety chapter before you do maintenance on the product.

### Daily maintenance

- Make sure that all the nuts and screws are tight.
- Clean the product.
- Lubricate the swivel.

### To clean the product

- Remove concrete from the surfaces of the product after each operation before the concrete becomes hard.

- Use water and a brush to clean the product.
- Spray the beam with concrete form oil or concrete release agent. This makes it easier to clean the product after the next operation.
- Remove grease and oil from the handle.

### To lubricate the swivel



**CAUTION:** Do not use different types of grease. Refer to *Technical data on page 6* for correct type of grease.

- Lubricate the swivel between the handle and the beam after each time that the product is cleaned.

## Storage and disposal

### Storage

- Clean the product before storage.
- Keep the product in a dry and frost-free area.
- Keep the product in a locked area to prevent access for children or persons that are not approved.

## Disposal of the product

- Obey the local recycling requirements and applicable regulations.

- When the product no longer is used, send it to a Husqvarna dealer or discard it at a recycling location.

---

## Technical data

---

### Technical data

Total weight, kg/lb	7.5/16.5
Handle weight, kg/lb	1.3/2.9
Beam dimensions L*W*H, mm/in.	2000*152*35 / 78.7*5.98*1.37
Handle dimensions (2 pcs) L*W, diameter, mm/in.	1800*2, 44 / 70.86*0.08, 1.73
Working width of the beam, mm/in.	2/6.56
Lubrication	Husqvarna Multi Advanced Grease or equivalent

# Product dimensions

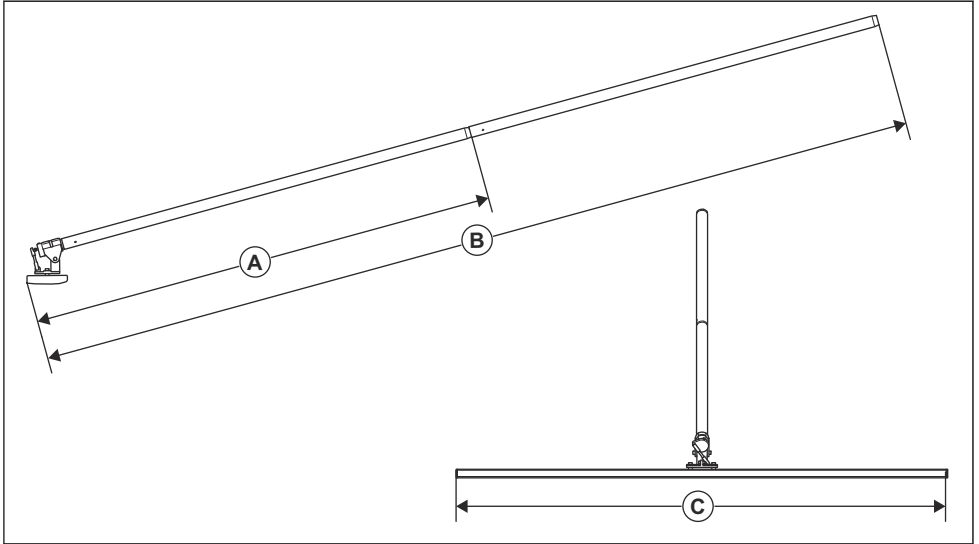

<b>A</b>	Min. length, mm/in.	2200/86.6
<b>B</b>	Max. length, mm/in.	4000/157.5
<b>C</b>	Width, mm/in.	2000/78.7



[www.husqvarnacp.com](http://www.husqvarnacp.com)

Original instructions

1159987-26



2020-04-22