

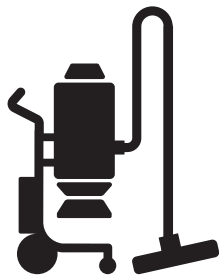

 **Husqvarna**[®]

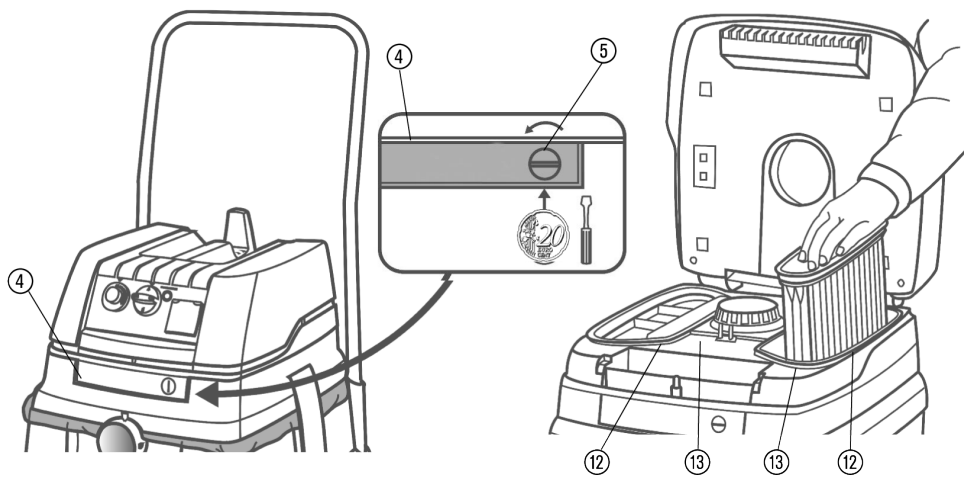

S 11

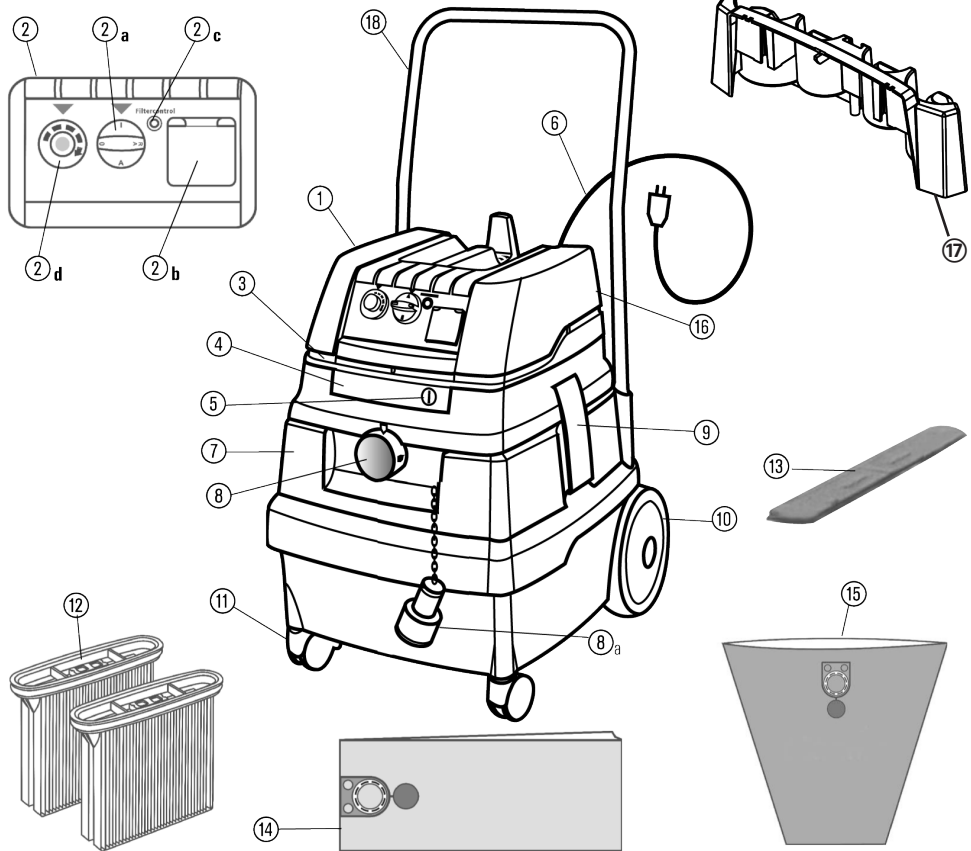

EN Description			
① Top section	③ Cooling air inlet	⑩a Sealing plug with chain	⑭ Fleece filter bag
② Functional plate	④ Latch	⑩ Snap-in locks	⑮ Plastic emptying bag
②a Rotary switch	⑤ Lock	⑪ Wheels	⑯ Suspension for wire basket
②b Power socket for electric tools	⑥ Connecting line	⑫ Steering castors	⑰ Accessories box *
②c Volume flow display (Fill level indicator)	⑦ Container	⑬ Filter cassettes	⑱ Driving handle *
②d Speed control	⑧ Suction opening	⑳ Motor protection filter	* dependig on model

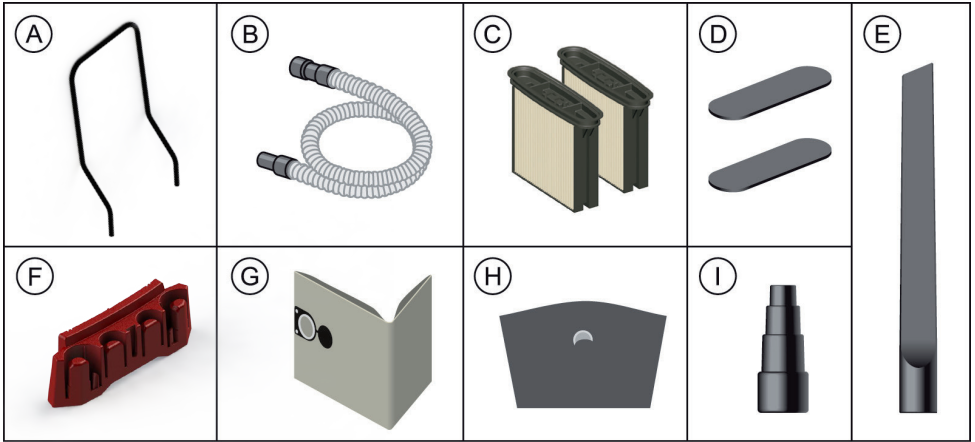

EN Description

- Ⓐ Driving handle
- Ⓑ Suction hose
- Ⓒ Folding filter cartridges
- Ⓓ Motor protection filter
- Ⓔ crevice nozzle
- Ⓕ Accessory storage
- Ⓖ Fleece filter bag
- Ⓗ PE emptying and disposal bag
- Ⓘ Reducer

English

1 Explanation of symbols and signs used

Symbol / Signal word	Description
	This is the warning symbol. It warns against possible risk of injury. Follow all instructions which are marked with this sign to avoid injury or death. The warning symbol always appears in association with the signal words DANGER , WARNING and CAUTION .
DANGER!	Identifies a hazard with a high degree of risk which will cause death or serious injury if not avoided.
WARNING!	Identifies a hazard with a medium degree of risk which could cause death or serious injury if not avoided.
CAUTION!	Identifies a hazard with a low degree of risk which could cause minor or moderate injury if not avoided.
NOTE	Identifies advice or instructions to simplify work and to ensure safe operation.
△	Identifies a requirement which needs to be met before an action is taken.
▶	Identifies steps to be taken one after the other by the user.
↳	Identifies the results of an action.

2 Important safety information

| WARNING!

Danger of suffocation! Do not allow children to play with packaging material, e.g. plastic bags.

Do not climb onto or sit on the vacuum cleaner.

Risk of falling when working on stairs. Pay attention to standing safely.

Do not pull the mains connection cable and suction hose over sharp edges, do not bend it or clamp it.

The mains connection cable and suction hose always must be routed in such a way that no one can trip over it.

If any foam or liquid is discharged, immediately switch off the vacuum cleaner.

Always keep the inside of the lid dry.

Do not use the vacuum cleaner including accessories in the following cases:

- Mains connection cable or extension cable is defective or showing cracks
- There is visible damage to the vacuum cleaner, e.g. cracks in the housing
- If you suspect an invisible defect, e.g. after a fall

| DANGER!

Risk of explosion and fire! Do not run the vacuum cleaner in a potentially explosive environment.

Keep away the vacuum cleaner from flammable gases and substances.

| DANGER!

Risk of explosion and fire! Do not use the vacuum cleaner to vacuum up the following:

- flammable or explosive solvents
- materials soaked in solvents
- potentially explosive dusts
- liquids such as petrol, oil, alcohol, diluents
- materials hotter than 60 °C

I WARNING!

Improperly repaired devices pose a hazard for the user. Only have repairs carried out by experts, e.g. the customer service. Only use original accessories and spare parts.

I WARNING!

Only use the socket on the vacuum cleaner for the purposes specified in the operating instructions.
In case of any inappropriate usage, improper operation or repair, the producer shall be exempt from liability.
Do not use damaged extension cables.
If the mains connection cable of the vacuum cleaner is damaged, it must be replaced by a special mains connection cable, which is available from the manufacturer or its customer service.
Never allow electrical brushes to come into contact with the mains connection cable.
The voltage on the rating plate must match the mains voltage.
Switch off the vacuum cleaner and disconnect the mains plug after use and before maintenance.
When unplugging, only pull on the mains plug and not on the mains connection cable.
Never touch the mains plug with wet hands.
Only connect the vacuum cleaner to a sufficiently protected electric socket.
Do not open the vacuum cleaner outdoors in the rain or during a thunderstorm.
Store the vacuum cleaner dry and indoors, protected from frost.

I WARNING!

Dust-removing machines are tested according to DIN EN 60335-2-69 and divided into dust classes.
Vacuum cleaners for dust class **L** are suitable for vacuuming/sucking up dry, non flammable dusts that are hazardous to health with workplace exposure limits (OEL) > 1 mg/m³.
Vacuum cleaners for dust class **M** are suitable for vacuuming/sucking up dry, non-flammable dusts, non-flammable liquids, wood dusts and hazardous dusts with workplace exposure limits ≥ 0.1 mg/m³.
Vacuum cleaners for dust class **H** are suitable for vacuuming/sucking up dry, non-flammable dusts, carcinogenic and pathogenic particles as well as non-flammable liquids, wood dusts and toxic dusts with workplace exposure limits < 0.1 mg/m³.

I WARNING!

Vacuum cleaners for dust class **H-asbestos** are suitable for vacuuming and extracting dust containing asbestos. Observe national regulations for operation and maintenance of asbestos removal tools.

I WARNING!

The machine may not be used by persons (including children) who have reduced physical, sensory or mental capabilities or who are inexperienced or lack the knowledge of how to use the machine.
Children must be supervised to ensure that they do not play with the device.
Do not point nozzle, tube or hose at people or animals.

I WARNING!

Only use the brushes supplied with the vacuum cleaner or those specified in the operating instructions.
Using other brushes can compromise safety.
When being used in food processing businesses: Immediately clean the vacuum cleaner after use and disinfect it to avoid microbial contamination.
Do not use any steam jets or high-pressure cleaners for cleaning.
Only operate the vacuum cleaner under supervision.
Disconnect the vacuum cleaner from the mains in the event of a longer work interruption.
Do not clean filter cartridges using compressed air.

Read the operating manual carefully before starting to use the vacuum cleaner. The operating manual provides important instructions for safety, commissioning, operation, maintenance and care. Keep the operating manual in a safe place and, in case you sell the unit, hand it on to the next owner.

The manufacturer reserves the right to carry out modifications to the design and equipment.

Do not perform any other work than described in this manual.



This machine is intended for commercial use, for example, in hotels, schools, hospitals, factories, shops, offices and in the rental business.

When unpacking, check for completeness and transport damage.

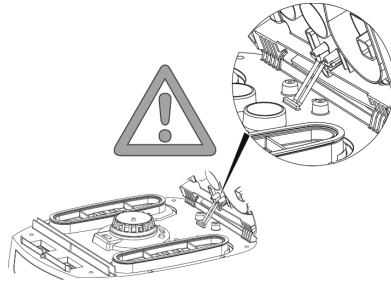
Before use, the operators should be provided with information, instructions and training for the use of the vacuum cleaner and the substances that it is to be used for, including the safe procedure for the removal of the gathered material.



3 Display and control elements

Switch position	Function	Description
0	Vacuum cleaner is switched off	- Plug socket under voltage
I	Vacuum cleaner is running	- Plug socket under voltage - Automatic filter cleaning function off
A	Standby mode for ON/OFF automatic mode	- Plug socket under voltage - The vacuum cleaner is switched on and off via the connected electrical/compressed air tool* at the plug socket
RA	Standby mode for ON/OFF automatic mode	- Standby mode like >A< plus automatic filter cleaning
	Automatic filter cleaning function	- Filter cleaning is performed automatically during the next working break when the minimum volume flow level is reached (switch setting RA)
	Fill level indicator *	- When the container is full and/or there is a blockage in the suction hose, the full indicator lights up. On the M and H vacuum cleaners, an acoustic signal is also emitted
	Setting the suction hose diameter *	- On M-/H-/H-asbestos vacuum cleaners for volume flow monitoring, to trigger an audible warning signal if the air speed falls below 20 m/s
	Setting the motor speed*	- Adjust the suction power with the speed control

* depending on model

4 Commissioning

4.1 Before every use

Make sure that the following conditions are met:

- △ Vacuum cleaner, mains cable, suction hose and accessories are not damaged.
- △ All filters have been inserted and are not damaged.

4.2 Switching on and off

The plug socket on the vacuum cleaner remains always under voltage, regardless of the main switch position.

! WARNING!

Danger of injury by automatically starting power tool!

- ▶ Switch off power tool or pneumatic tool before connecting to the vacuum cleaner.

NOTE

With switch in position >0<, the plug socket on the vacuum cleaner can be used as an extension cable.

I **Power consumption:** vacuum cleaner + connected power tool (max. 2000 W) max. 16 A.

4.2.2 Switching on the vacuum cleaner

Functions see „3 Display and control elements“ on page 7.

- ▶ Insert plug into plug socket.
- ▶ Set switch to position >I<.
 - ↳ Vacuum cleaner starts immediately.

or:

- ▶ Set switch to position >A< or >RA<.
 - ↳ Vacuum cleaner is in standby mode for power tools.

4.2.3 Setting the suction hose diameter*

- ▶ Set suction hose diameter at the switch.

! CAUTION!

Selector switch for minimum air volume flow signal (horn and light) on vacuum cleaners with dust classes „M“ and „H“
In the modes >RA< and >I< the following setting is made, depending on the diameter of the hose:

Selector switch for suction hose inner diameter	Volume air flow
∅ 35 mm	70 l/s
∅ 27 mm	41 l/s
∅ 21 mm	25 l/s

The speed can be adjusted individually after setting the hose diameter.

4.2.4 Adjusting the suction power*

- ▶ Adjust motor speed on the switch.
or

- ▶ Set auxiliary air slide on the handle tube.

4.2.5 Switching off the vacuum cleaner

- ▶ Set switch to position >0<.
 - ↳ Vacuum cleaner is switched off.
- ▶ After switching off, pull the mains plug out.
- ▶ Roll up mains connection cable.
- ▶ Store the mains connection cable on the cable hook.
- ▶ Store the suction tube by inserting it into the accessories holder* on the container rear wall.
- ▶ Put the suction hose ends together so that no dirt particles leak out.
- ▶ Remove Power tool.

5 Operating modes

5.1 Sucking up dry materials

- ▶ Only use a dry filter, vacuum cleaner and accessories, so that the dust does not stick and or cake.
- ▶ When vacuuming soot, cement, plaster or similar dusts: Insert a PE disposal bag in the dirt container.
- ▶ Always use disposal bags in combination with folded filter cartridges.

NOTE

M, H and H-asbestos class vacuum cleaners should be preferably used as vacuum cleaners for dry dusts.

5.2 Sucking up liquids

! WARNING!

Electrical shock hazard!

- ▶ If any foam or liquid is discharged, immediately switch off the vacuum cleaner.
- ▶ Empty dirt container and folded filter cartridge.

NOTE

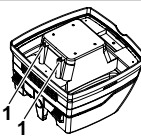

Regularly clean the water level sensors (1) and inspect for signs of damage.

- ▶ Vacuum cleaning without fleece filter bags.
The folded filter cartridge designed for wet vacuum cleaning.
The built-in sensor switches the motor off when the container is full. The handling of the vacuum cleaner can be compromised by a full container.
- ▶ Empty container (see „7 Emptying the container“ on page 9).

NOTE

If the vacuum cleaner is not switched off, the re-start protection remains effective. The vacuum cleaner is ready for operation only after the unit has been switched off and switched on again.

- ▶ Remove the suction hose from the liquid before emptying.
- ▶ After switching off, a small quantity of water can flow back out of the hose, as a result of the high suction level and the favourable flow condition in the container.
- ▶ After wet vacuum cleaning insert dry filters for picking up dry dust.

NOTE

When changing frequently between dry and wet vacuum cleaning, use a second set of filters, preferably polyester folded filter cartridges.

5.3 Sucking up asbestos-containing substances

Only vacuum cleaners of dust class H-asbestos may be used for vacuuming asbestos-containing substances.

- ▶ Only work with a dry filter, vacuum cleaner and accessories to prevent dust from sticking and becoming incrustated.
- ▶ For sucking up asbestos-containing substances: Insert the PE emptying bag or fleece filter bag into the dirt container.
- ▶ Always use filter bags in conjunction with folded filter cartridges.

NOTE

H-asbestos class vacuum cleaners should be preferably used as vacuum cleaners for dry dusts.

! WARNING!

Health hazard !

Asbestos fibres in the air.

- ▶ Supply the work area with sufficient outside air (fresh air).
- ▶ Guide or clean extracted air in such a way that asbestos fibres do not get into the breathing air of other persons.
- ▶ When filtering the extracted air, transport any dust in dust-tight containers.
- ▶ Do not decant dust.

If there is a possibility of asbestos fibres becoming free:

- ▶ Absorb asbestos fibres at the outlet or point of origin.
- ▶ Then dispose of asbestos fibres in accordance with the state of the art without any danger to persons or the environment.

If complete absorption of asbestos fibres is not possible:

- ▶ Take additional ventilation measures in accordance with the state of the art.

After completion of the work:

- ▶ Carefully clean tools, including suction tubes and work equipment.
- ▶ Carefully clean the working area.
- ▶ Moisten and properly remove objects contaminated with asbestos fibres that cannot be cleaned.

After cleaning:

- ▶ Ventilate the working area sufficiently.

6 Permanent filter cleaning

The vacuum cleaner is fitted with an electromagnetic filter cleaning system, which can be used to clean any attached dust from the filter cartridges.

Filter cleaning is performed automatically during the next working break when the minimum volume flow level is reached (switch setting >RA<).

7 Emptying the container

NOTE

Only permitted for dust with workplace exposure limits > 1 mg/m³.

- ▶ Switch off the vacuum cleaner, pull out the mains plug.
- ▶ Open the latches.
- ▶ Remove the cover and suction hose from the container.
- ▶ Empty the container by pouring out.

7.1 Dispose of the fleece filter bag

- ▶ Switch off vacuum cleaner.
- ▶ Disconnect mains plug.
- ▶ Wear appropriate breathing mask.
- ▶ Remove suction hose.
- ▶ Close off intake socket with cap.
- ▶ Open side latches.
- ▶ Remove top section.
- ▶ Carefully pull the flange off the intake socket and close off the flange.
- ▶ Dispose of gathered material in accordance with legal requirements.

7.2 Dispose of the PE emptying and disposal bag

- ▶ Set switch to position >RA<.
 - ↳ Folded filter cartridges are cleaned automatically.
 - ↳ Residual dust in the filters falls into the bag.
- ▶ Switch off vacuum cleaner.
- ▶ Disconnect mains plug.
- ▶ Wear appropriate breathing mask.
- ▶ Remove suction hose.
- ▶ Close off intake socket with cap.
- ▶ Open side latches.
- ▶ Carefully close the PE emptying and disposal bag with the enclosed sealing tape.
- ▶ Carefully pull the flange off the intake socket and close off the flange.
- ▶ Carefully remove the PE emptying and disposal bag from the container.

* depending on model

- ▶ Dispose of gathered material in accordance with legal requirements.

7.3 Insert fleece filter bag

NOTE

Only use fleece filter bags for dry vacuum cleaning.

- ▶ Slide the flange completely over the intake socket.

NOTE

Operating the rotary slide

- ▶ Turn the red rotary slide inside to position CLOSE to the stop on the marker ▲.

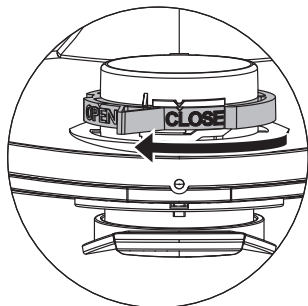

7.4 Insert PE emptying and disposal bag*

NOTE

Only the vacuum cleaners class **M** and **H** with special containers and rotary slider in the suction aperture of types IS/ISC ARM, IS/ISC ARH and IS/ISC ARH-ASBEST are suitable for the use of PE Emptying and disposal bags.

NOTE

Operating the rotary slide

- ▶ Turn the red rotary slide inside to position OPEN to the stop on the marker ▲.
- ▶ Slide the flange completely over the intake socket.
- ▶ Place the upper bag opening over the container rim.

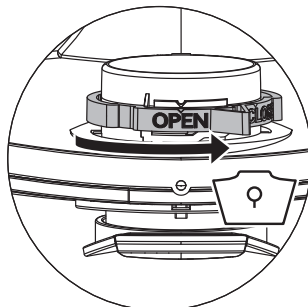

8 Changing the filter

8.1 Changing the folded filter cartridges

- ▶ Clean the filter cartridges before changing them.
- ▶ Turn the lock on the latch through 90° in a counter-clockwise direction with a coin or similar object and push the latch to the rear.
- ▶ Fold up the cover.
- ▶ Immediately isolate the folded filter cartridges that you have removed in a dust-tight plastic bag and dispose of properly in accordance with the requirements.
- ▶ Insert new folded filter cartridges.
- ▶ Lift the locking bracket up, fold down the cover and click in place with light pressure.

9 Changing the motor protection filter

NOTE

If motor protection filter is contaminated, this indicates defective filter cartridges.

- ▶ Replace folded filter cartridges.
- ▶ Replace motor protection filter or wash the motor protection filter under flowing water, dry and re-insert.

10 Transport

- ▶ Remove suction hose.
- ▶ Close off intake socket with cap.
- ▶ Securely fix the motor head to the container.
- ▶ Close the side latches.
- ▶ Place the accessories in a suitable plastic bag and seal the plastic bag or place it in the tool storage compartment.
- ▶ Put the suction hose ends together so that no dirt particles leak out.
- ▶ Place the hose around the vacuum cleaner and clamp onto the handle.

11 Maintenance

NOTE

Switch off the vacuum cleaner and pull out the mains plug before carrying out any maintenance work.

For maintenance by the user, the vacuum cleaner must be

- dismantled,
- cleaned and
- maintained,

as far as possible without creating any danger to the maintenance personnel or other.

Precautionary measures

Suitable precautionary measures include:

- Cleaning before dismantling
- Provision of local filtered positive ventilation where the vacuum cleaner is to be dismantled
- Cleaning of the maintenance area
- Suitable personal protection equipment

Precautionary measures with vacuum cleaners class H and M

The outside of the vacuum cleaner should be cleaned by dust extraction procedures and wiped down, or should be treated with a sealing agent before being removed from the hazardous area. All parts of the vacuum cleaner must be considered to be contaminated when they are removed from the hazardous area, and suitable handling must be used to prevent dust distribution.

Contaminated items

When carrying out maintenance or repair work, all contaminated items which have not been adequately cleaned, must be disposed of. Such items must be disposed of in impermeable bags in accordance with the applicable regulations concerning the disposal of such waste.

11.1 Testing the effectiveness of the vacuum cleaner

At least once a year, the manufacturer or an instructed person must perform a technical inspection including filters, air tightness of the vacuum cleaner, and control mechanisms.

In addition, the effectiveness of the vacuum cleaners with dust class H and H-asbestos must be checked at least once a year or more frequently. The test method, which can be used for demonstrating the effectiveness of the device, is defined in EN 60335-2-69 AA.22.201.2. If the test is not passed, it must be repeated with a new main filter.

There must be an adequate air exchange rate L in the room if the exhaust air returns to the room. Observe national regulations.

If the suction power of the vacuum cleaner is reduced and the cleaning of the filter cartridges is no longer sufficient (assuming that tank is emptied and fleece filter bag is replaced), it is necessary to replace the folded filter cartridges (see „8.1 Changing the folded filter cartridges“ on page 10).

12 Cleaning

NOTE

Acids, acetone and solvents can damage parts of the vacuum cleaner.

- ▶ Clean container and accessories with water.
- ▶ Wipe the top section with a damp cloth.
- ▶ Allow the container and accessories to dry.

13 Repair

! WARNING!

Improperly repaired vacuum cleaners pose a hazard for the user!

- ▶ Have repairs carried out by qualified personnel only, e.g. the customer service.

14 Troubleshooting and repair

NOTE

Malfunions cannot always be traced back to defects in the vacuum cleaner.

Fault	Cause	Remedy
Suction power drops	Filter dirty	Clean
	Filter bag full	Change
	Container full	Empty
	Motor protection filter blocked	Clean
	Nozzle, tube or hose blocked	Clean
Vacuum cleaner does not start	Mains plug not in socket	Plug mains plug into socket
	No mains voltage	Check fuse
	Mains connection cable defective	Replace
	Cover not properly closed	Close
	Water sensor switched off	Empty container
	Vacuum cleaner in standby mode >A< or >RA<	Set switch to > < (see „3 Display and control elements“ on page 7)
The vacuum cleaner does not start when the tool is switched on in the >A< or >RA< mode	Electrical tool not plugged into socket on the vacuum cleaner	Plug mains plug into socket on the vacuum cleaner
	Solenoid valve of pneumatic on-off unit*contaminated	Rinse with alcohol
PE emptying and disposal bag is sucked against the filter	Incorrect position of rotary slide	Set rotary slide to position OPEN ▲ (see „7.4 Insert PE emptying and disposal bag**“ on page 10)
Vacuum cleaner with dust classes M or H : with inserted filter bag, dust is accumulating in the container	Incorrect position of rotary slide	Set rotary slide to position CLOSE ▲ (see „7.3 Insert fleece filter bag“ on page 10)

Do not try anything else, contact customer services.

15 Technical Data

Typ: IS		ISC-H-1425
Voltage	V	220-240
Frequency	Hz	50/60
Rated power	W	1200
Max. power	W	1400
Air flow*	l/s (m ³ /h)	73 (263)
Negative pressure*	hPa/MG	270
Air flow**	l/s (m ³ /h)	42 (151)
Negative pressure**	hPa/SE	235
Noise level	dB(A)	69
Weight	kg	12,1
Dimensions (l x w x h)	cm	45 x 39 x 49

* at the fan

** at the hose

Max. power on vacuum cleaners with plug socket: 1200 W (220-240V~)

Mains connection cable on vacuum cleaners for dust class M, H and H Asbestos with plug socket: H07RN-F 3G1,5

16 Tests and approvals

Electro-technical tests must be carried out in accordance with the accident prevention regulations (DGUV V3) and in accordance with DIN VDE 0701 Part 1 and Part 3. These tests are required in accordance with DIN VDE 0702 at regular intervals and after repair or modification.

The vacuum cleaners are successfully tested in accordance with IEC/EN 60335-2-69.

NOTE

Old equipment contains valuable materials which are designed for re-processing. The vacuum cleaners must **not be thrown away in the normal household waste**, but should be disposed of at a suitable proper collection system, e. g. via your communal disposal location.



17 EU Declaration of conformity

We, Husqvarna AB, SE 561 82 Huskvarna, SWEDEN, Tel. +46 36 146500 declare on our sole responsibility that the product:

Description	Dust Extractor
Brand	HUSQVARNA
Type / Model	S 11
Identification	Serial numbers dating from 2019 and onwards

complies fully with the following EU directives and regulations:

Directive/Regulation	Description
2006/42/EC	"relating to machinery"
2014/30/EU	"relating to electromagnetic compatibility"
2011/65/EU	"relating to restriction of hazardous substances"

and that the following standards and/or technical specifications are applied;

EN ISO 12100:2010

EN 55014-1:2017

EN 55014-2:2015

EN 61000-3-2:2014

EN 61000-3-3:2013

EN 60335-1:2012/A11:2014/AC:2014

EN 60335-2-69:2012

Partille, 2020-04-06



Martin Huber

R&D Director, Concrete Surfaces & Floors
Husqvarna AB, Construction Division
Responsible for technical documentation

18 Circuit Breaker for vacuum cleaner socket

For Australia & New Zealand version only

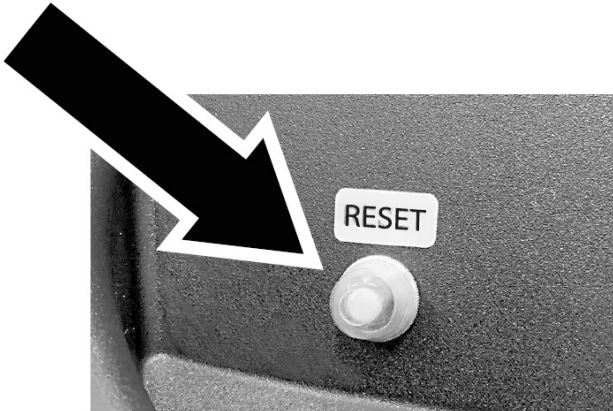

- The fuse protects the device socket from overload.
- It triggers if the socket is loaded with excessive current (5A or more) over an extended period of time. The white reset button (see fig.) pops out and disconnects the power supply and the vacuum cleaner's linked automatic power-on function.
- To reset the fuse, wait for a short period of time (approx. 15-30 sec.) before pushing the white reset button (see fig.) back to its original position.

dust class

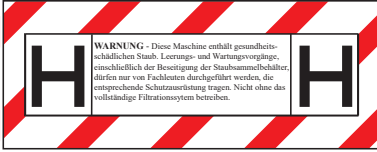

Class H vacuum devices are suitable for aspiration/clearing of dry, non-combustible dusts, carcinogenic and pathogenic particles as well as non-combustible liquids, wood dusts and toxic dusts with workplace limit values of $< 0.1 \text{ mg/m}^3$.

WARNING: This machine contains harmful dust. Emptying and maintenance, including removing the dust collection container, may only be performed by specialist staff who are wearing the appropriate personal protective equipment. Never operate without a complete filtration system.



www.husqvarnacp.com

1142095-28

2020-04-06