



SERVICE MANUAL BMG-735PRO

VERSION 2.4

Index

1. Tools		03
2. Spare parts		04
3. Electric schedules		
E06866	3x 400V / 11kW / frequency drive	24
E06866/UL230	3x 230V / 11kW / frequency drive	33
4. Fault diagnose frequency drive		42



1. Tools

Accessories



<p>E07240-2 DIAMAG ADAPTER PLATE Ø240 MM</p>	<p>BG707321 #18 - 20 BG707322 #30 - 40 BLUE GRINDING WING</p>	<p>BG707311 #18 - 20 BG707312 #30 - 40 BG707313 #60 - 80 BG707314 #120 - 150 GREEN GRINDING WING</p>	<p>BG707301 #18 - 20 BG707302 #30 - 40 BG707303 #60 - 80 BG707304 #120 - 150 RED GRINDING WING</p>	<p>BG707341-2 #30 - 40 BLACK GRINDING WING</p>
-----------------------------------------------------------------	-------------------------------------------------------------------------------------	--------------------------------------------------------------------------------------------------------------------------------------------------	------------------------------------------------------------------------------------------------------------------------------------------------	-----------------------------------------------------------



<p>E10692 DIAMAG ADAPTER PLATE WINGS PCD Ø240 MM</p>	<p>BG200997-1/SET PCD SPLIT WING BG200995-1/SET PCD 1x1 WING</p>	<p>E09580 ROTARY PLATE ONLY Ø240 MM E10240 PLATE Ø240 MM COMPLETE WITH BUSH HAMMER ROLLERS E10240/SW PLATE Ø240 MM COMPLETE WITH STAR WHEELS</p>	<p>E09119-1 BUSH HAMMER ROLLER Ø50 MM BG300109 CUTTER WHEEL Ø50 MM</p>	<p>E09368/FINE VELCRO PLATE Ø240 MM For Polishing pads E09368/COARSE VELCRO PLATE Ø240 MM For Maintenance pads</p>
-----------------------------------------------------------------------------	--------------------------------------------------------------------------------------------	---------------------------------------------------------------------------------------------------------------------------------------------------------------------------------------------------	--------------------------------------------------------------------------------------------------------------	------------------------------------------------------------------------------------------------------------------------------------------------------



<p>BG240001 #40 #1 - orange BG240002 #100 #2 - Black BG240003 #200 #3 - Blue BG240004 #400 #4 - Red BG240005 #800 #5 - White BG240006 #1500 #6 - Yellow BG240007 #3000 #7 - Green POLISHING PADS Ø240 MM</p>

<p>BG240M004 #400#4 BG240M005 #800#5 BG240M006 #1500 #6 BG240M007 #3000 #7 MAINTENANCE PADS Ø240 MM</p>

<p>005014 10 M SUCTION HOSE Ø76 MM</p>



2. Spare parts

Frame complete

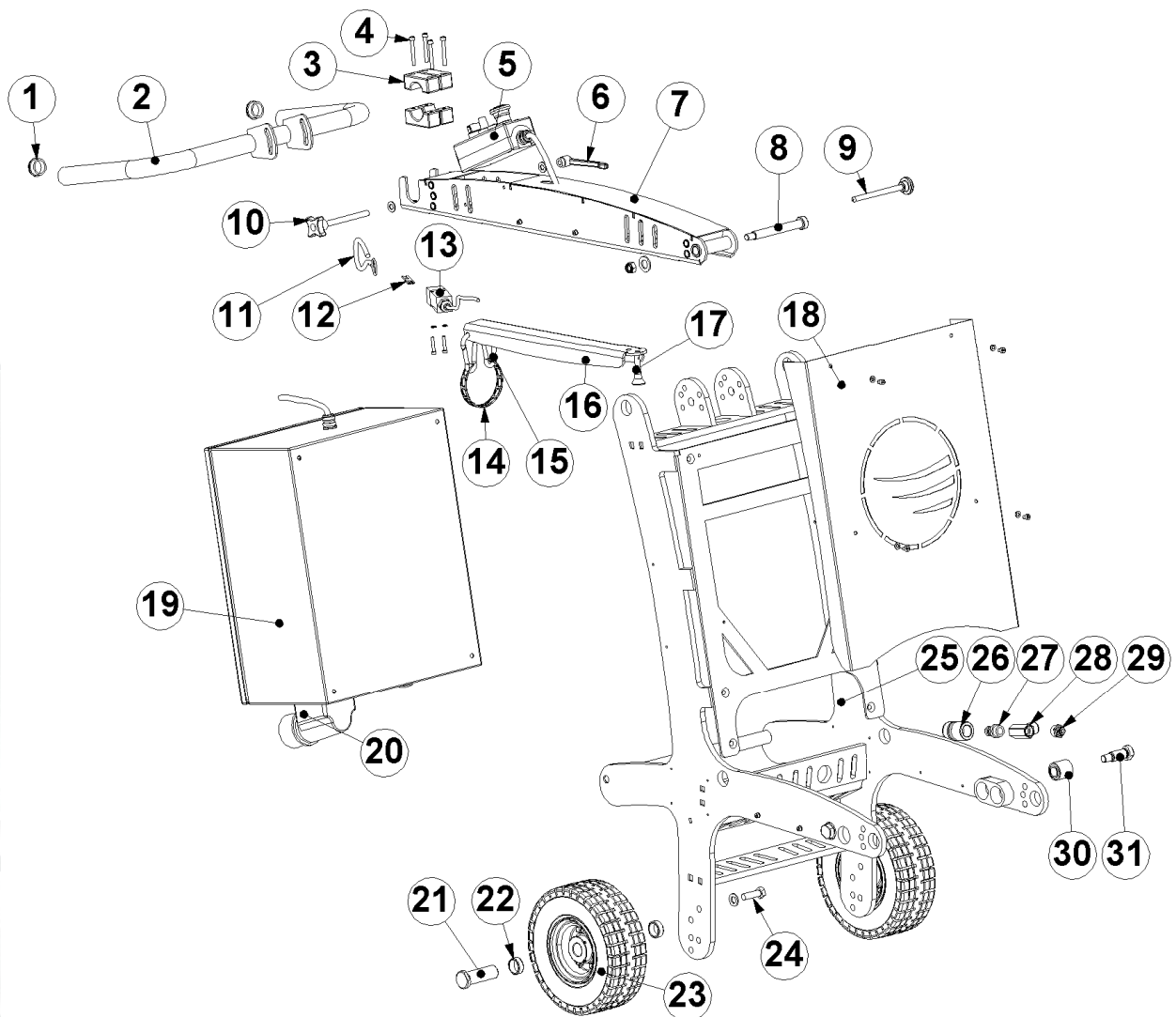



Item	Part number	Description	Remarks	Qty.
1	BE0643	Tube cap round		2
2	E07032/BL	Handle for steer long		1
3	999-9156	Pipe clamp (set)		2
4	BE0191	M6x50 hexagon socket head bolt	DIN 912	4
5	E07882	Operating box complete		1
	E01543	Emergency stop		
	E01318	Start button		
	E01351	Potential meter complete (speed switch)		
	E01323	Left / right switch		
	E05130	Make contact (green)		
	E05131	Brake contact (red)		
6	BE0641	M10 clamp lever		1
7	BG005835	Steer handle		1
8	BE0640	M12 hexagon shoulder screw		1
9	BE0674	Handle locking pin		1
10	E06860	Clamping pin steer		1
11	BG11758	Cord for deadman switch		1
12	BG11759	Key for deadman switch		1
13	BG11760	Deadman switch		1
14	E07008	Chain (11links)		1
15	BE0653	Hook		2
16	E06883	Swing arm for dusthose		1
17	478198	Quick release pin		1
18	BG005838	Cover plate electro box		1
19	BG11916	Electrobox 11kW complete		1
	BG11916/UL	Electrobox 11kW complete 230UL		1
20	E05135	Electrical inlet 3x400V 32A		1
	E05134	Electrical inlet 3x230V 63A		1
21	E06904	Wheel bolt long		2
22	BG11850-1/1	Wheel spacers		4
23	BG11850-1	Wheel		2
24	BE0036	M12x40 hexagon head bolt		2
25	BG005825	Frame		1
26	E06286	Water coupling		1
27	E06285	Waterhose connection		1
28	E06282	Ball valve mini		1
29	E06279	Water reducing coupling		1
30	E01492	Megi bush		2
31	BG11752	Hinge bolt		2
	E06892_BL	735PRO logo blue		2
	E06819	Blastrac logo		4

Machine complete

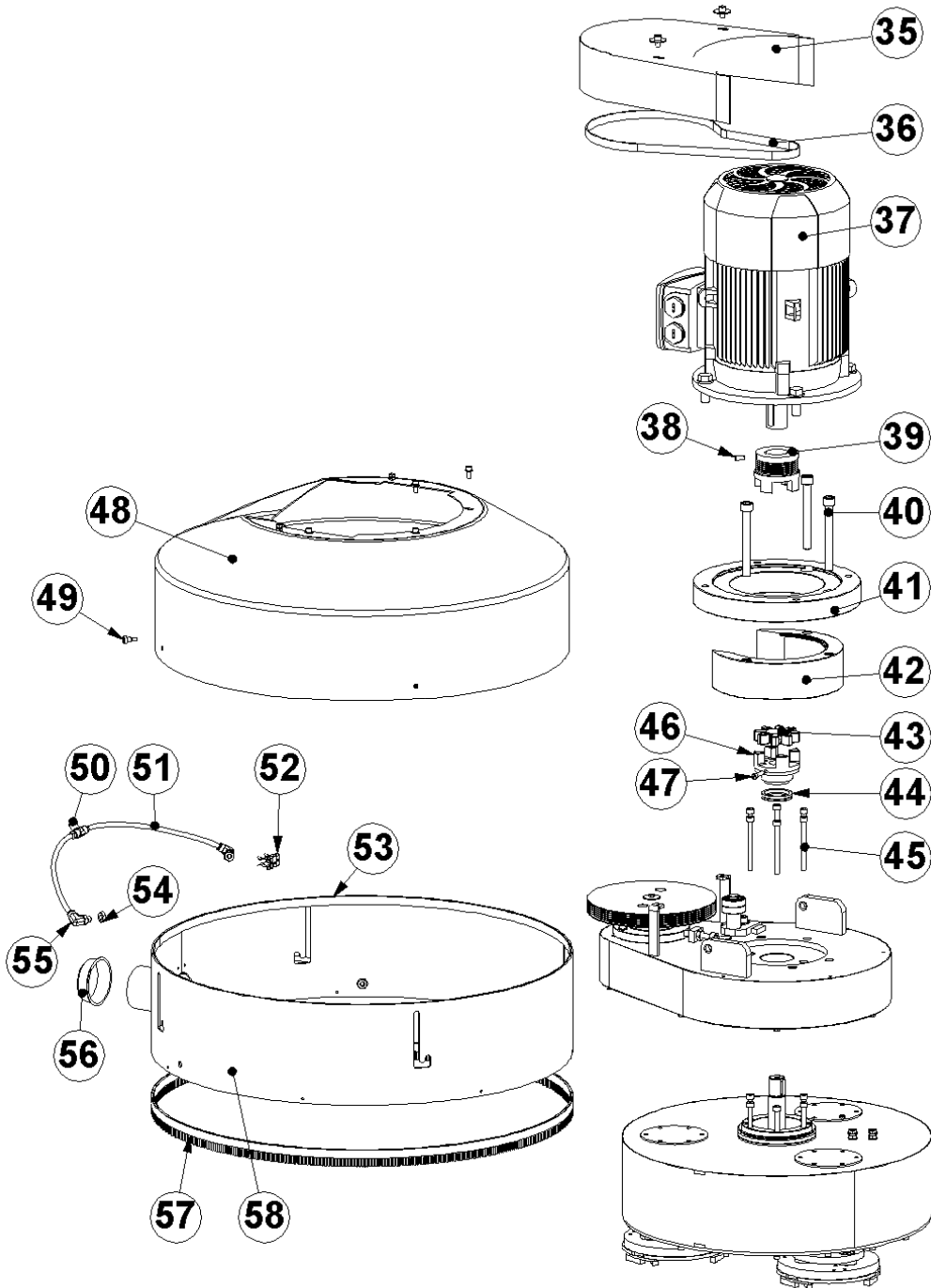



Item	Part number	Description	Remarks	Qty.
35	BG005847	Protection cap		1
36	BG11924	Upper belt		1
37	BG11923-1IE2	Motor 230/400V		1
38	BE0654	M8x16 set screw	DIN 916	4
39	BG007808_2	Coupling upper part		1
40	BE0656	M14x140 hexagon socket head bolt	DIN 912	3
41	BG007810	Flange motor seat		1
42	BG007811	Motor seat		1
43	BG005844	Coupling plastic star		1
44	BG11829	V-seal		1
45	BE0635	M8x110 hexagon socket head bolt	DIN 912	6
46	BG007808_1	Coupling under part		1
47	BE0188	M6x25 hexagon socket head bolt	DIN 912	1
48	BG007339	Protection cover		1
49	BE0655	M6x12 hexagon shoulder screw		4
50	E06281	Water T-coupling		1
51	E06278	Waterhose		1,5m
52	E06276	Pipe clamp		2
53	E06897	Slide strip		2,5m
54	E06293	Nut for knee coupling		2
55	E06280	Water knee coupling		2
56	E04551	Plastic cap		1
57	BG007349	Brush for floating shroud		1
58	BG007355	Floating shroud		1

Upper drive

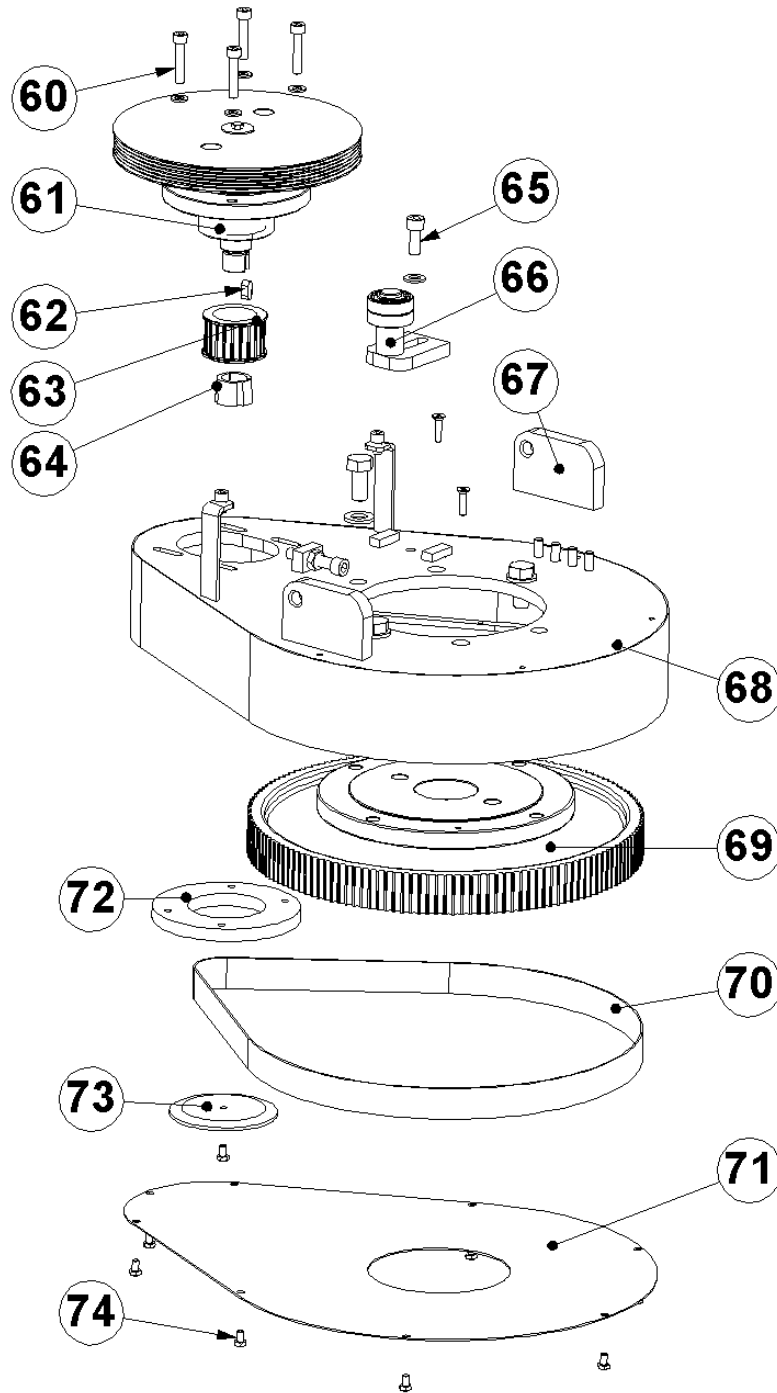



Item	Part number	Description	Remarks	Qty.
60	BE0631	M8x40 hexagon socket head bolt	DIN 7984	4
61	BG005856	Contra pulley		1
62	BE0648	Key 8x7x18	DIN 6885A	1
63	BG005805-1	Pulley		1
64	E01560	Taperlock		1
65	BE0443	M10x25 hexagon socket head bolt		
66	BG005860	Upper tensioner		1
67	BG005813	Holder		2
68	BG005809	Motorplate complete		1
69	BG005857	Centre pulley		1
70	BG11904	Middle belt		1
71	BG005834	Lower plate upper drive		1
72	BG005807	Ring		1
73	BG007804	Flange		1
74	BE0350	M6x10 hexagon head screw		8

Lower drive

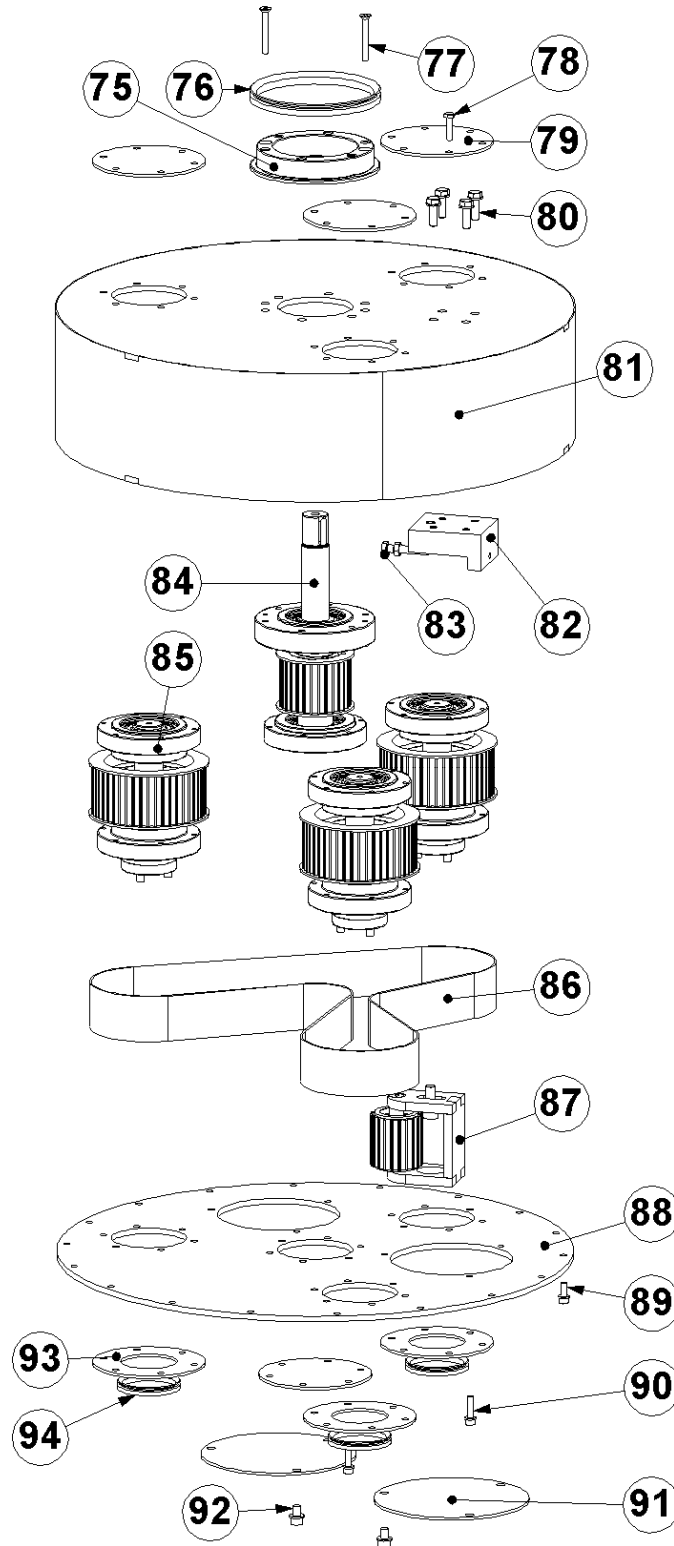



Item	Part number	Description	Remarks	Qty.
75	BG005814	Ring		1
76	BG11849	V-seal		1
77	BE0617	M6x50 countersunk screw	DIN 7991	2
78	BE0051	M6x25 hexagon head bolt	DIN 933	18
79	BG005827	Cover		4
80	BE0030	M8x25 hexagon head bolt	DIN 933	4
81	BG007322	Housing complete		1
82	BG005832-1	Holder		1
83	BE0090	M8x40 hexagon head bolt	DIN 933	1
84	BG005858	Drive pulley		1
85	BG005859	Pulley		3
86	BG11940	Lower belt		1
87	BG005861	Lower tensioner		1
88	BG007324	Lower plate 735PRO		1
89	BE0035	M6x16 hexagon socket head bolt	DIN 912	18
90	BE0188	M6x25 hexagon socket head bolt	DIN 912	24
91	BG007850	Inspection cover		2
92	BE0082	M8x12 hexagon socket head bolt	DIN 912	6
93	BG0005826	Ring		3
94	BG11797	V-seal		3

Contra pulley BG005856

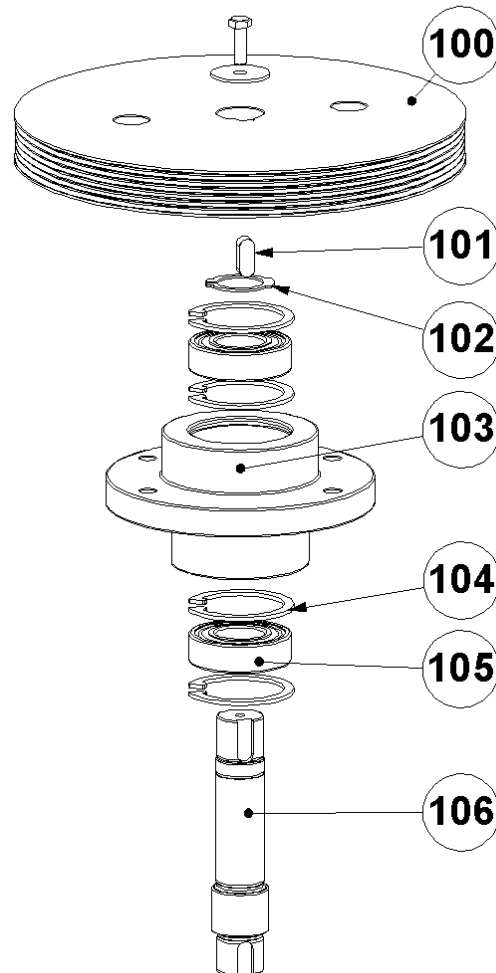

Item	Part number	Description	Remarks	Qty.
100	BG005803	Belt pulley		1
101	BE0109	Key 8x7x20	DIN 6885A	1
102	BE0076	Retaining ring for shaft Ø25	DIN 471	1
103	BG005802	Bearing house		1
104	BE0077	Retaining ring for bore Ø52	DIN 472	4
105	222-2331-E	Bearing		2
106	BG005801	Axle		1

Centre pulley BG005857

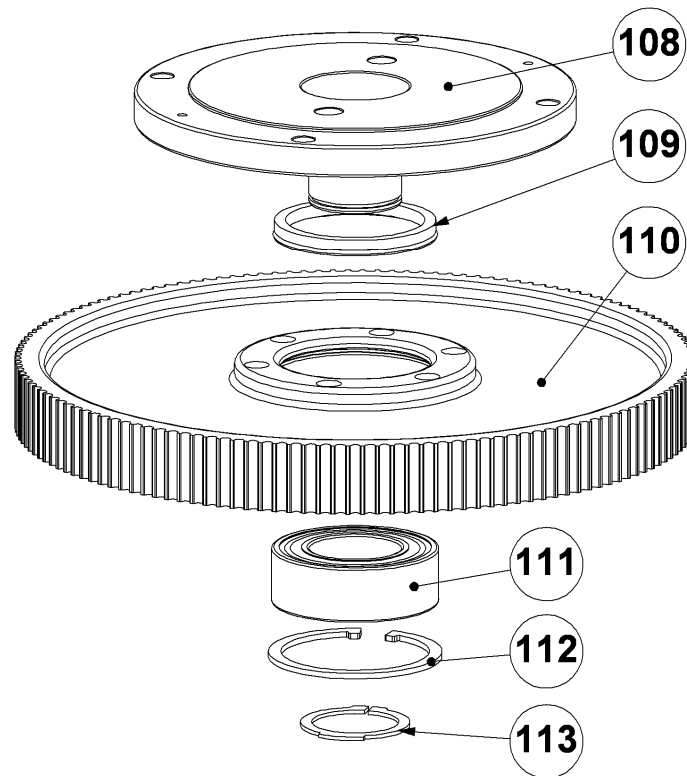

Item	Part number	Description	Remarks	Qty.
108	BG005812	Sprocket		1
109	E03703	V-seal		1
110	BG005806	Pulley		1
111	E01490	Bearing		1
112	E03993	Retaining ring for bore Ø90	DIN 472	1
113	BE0126	Retaining ring for shaft Ø50	DIN 471	1

Drive pulley BG005858

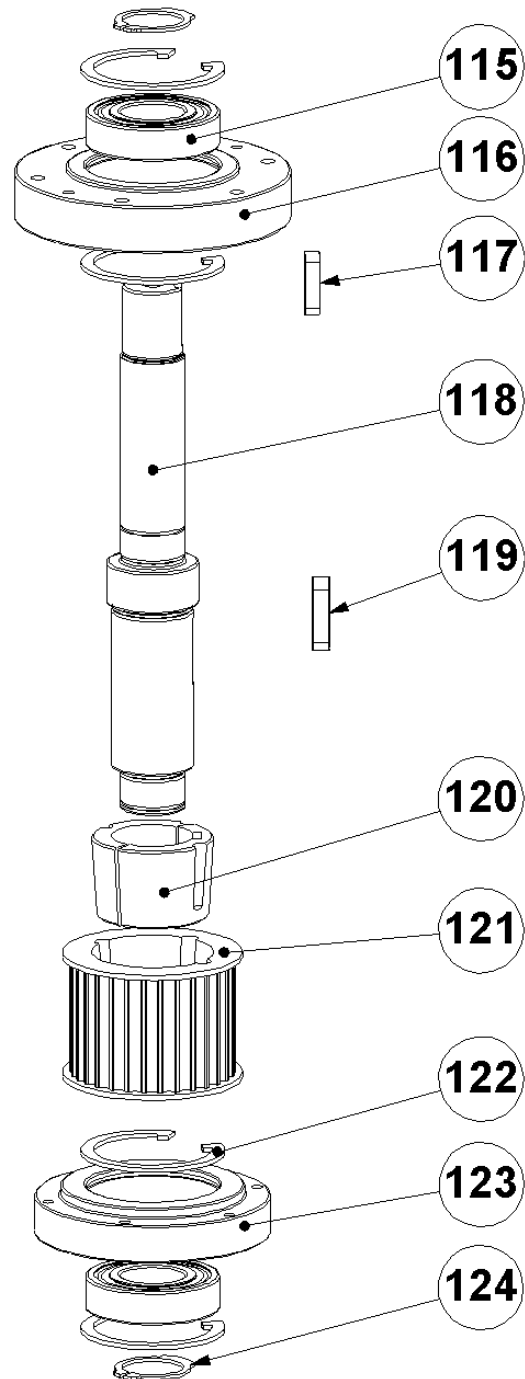



Item	Part number	Description	Remarks	Qty.
115	B20404	Bearing		2
116	BG005815	Bearing house		1
117	BE0256	Key 8x7x30	DIN 6885A	1
118	BG005818	Axle		1
119	BE0269	Key 10x8x32	DIN 6885A	1
120	E00718	Taperlock		1
121	BG005820	Pulley		1
122	E00951	Retaining ring for bore $\varnothing 62$	DIN 472	4
123	BG005821	Bearing house		1
124	B21631	Retaining ring for shaft $\varnothing 30$	DIN 471	2

Pulley (3x) BG005859

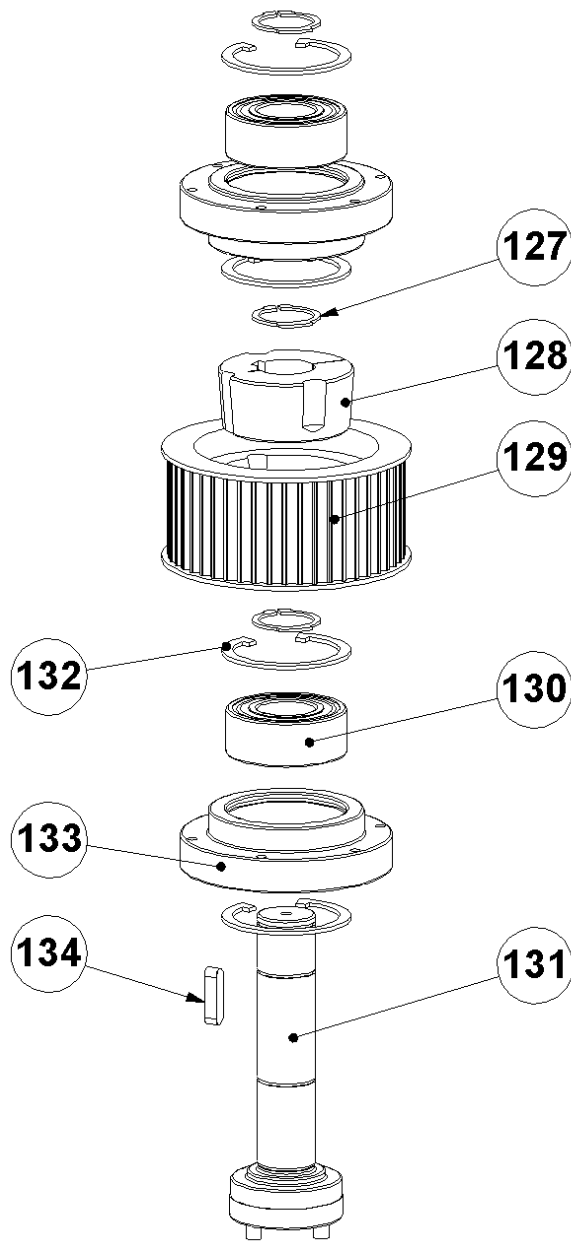

Item	Part number	Description	Remarks	Qty.
127	B21631	Retaining ring for shaft Ø30	DIN 471	3
128	RB100A3-350	Taperlock		1
129	RB165-2	Pulley		1
130	BG11817	Bearing		2
131	BG005816	Axle		1
132	E00951	Retaining ring for bore Ø62	DIN 472	4
133	BG005817	Bearing house		1
134	BE0256	Key 8x7x30	DIN 6885A	1

Upper tensioner BG005860

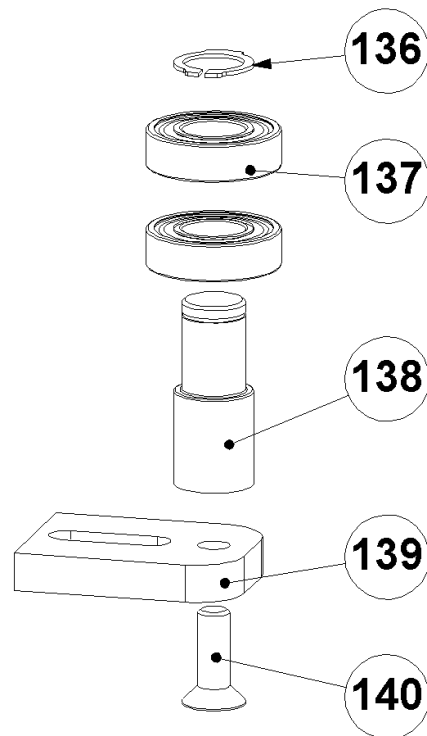

Item	Part number	Description	Remarks	Qty.
136	BE0074	Retaining ring for shaft Ø20	DIN 471	1
137	222-2245	Bearing		2
138	BG005830	Axle for tensioner		1
139	BG005831	Tension plate		1
140	BE0130	M10x25 countersunk screw	DIN 7991	1

Lower tensioner BG005861

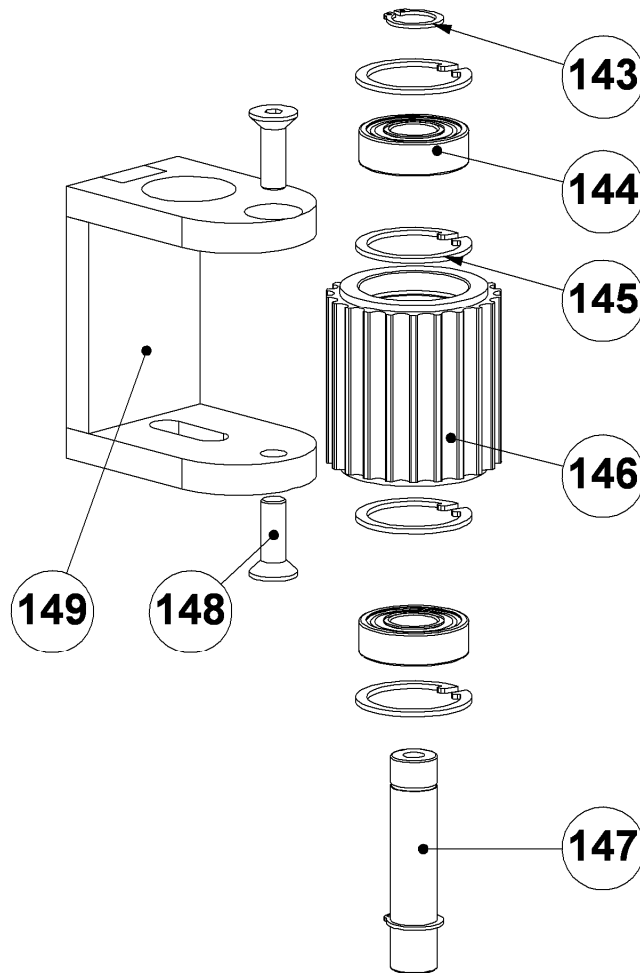

Item	Part number	Description	Remarks	Qty.
143	BE0070	Retaining ring for shaft Ø15	DIN 471	2
144	BG11792	Bearing		2
145	BE0618	Retaining ring for bore Ø35	DIN 472	4
146	BG005836	Pulley		1
147	BG005837	Axle tensioner		1
148	BE0458	M8x25 countersunk screw	DIN 7991	2
149	BG005833	Tensioner		1

Buffer plate for surface preparation (3x)

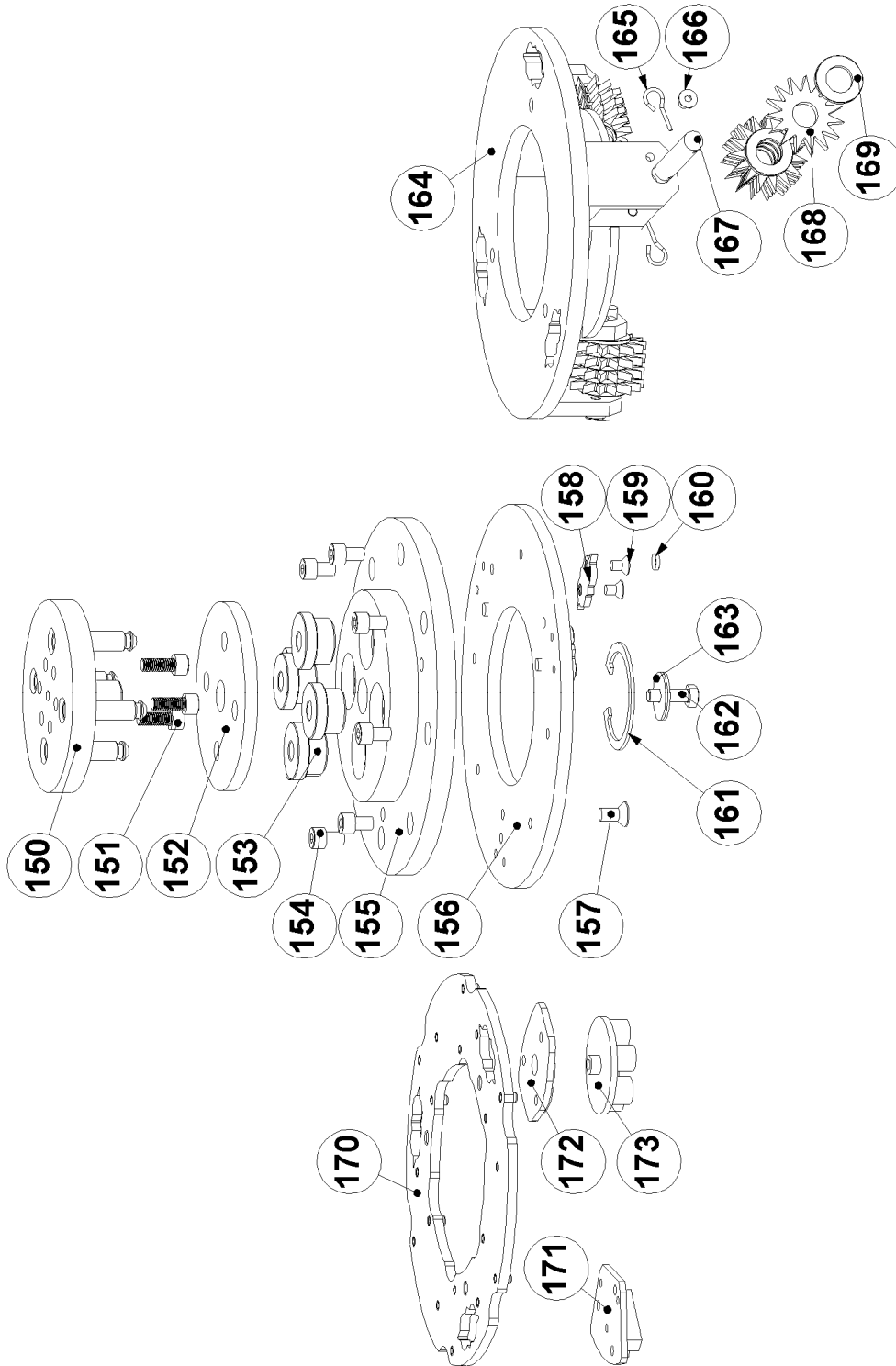

Item	Part number	Description	Remarks	Qty.
153-160	BG240190-1	240mm diamond holder complete		1
156-160	BG2401901-1	240mm diamond holder		1
150	BG11880-HD	Fork		1
151	BE0204 + BE0584	M8x25 hexagon socket head bolt small + M8 spring washer small	DIN 7984 DIN 7980	3
152	BG11879	Buffer disc		1
153	BG11878	Buffer hard		4
154	BE0082	M8x12 hexagon socket head bolt	DIN 912	8
155	BG11877	Magnet plate holder 240mm		1
156	BG2401901-1	Only complete with parts 157 - 160		1
157	BE0456	M8x16 countersunk screw	DIN 7991	3
158	BG11811	Centering star		3
159	BG11810	M6x10 countersunk screw	DIN 7991	6
160	E06446	Magnet		3
161	BE0608	Retaining ring for bore Ø58	DIN 472	1
162	BE0030	M8x25 hexagon head bolt	DIN 933	1
163	BE0314	M8x30x1,5 washer		2
164-169	BG300117	240mm cutter housing complete		1
164	BG300501-1	185mm cutter housing		1
165+166	BG300133	Locking pin & screw		6
167	BG300130	Axle		3
168	BG300109	Cutter		12
169	MPL48	Washer		15
170	E07240	DIAMAG 240mm adapter plate		1
	BG200993-1	Plate for wings 240mm		1
	BG200988-1	Dry polish dot holder 240mm		1
171		DIAMAG grinding wings		3
172	E06447	DIAMAG adapter plate for dots		3
173		Dry polish dots		3

Buffer plate for polishing (3x)

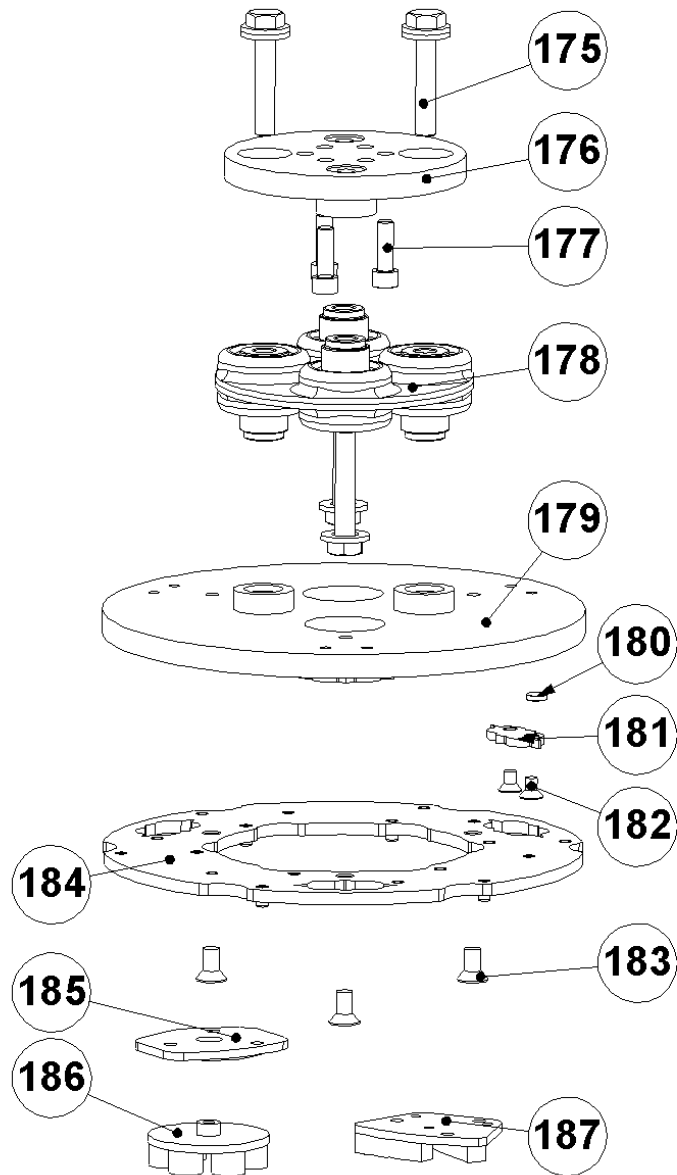



Item	Part number	Description	Remarks	Qty.
175	BE0589	7/16 x 2"½ hexagon UNC bolt		4
176	BG2402001	Flexplate adapter for axle		1
177	BE0012	M8x25 hexagon socket head bolt	DIN 912	3
178	BG400310	Morflex coupling		1
179-182	BG2402002-1	Flexplate diamond holder		1
179	BG24020021-1	Flexplate diamond holder only		1
180	E06446	Magnet		3
181	BG11811	Centering star		3
182	BG11810	M6x10 countersunk screw		6
183	BE0456	M8x16 countersunk screw	DIN 7991	3
184	E07240	DIAMAG 240mm adapter plate		1
	BG200993-1	Plate for wings 240mm		1
	BG200988-1	Dry polish dot holder 240mm		1
185		DIAMAG grinding wings		3
186	E06447	DIAMAG adapter plate for dots		3
187		Dry polish dots		3



3. Electric schedules

E06866 / 3x 400V / 11kW / frequency drive

SYMBOL CODE

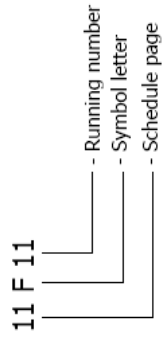

CORE CODE

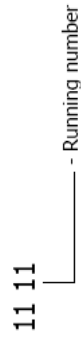

DRAWING NUMBER

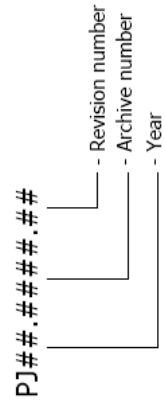

WIRE COLOR

Main Voltage 400V

Phase

- L1
- L2
- L3
- Earth / PE

Colors

- Black
- Black
- Black
- Yellow/Green

Control Voltage

- Plus (24VDC)
- Hook-up wire
- Minus / Ground (24VDC)

- White
- White
- White



	auxiliary contact	hulpcontact		signal lamp		Safety fuse	smelvezigheid
	Power contact	vermogenscontact		hoorn		Fused switch, three-pole	schakelbare schieder
	NO contact, opens with time delay	maakcontact, vertraagd open		apm.meter		Fused disconnect, three-pole	schieder "kubpak"
	NO contact, closes with time delay	maakcontact, vertraagd sluitend		running hour counter		Main switch	hoofdschakelaar
	NC contact, opens with time delay	brekcontact, vertraagd open		transformer		Circuit breaker, single-pole	installeerautomaat 1-pool
	NC contact, closes with time delay	brekcontact, vertraagd sluitend		Contactor coil relay coil		Circuit breaker, two-pole	installeerautomaat 2-pool
	Pushbutton rebound	drukknop terugrend		spool		Circuit breaker, three-pole	installeerautomaat 3-pool
	Pushbutton locking	drukknop blijvend		Spool met opkloververging		Power circuit breaker motor overload switch with switch mechanism	motorbeveiligingsschakelaar
	Rotary switch rebound	draaischakelaar		spool met afkloververging		Valve	elektrisch bedienende klep
	Rotary switch locking	draaischakelaar		Contactor pulse coil relay pulse coil		Resistor with movable contact	regelbare weerstand
	Emergency stop rotary unlock	stopknop met draaibare vrijgave		Tube light		Terminal	riggklem
	Thermostatic switch	thermostaat hygrodraat		Resistor / Heating		Terminal with fuse	riggklem met zekering
	Pressure switch	drukschakelaar		Socket		Rectifier	geleijdrer
	Limit switch	endschakelaar		Current transformer			
	Proximity switch	naderingsschakelaar					

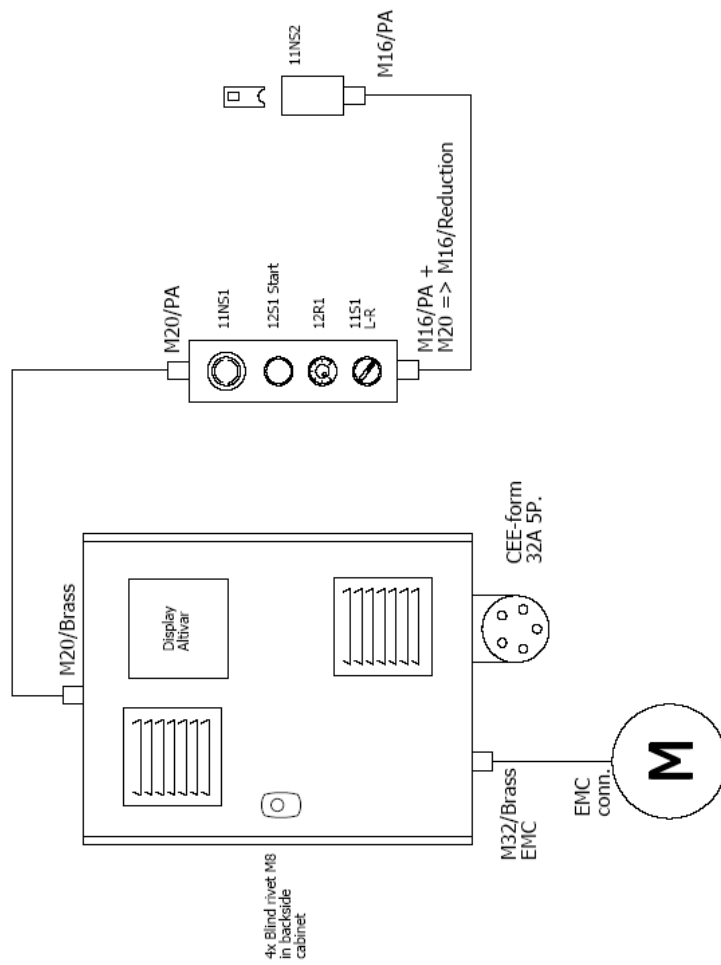
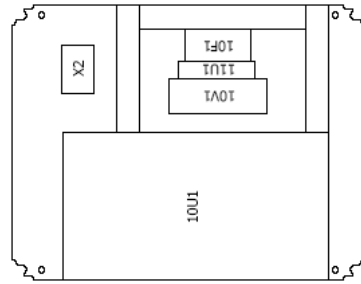

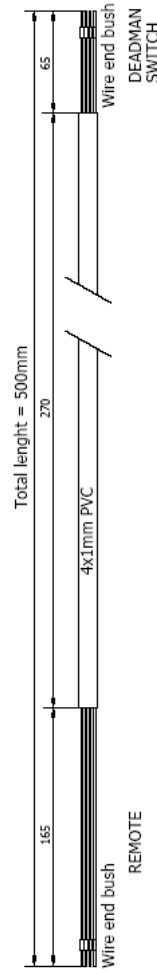
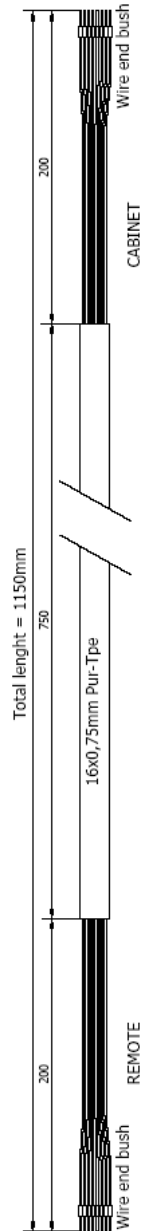
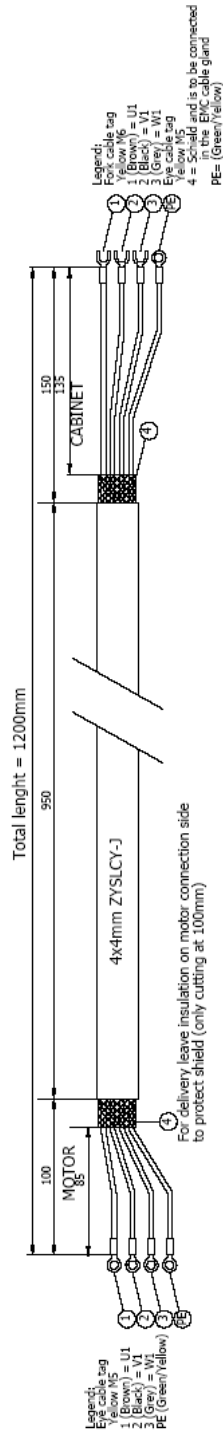

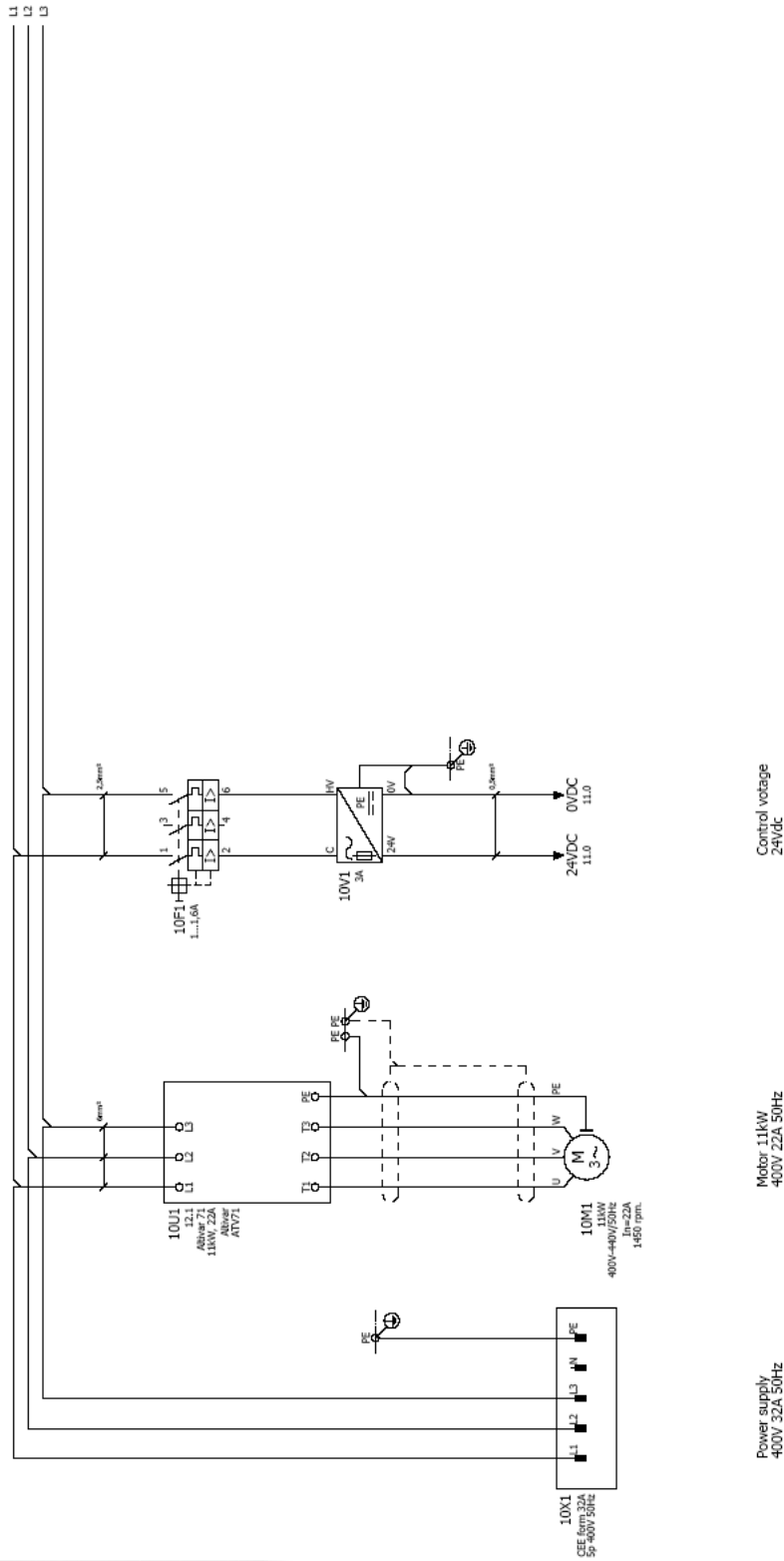

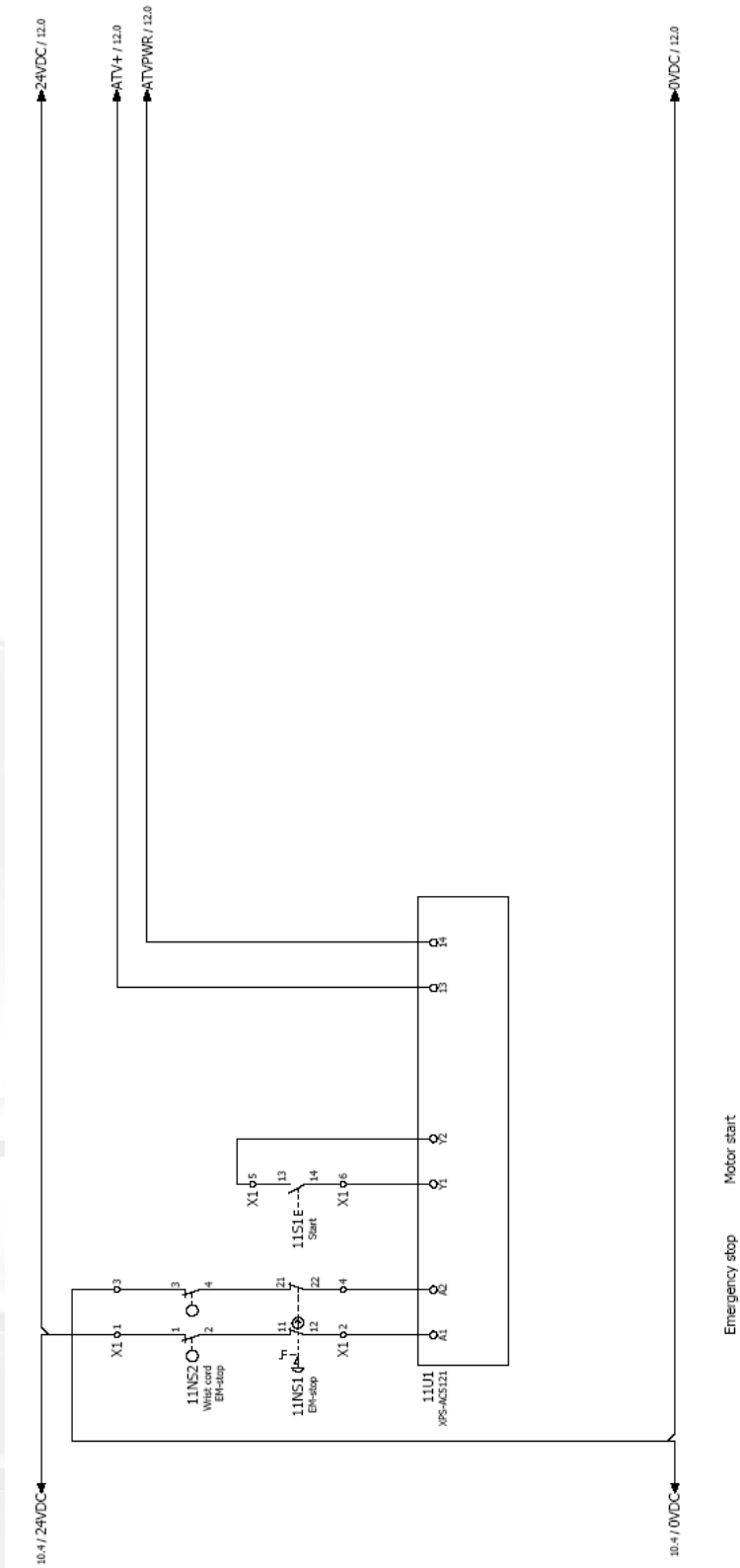

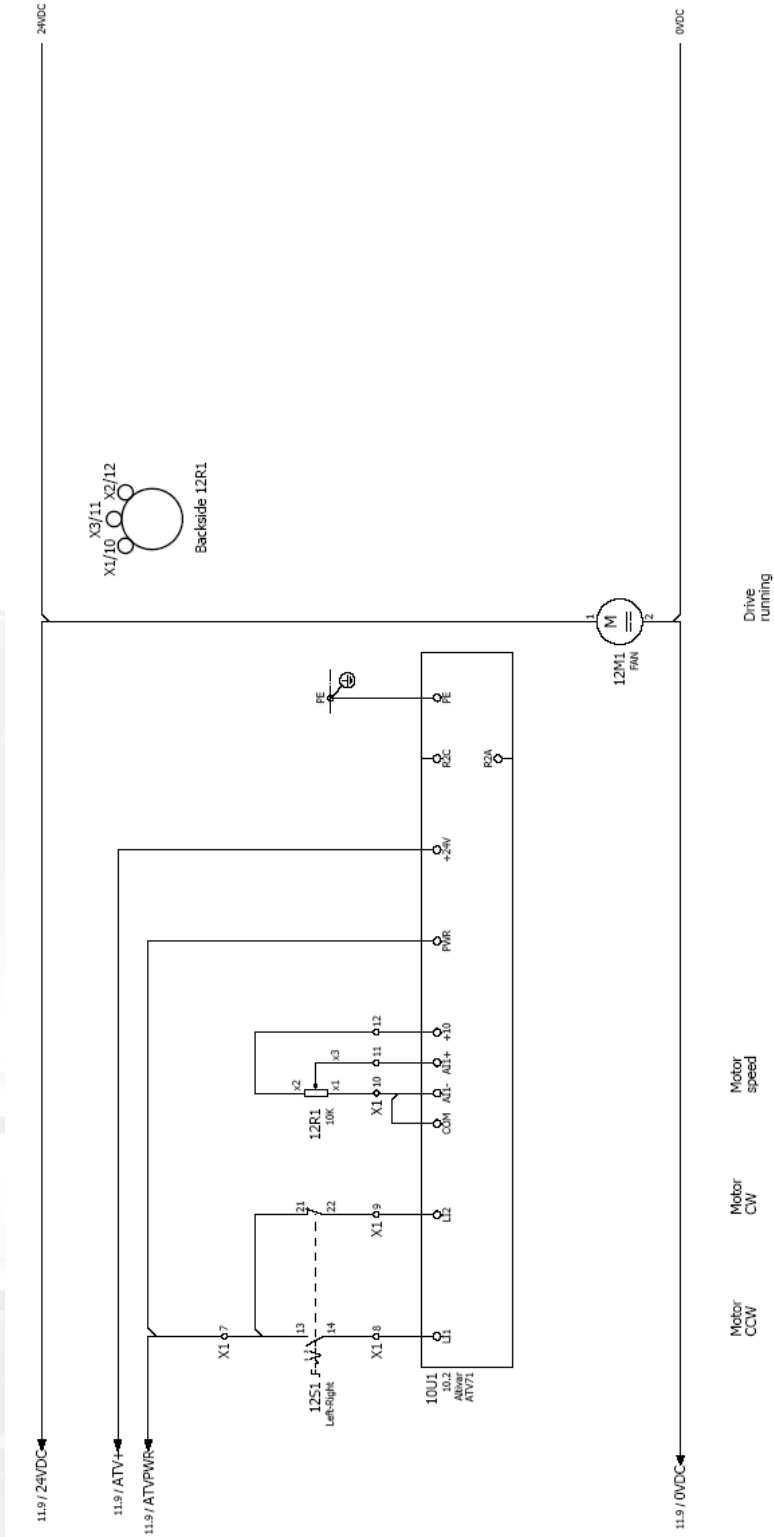



Terminal diagram

function text	Strip X1 Terminal 24Vdc										Cable name		Cable type		Page / column			
	Target designation	Connection point	terminal	jumper	Target designation	Connection point												
Emergency stop		PE	PE	.	1001	PE											12.5	
=	L1NS2	1	1	.	10V11;2M1	24V/1												11.1
=	L1NS1	2	2	.	1001	A1												11.1
=	L1NS2	3	3	.	10V11;2M1	0V/PE-2												11.1
Motor start	L1NS1	4	4	.	1001	A2												11.1
=	L1S1	5	5	.	1001	Y2												11.2
=	L2S1	6	6	.	1001	Y1												11.2
Motor CCW	L2S1	7	7	.	10V11;001	14-PMR												12.1
=	L2S1	8	8	.	1001	U1												12.1
Motor CW	L2S1	9	9	.	1001	L2												12.2
Motor speed	L2R1	10	10	.	1001	A1+												12.2
=	L2R1	11	11	.	1001	A1+												12.3
=	L2R1	12	12	.	1001	*10												12.3



Parts list

device tag	Quantity	designation	Type number	part number
CAB	1	Steel enclosure 500x400x250 with mounting plate 400x350	8724 STEEL	8724
CAB	1	Blind rivet M8x16	Blindrivier M8	POPBC M8x16 # verzinkt
PG	1	Cable gland M20*1.5 Nickel-plated	WARTTEL L-M20*1.5	50.620 M.L.
PG	1	Locknut M20*1.5 Nickel-plated	WARTTELMOER M20	50.220 M.
PG	1	Cable gland M20*1.5	WARTTEL PA M20*1.5	50.620 PA.V035
PG	2	Locknut M20*1.5	WARTTELMOER M20	50.220 PA.V035
PG	2	Cable gland M16*1.5	WARTTEL PA M16*1.5	50.616 PA.V035
PG	1	Reduction M20 -> M16*1.5	Reductie PA M20-M16*1.5	M20M16PA
PG	1	Locknut M16*1.5	WARTTELMOER M16	50.216 PA.V035
PG	2	Locknut M20*1.5 Nickel-plated EMC	PG 225 MPO1	50.225 MPO1
PG	2	Cable gland M16*1.5 Nickel-plated EMC	PG 225 MERV	50.625 MERV
CS	1	Encoder PULV0357/016 for 4 buttons	PG225	XG250
CS	1	Encoder PULV0357/016 for 4 buttons	CS250 0h	CS250
IOU1	1	Frequency converter 11kW	ATV71 H011 M4	ATV71 H011 M4
IOE1	1	Transformer circuit breaker 1..1.5A	GO2 E705	GO2E705
IOU1	1	Power Supply 400/24V 3A	ABL8P5S4030	ABL8P5S4030
IOU1	1	Emergency stop relay	XPS-A5121	XPS-A5121
11NS2	1	Safety switch + Pin	XCS-PA792 + XCS-211	XCS-PA792 + XCS-211
11NS1	1	Emergency stop	Z85 AS844	Z85 AS844
11NS1	1	element MC XAL	ZEN L1121	ZEN L1121
11S1	1	Pushbutton GREEN "START"	Z85 AA323	08.01.0237
12S1	1	element MO XAL	ZEN L1111	ZEN L1111
12S1	1	Switch handle	Z85 A02	Z85 A02
12S1	1	element MC XAL	ZEN L1121	ZEN L1121
12R1	1	element MO XAL	ZEN L1111	ZEN L1111
12R1	1	Trimpot 10K	Polimetrek 10K Z84	Polimetrek 10K Z84
12H1	1	Pot. meter	Z85 AD912	Z85 AD912
12H1	1	Fan	FAN 8314	FAN 8314
12H1	1	Fan filter		
12H1	1	Fan flapper guard		
X1	2	End bracket		
X1	1	2 Wire PE terminal 2.5mm²	WEID Z8W 35	250-1612 Niet kl.beh.
X1	12	2 Wire terminal 2.5mm²	WEID Z8E 2.5J	954000000
X1	1	End plate 200 2.5	WEID Z8U 2.5	1608940000
X1	1	End plate 200 2.5	WEID Z8U7W 1	1608510000
				160740000



E06866/UL230 / 3x 230V / 11kW / frequency drive

SYMBOL CODE

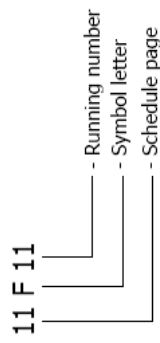

CORE CODE



DRAWING NUMBER

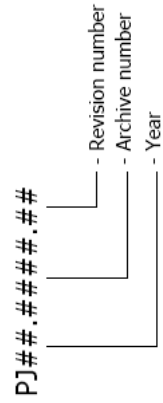

WIRE COLOR All wiring AWG

Main Voltage 230V

Phase

- L1
- L2
- L3
- Earth / PE

Colors

- Black
- Black
- Black
- Yellow/Green

Control Voltage

- Plus (24VDC) - White
- Hook-up wire - White
- Minus / Ground (24VDC) - White



	auxiliary contact	hulpcontact		signal lamp		Safety fuse	smeltevrijheid
	Power contact	vermogenscontact		hoorn		Fused switch, three-pole	schakelbare schieder
	NO contact, opens with time delay	maakcontact, vertraagd open		ampmeter		Fused disconnect, three-pole	schieder "kapsak"
	NO contact, closes with time delay	maakcontact, vertraagd sluitend		urenreder		Main switch	hoofdschakelaar
	NC contact, opens with time delay	verkeerscontact, vertraagd open		transformator		Circuit breaker, single-pole	installatieautomaat 1-poolig
	NC contact, closes with time delay	verkeerscontact, vertraagd sluitend		Contactor coil relay coil		Circuit breaker, two-pole	installatieautomaat 2-poolig
	Pushbutton rebound	druksnoep terugveerend		Contactor/relay coil, with pick-up delay		Circuit breaker, three-pole	installatieautomaat 3-poolig
	Pushbutton locking	druksnoep blijvend		Contactor/relay coil, with drop-out delay		Power circuit breaker, motor overload switch with switch mechanism	motorbeveiligingsschakelaar
	Rotary switch rebound	tip draaischakelaar		Contactor pulse coil relay pulse coil		Valve	elektrisch bediende klep
	Rotary switch locking	draaischakelaar		Tube light		Resistor with movable contact	regelbare weerstand
	Emergency stop rotary unlock	stopknop met draaibare vrijgave		Resistor / Heating		Terminal	rijgklem
	Thermostatic switch	thermostaat		Socket		Terminal with fuse	rijgklem met zekering
	Pressure switch	drukschakelaar		Current transformer		Rectifier	geïjzrichter
	Limit switch	endschakelaar					
	Proximity switch	naderingsschakelaar					

Mounting plate

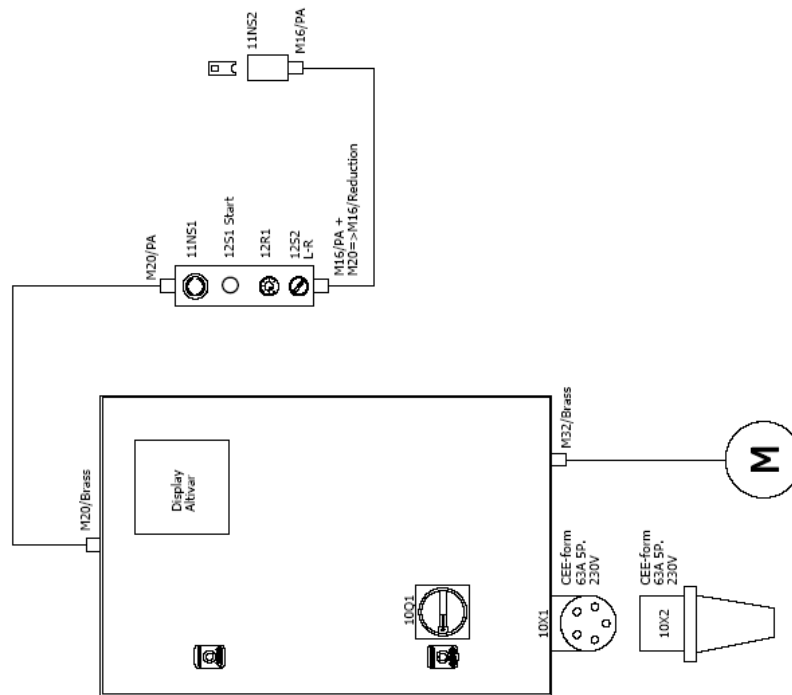
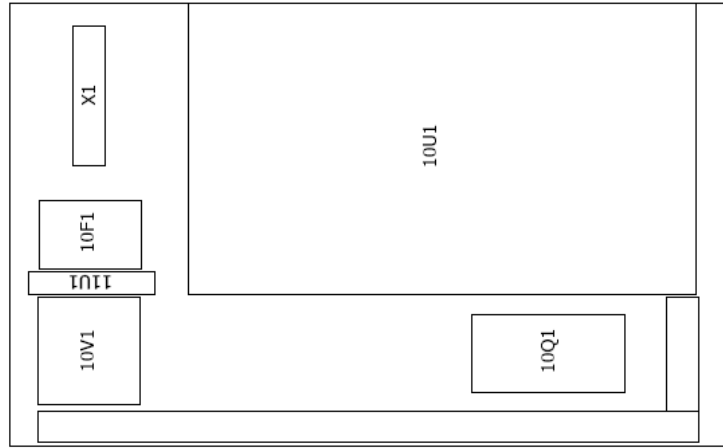

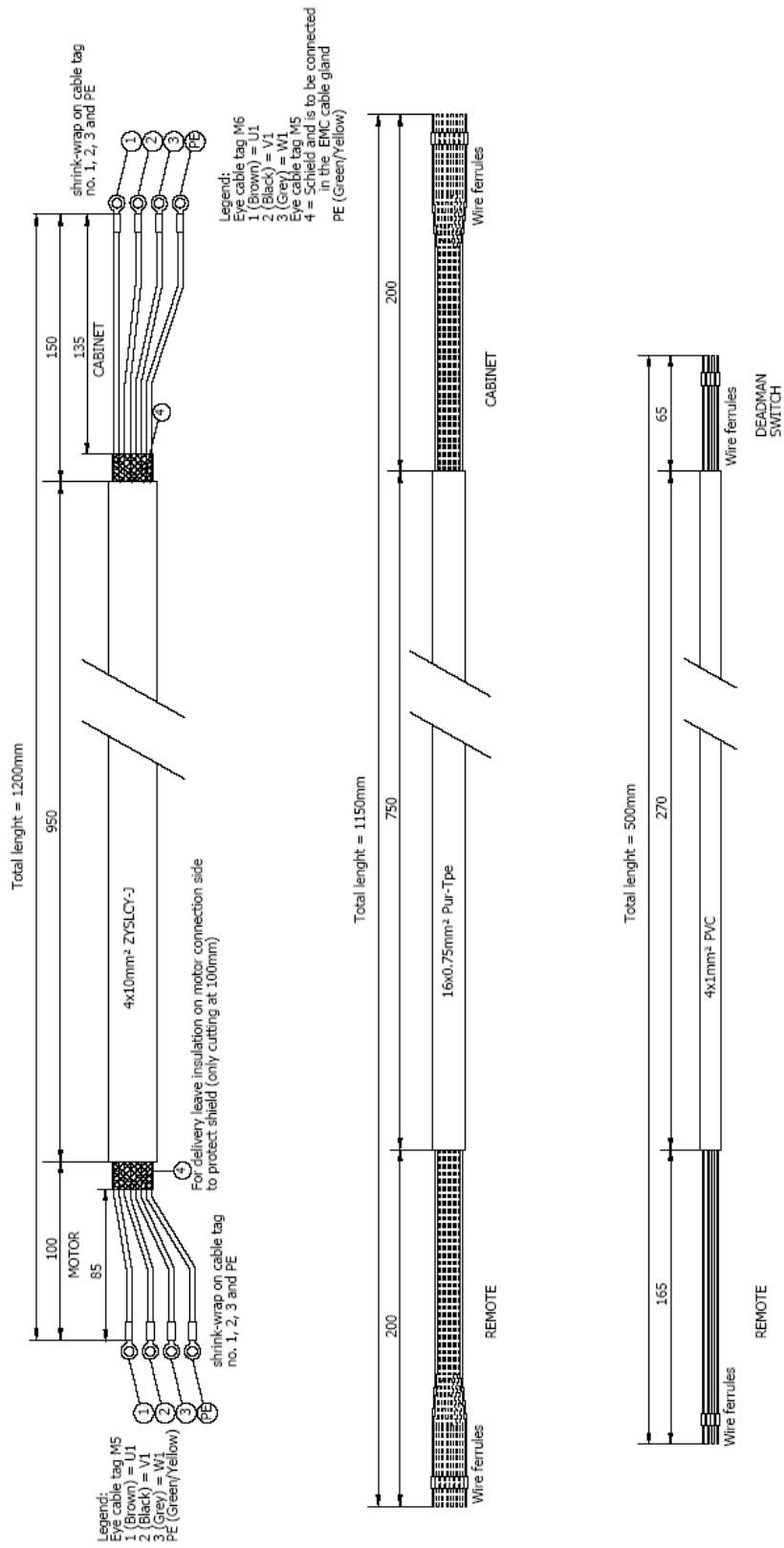

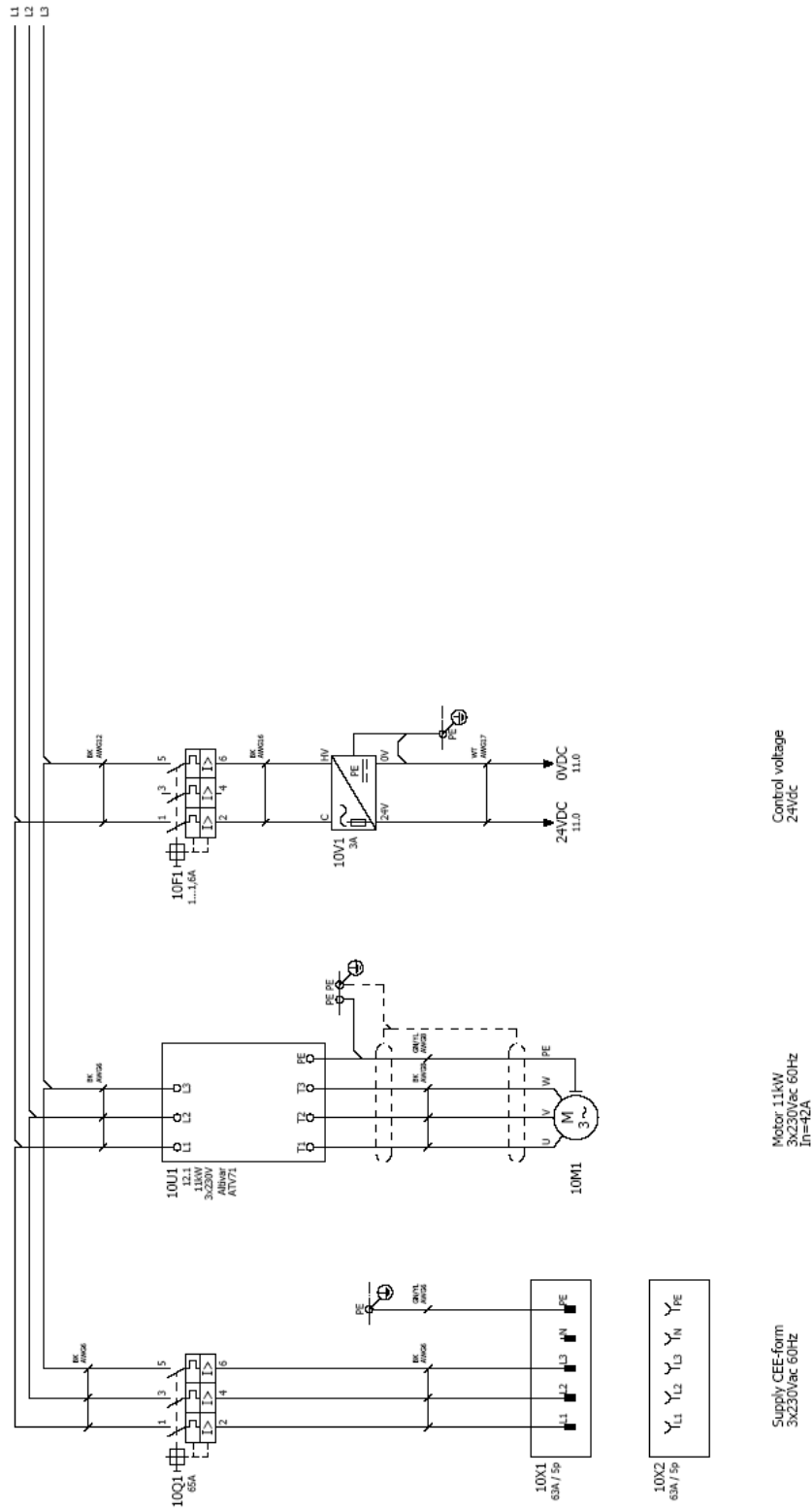

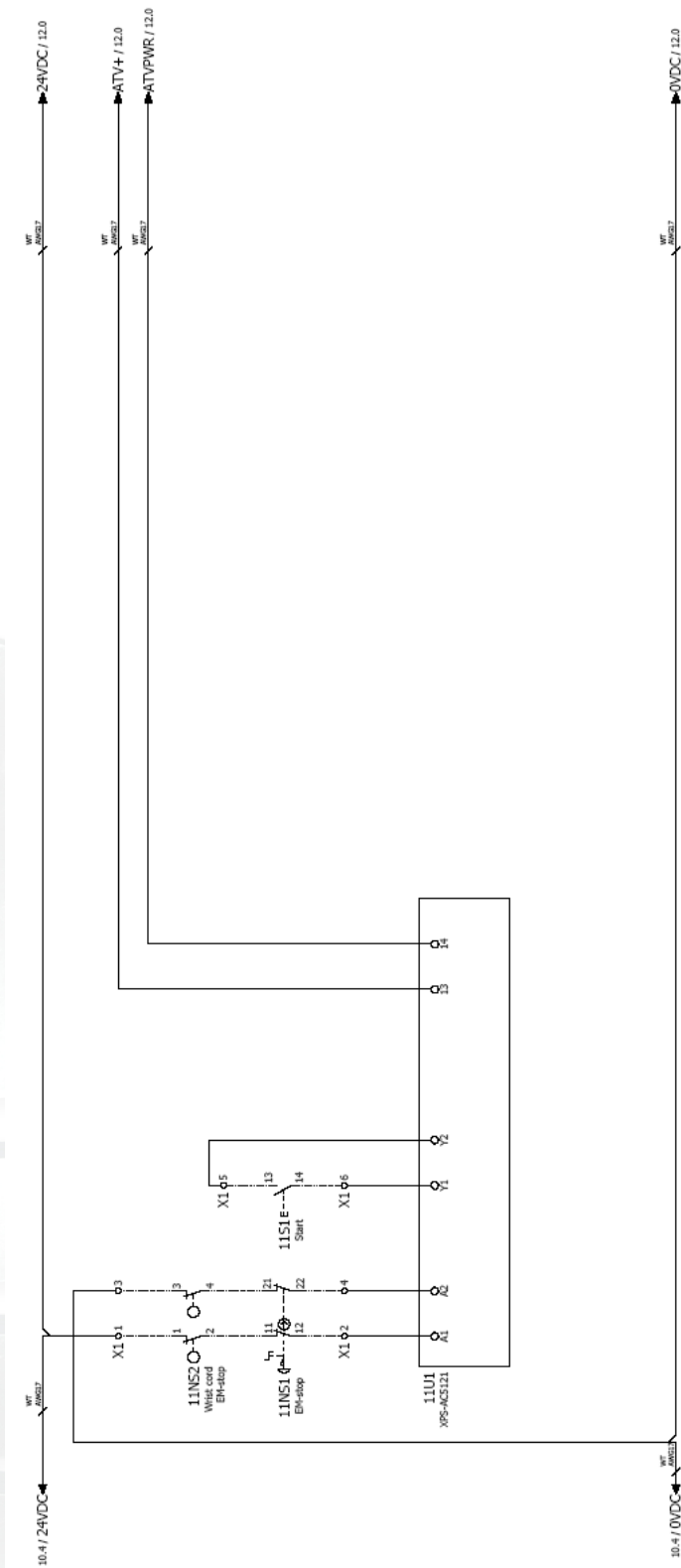

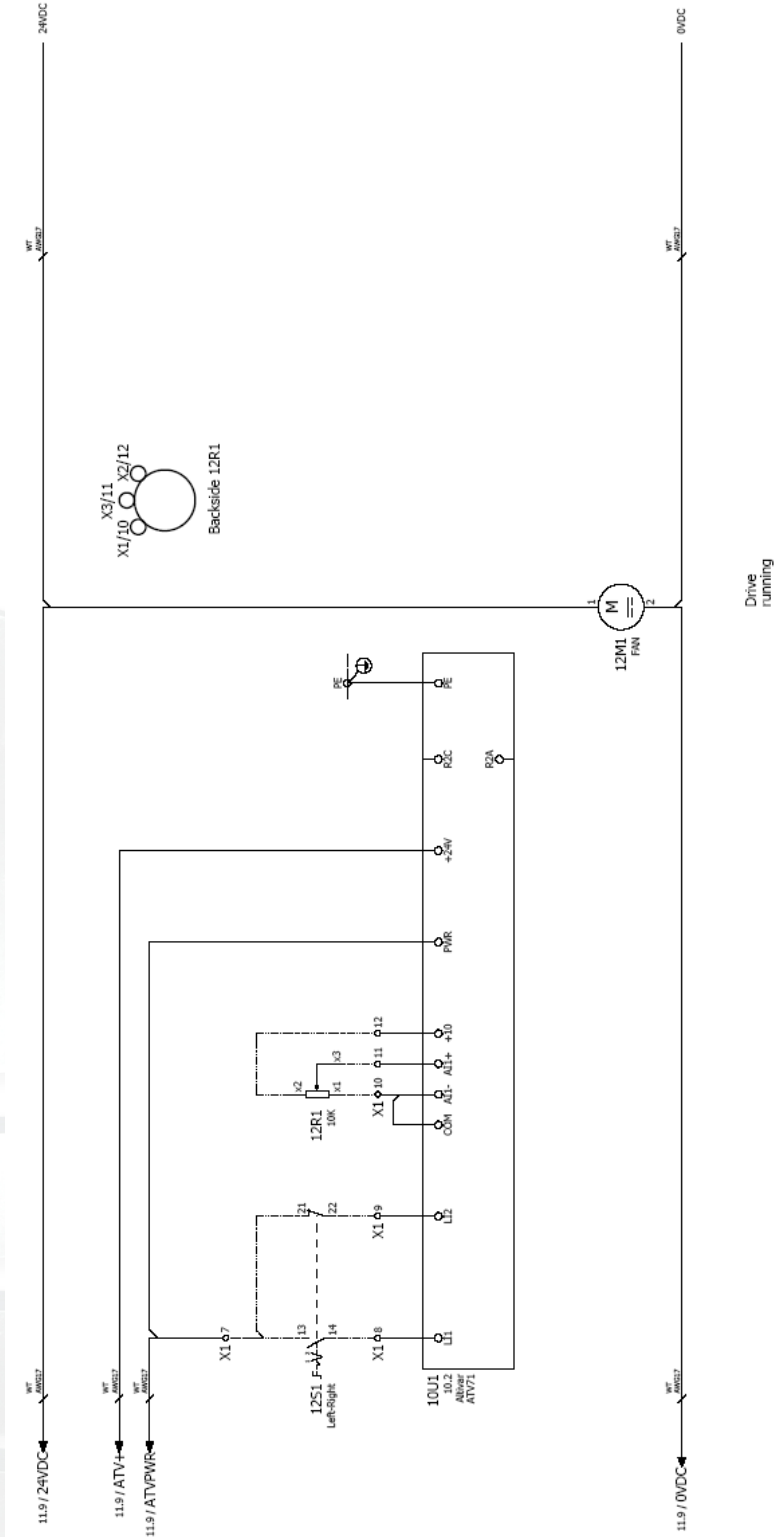



Parts list

device tag	Quantity	designation	Type number	part number
C06	1	Enclosure 600x400x200 with mounting plate 570x350	MMS 095-0300	MMS 060-M300
PG	1	Cable gland M12*1.5 Nickel-plated EMC	50.222 MIPOT	50.632 M18W
PG	1	Locknut M12*1.5 Nickel-plated EMC	50.222 MIPOT	50.222 MIPOT
PG	1	Cable gland M12*1.5 Nickel-plated EMC	WARTEL L460*1.5	50.630 M4L
PG	1	Locknut M12*1.5 Nickel-plated EMC	WARTEL M12*1.5	50.220 M1
PG	1	Cable gland M12*1.5 Nickel-plated EMC	WARTEL M12*1.5	50.220 M1
PG	2	Locknut M12*1.5	WARTEL M12*1.5	50.220 M1
PG	2	Cable gland M12*1.5	WARTEL M12*1.5	50.220 M1
PG	2	Cable gland M12*1.5	WARTEL M12*1.5	50.220 M1
PG	2	Locknut M12*1.5	WARTEL M12*1.5	50.220 M1
PG	1	Locknut M12*1.5	WARTEL M12*1.5	50.220 M1
PG	1	Reduction M20 -> M16*1.5	Reduction PA M20->M16*1.5	50.216 PA2035
PG	1	Locknut M20*1.5 Nickel-plated EMC	50.222 MIPOT	K00M18FA
PG	1	Cable gland M25*1.5 Nickel-plated EMC	50.625 M18W	50.225 MIPOT
PG	1	Enclosure RAL7035/7016 for 4 buttons	XAL D04	XAL D04
C08	1	63A CEE-form Wall outlet socket 9h IP57	ABL G35225	G35225
R0X1	1	63A CEE-form Socket 9h IP67	ABL K35225	K35225
R0Q1	1	Motor circuit breaker 65A 3p	TELE G03-P65	G03 P65
R0Q1	1	Large spacing UL	TELE G03-P65	G03 P65
R0Q1	1	Aux + back ON/OFF handle	G03M03	G03M03
R0U1	1	Frequency controller 11kW 3x230V	ATV71 HD11 M3X_3*230V	ATV71 HD11 M3X
R0F1	1	Transformer circuit breaker 1...1.6A	G02 RT06	G02RT06
R0V1	1	Power Supply 400/24V 3A	ABLBP55-4030	ABLBP55-4030
L1U1	1	Emergency stop relay	XPS-AC5121	XPS-AC5121
L1N62	1	Safety switch + Pin	XCS-PA792 + XCS-211	XCS-PA792 + XCS-211
L1N61	1	Emergency stop	ZB5 A6544	ZB5 A6544
L1S1	2	element NC 2XAL	ZBN L1121	ZBN L1121
L1S1	1	Pushbutton GREEN "START"	ZB5 A0533	0601.0237
L1S1	1	element NO 2XAL	ZBN L1111	ZBN L1111
L1S1	1	Switch handle	ZB5 A02	ZB5 A02
L1S1	1	element NC 2XAL	ZBN L1111	ZBN L1111
L1S1	1	element NO 2XAL	ZBN L1111	ZBN L1111
L1R1	1	Terminal block 10K 2B4	50.220 M1	50.220 M1
L1R1	1	Pin driver	ZB5 A0512	ZB5 A0512
L1R1	1	Fan	FAN 80*80*32 24VDC	FAN 80*80*32 24VDC
L1R1	1	Fan filter	Z31-336 6x4 1x3x1	Z31-336 6x4 1x3x1
L1R1	1	Fan finger guard	Z50-1612 1x4x1x3x1	Z50-1612 1x4x1x3x1

4. Fault diagnose frequency drive

For a complete overview of faults and how to resolve them, check the operating manual of the frequency drive or the CD, which are delivered with the machine.

If you put the CD in the computer, it will automatically go to the manuals.

Does the inverter shows an "INF" fault, reset the machine.

If the machine does not work after that, call you distributor.

To reset the machine, put out the power supply and wait 5 minutes.

Then start up the machine again. Call a technician if the machine still not works.

Fault	Name	Probable cause	Remedy
R I 2 F	[AI2 input]	<ul style="list-style-type: none"> Non-conforming signal on analog input AI2 	<ul style="list-style-type: none"> Check the wiring of analog input AI2 and the value of the signal
R n F	[Load slipping]	<ul style="list-style-type: none"> The encoder speed feedback does not match the reference 	<ul style="list-style-type: none"> Check the motor, gain and stability parameters Add a braking resistor Check the size of the motor/drive/load Check the encoder's mechanical coupling and its wiring
b D F	[DBR overload]	<ul style="list-style-type: none"> The braking resistor is under excessive stress 	<ul style="list-style-type: none"> Check the size of the resistor and wait for it to cool down Check the [DB Resistor Power] (brP) and [DB Resistor value] (brU) parameters, page 211
b r F	[Brake feedback]	<ul style="list-style-type: none"> The brake feedback contact does not match the brake logic control 	<ul style="list-style-type: none"> Check the feedback circuit and the brake logic control circuit Check the mechanical state of the brake
b U F	[DB unit sh. Circuit]	<ul style="list-style-type: none"> Short-circuit output from braking unit 	<ul style="list-style-type: none"> Check the wiring of the braking unit and the resistor Check the braking resistor
C r F 1	[Precharge]	<ul style="list-style-type: none"> Load relay control fault or charging resistor damaged 	<ul style="list-style-type: none"> Switch the drive off and then back on again Check the internal connections
C r F 2	[Thyr. soft charge]	<ul style="list-style-type: none"> DC bus charging fault (thyristors) 	<ul style="list-style-type: none"> Inspect/repair the drive
E C F	[Encoder coupling]	<ul style="list-style-type: none"> Break in encoder's mechanical coupling 	<ul style="list-style-type: none"> Check the encoder's mechanical coupling
E E F 1	[Control Eeprom]	<ul style="list-style-type: none"> Internal memory fault, control card 	<ul style="list-style-type: none"> Check the environment (electromagnetic compatibility) Turn off, reset, return to factory settings
E E F 2	[Power Eeprom]	<ul style="list-style-type: none"> Internal memory fault, power card 	<ul style="list-style-type: none"> Inspect/repair the drive
E n F	[Encoder]	<ul style="list-style-type: none"> Encoder feedback fault 	<ul style="list-style-type: none"> Check [Number of pulses] (PGI) and [Encoder type] (EnS), page 72 Check that the encoder's mechanical and electrical operation, its power supply and connections are all correct If necessary, reverse the direction of rotation of the motor ([Output Ph rotation] (PHr) parameter, page 88) or the encoder signals
F C F 1	[Out. contact. stuck]	<ul style="list-style-type: none"> The output contactor remains closed although the opening conditions have been met 	<ul style="list-style-type: none"> Check the contactor and its wiring Check the feedback circuit



Fault	Name	Probable cause	Remedy
H d F	[IGBT desaturation]	<ul style="list-style-type: none"> Short-circuit or grounding at the drive output 	<ul style="list-style-type: none"> Check the cables connecting the drive to the motor, and the insulation of the motor Perform the diagnostic tests via the [1.10 DIAGNOSTICS] menu
IL F	[Internal com. link]	<ul style="list-style-type: none"> Communication fault between option card and drive 	<ul style="list-style-type: none"> Check the environment (electromagnetic compatibility) Check the connections Check that no more than 2 option cards (max. permitted) have been installed on the drive Replace the option card Inspect/repair the drive
Inf 1	[Rating error]	<ul style="list-style-type: none"> The power card is different from the card stored 	<ul style="list-style-type: none"> Check the reference of the power card
Inf 2	[Incompatible PB]	<ul style="list-style-type: none"> The power card is incompatible with the control card 	<ul style="list-style-type: none"> Check the reference of the power card and its compatibility
Inf 3	[Internal serial link]	<ul style="list-style-type: none"> Communication fault between the internal cards 	<ul style="list-style-type: none"> Check the internal connections Inspect/repair the drive
Inf 4	[Internal MFG area]	<ul style="list-style-type: none"> Internal data inconsistent 	<ul style="list-style-type: none"> Recalibrate the drive (performed by Schneider Electric Product Support)
Inf 5	[Internal-option]	<ul style="list-style-type: none"> The option installed in the drive is not recognized 	<ul style="list-style-type: none"> Check the reference and compatibility of the option
Inf 7	[Internal-hard init.]	<ul style="list-style-type: none"> Initialization of the drive is incomplete 	<ul style="list-style-type: none"> Turn off and reset
Inf 8	[Internal-ctrl supply]	<ul style="list-style-type: none"> The control power supply is incorrect 	<ul style="list-style-type: none"> Check the control power supply
Inf 9	[Internal- I measure]	<ul style="list-style-type: none"> The current measurements are incorrect 	<ul style="list-style-type: none"> Replace the current sensors or the power card Inspect/repair the drive
Inf R	[Internal-mains circuit]	<ul style="list-style-type: none"> The input stage is not operating correctly 	<ul style="list-style-type: none"> Perform the diagnostic tests via the [1.10 DIAGNOSTICS] menu Inspect/repair the drive
Inf b	[Internal- th. sensor]	<ul style="list-style-type: none"> The drive temperature sensor is not operating correctly 	<ul style="list-style-type: none"> Replace the temperature sensor Inspect/repair the drive
Inf C	[Internal-time meas.]	<ul style="list-style-type: none"> Fault on the electronic time measurement component 	<ul style="list-style-type: none"> Inspect/repair the drive
Inf E	[Internal- CPU]	<ul style="list-style-type: none"> Internal microprocessor fault 	<ul style="list-style-type: none"> Turn off and reset. Inspect/repair the drive
OC F	[Overcurrent]	<ul style="list-style-type: none"> Parameters in the [SETTINGS] (SEt-) and [1.4 MOTOR CONTROL] (drC-) menus are not correct Inertia or load too high Mechanical locking 	<ul style="list-style-type: none"> Check the parameters Check the size of the motor/drive/load Check the state of the mechanism
P r F	[Power removal]	<ul style="list-style-type: none"> Fault with the drive's "Power removal" safety function 	<ul style="list-style-type: none"> Inspect/repair the drive
SC F 1	[Motor short circuit]	<ul style="list-style-type: none"> Short-circuit or grounding at the drive output Significant earth leakage current at the drive output if several motors are connected in parallel 	<ul style="list-style-type: none"> Check the cables connecting the drive to the motor, and the insulation of the motor Perform the diagnostic tests via the [1.10 DIAGNOSTICS] menu Reduce the switching frequency Connect chokes in series with the motor
SC F 2	[Impedant sh. circuit]		
SC F 3	[Ground short circuit]		
SO F	[Overspeed]	<ul style="list-style-type: none"> Instability or driving load too high 	<ul style="list-style-type: none"> Check the motor, gain and stability parameters Add a braking resistor Check the size of the motor/drive/load
SP F	[Speed fedback loss]	<ul style="list-style-type: none"> Encoder feedback signal missing 	<ul style="list-style-type: none"> Check the wiring between the encoder and the drive Check the encoder
t n F	[Auto-tuning]	<ul style="list-style-type: none"> Special motor or motor whose power is not suitable for the drive Motor not connected to the drive 	<ul style="list-style-type: none"> Check that the motor/drive are compatible Check that the motor is present during auto-tuning If an output contactor is being used, close it during auto-tuning

Fault	Name	Probable cause	Remedy
A P F	[Application fault]	<ul style="list-style-type: none"> Controller Inside card fault 	<ul style="list-style-type: none"> Please refer to the card documentation
b L F	[Brake control]	<ul style="list-style-type: none"> Brake release current not reached Brake engage frequency threshold [Brake engage freq] (bEn) only regulated when brake logic control is assigned 	<ul style="list-style-type: none"> Check the drive/motor connection Check the motor windings Check the [Brake release I FW] (lbr) and [Brake release I Rev] (lrd) settings, page 148. Apply the recommended settings for [Brake engage freq] (bEn)
C n F	[Com. network]	<ul style="list-style-type: none"> Communication fault on communication card 	<ul style="list-style-type: none"> Check the environment (electromagnetic compatibility) Check the wiring Check the time-out Replace the option card Inspect/repair the drive
C D F	[CAN com.]	<ul style="list-style-type: none"> Interruption in communication on the CANopen bus 	<ul style="list-style-type: none"> Check the communication bus Check the time-out Refer to the CANopen user's manual
E P F 1	[External flt-LI/Bit]	<ul style="list-style-type: none"> Fault triggered by an external device, depending on user 	<ul style="list-style-type: none"> Check the device, which caused the fault, and reset
E P F 2	[External fault com.]	<ul style="list-style-type: none"> Fault triggered by a communication network 	<ul style="list-style-type: none"> Check for the cause of the fault and reset
F C F 2	[Out. contact. open.]	<ul style="list-style-type: none"> The output contactor remains open although the closing conditions have been met 	<ul style="list-style-type: none"> Check the contactor and its wiring Check the feedback circuit
L C F	[input contactor]	<ul style="list-style-type: none"> The drive is not turned on even though [Mains V. time out] (LCt) has elapsed 	<ul style="list-style-type: none"> Check the contactor and its wiring Check the time-out Check the line/contactor/drive connection
L F F 2 L F F 3 L F F 4	[AI2 4-20mA loss] [AI3 4-20mA loss] [AI4 4-20mA loss]	<ul style="list-style-type: none"> Loss of the 4-20 mA reference on analog input AI2, AI3 or AI4 	<ul style="list-style-type: none"> Check the connection on the analog inputs
D b F	[Overbraking]	<ul style="list-style-type: none"> Braking too sudden or driving load 	<ul style="list-style-type: none"> Increase the deceleration time Install a braking resistor if necessary Activate the [Dec ramp adapt.] (brA) function, page 127, if it is compatible with the application
D H F	[Drive overheat]	<ul style="list-style-type: none"> Drive temperature too high 	<ul style="list-style-type: none"> Check the motor load, the drive ventilation and the ambient temperature. Wait for the drive to cool down before restarting
D L F	[Motor overload]	<ul style="list-style-type: none"> Triggered by excessive motor current 	<ul style="list-style-type: none"> Check the setting of the motor thermal protection, check the motor load. Wait for the drive to cool down before restarting
D P F 1	[1 output phase loss]	<ul style="list-style-type: none"> Loss of one phase at drive output 	<ul style="list-style-type: none"> Check the connections from the drive to the motor



Fault	Name	Probable cause	Remedy
D P F 2	[3 output phase loss]	<ul style="list-style-type: none"> Motor not connected or motor power too low Output contactor open Instantaneous instability in the motor current 	<ul style="list-style-type: none"> Check the connections from the drive to the motor If an output contactor is being used, parameterize [Output Phase Loss] (OPL) = [Output out] (OAC), page 201 Test on a low power motor or without a motor: In factory settings mode, motor phase loss detection is active [Output Phase Loss] (OPL) = [Yes] (YES). To check the drive in a test or maintenance environment, without having to use a motor with the same rating as the drive (in particular for high power drives), deactivate motor phase loss detection [Output Phase Loss] (OPL) = [No] (nO) Check and optimize the following parameters: [IR compensation] (UFR), page 20, [Rated motor volt.] (UnS) and [Rated mot. current] (nCr), page 85, and perform [Auto tuning] (tUn), page 88
D S F	[Mains overvoltage]	<ul style="list-style-type: none"> Mains voltage too high Disturbed mains supply 	<ul style="list-style-type: none"> Check the mains voltage
D t F 1	[PTC1 overheat]	<ul style="list-style-type: none"> Overheating of the PTC1 probes detected 	<ul style="list-style-type: none"> Check the motor load and motor size Check the motor ventilation Wait for the motor to cool before restarting Check the type and state of the PTC probes
D t F 2	[PTC2 overheat]	<ul style="list-style-type: none"> Overheating of the PTC2 probes detected 	
D t F L	[LI6=PTC overheat]	<ul style="list-style-type: none"> Overheating of PTC probes detected on input LI6 	
P t F 1	[PTC1 probe]	<ul style="list-style-type: none"> PTC1 probes open or short-circuited 	
P t F 2	[PTC2 probe]	<ul style="list-style-type: none"> PTC2 probes open or short-circuited 	<ul style="list-style-type: none"> Check the PTC probes and the wiring between them and the motor/drive
P t F L	[LI6=PTC probe]	<ul style="list-style-type: none"> PTC probes on input LI6 open or short-circuited 	
S C F 4	[IGBT short circuit]	<ul style="list-style-type: none"> Power component fault 	
S C F 5	[Motor short circuit]	<ul style="list-style-type: none"> Short-circuit at drive output 	
S L F 1	[Modbus com.]	<ul style="list-style-type: none"> Interruption in communication on the Modbus bus 	<ul style="list-style-type: none"> Check the communication bus Check the time-out Refer to the Modbus user's manual
S L F 2	[PowerSuite com.]	<ul style="list-style-type: none"> Fault communicating with PowerSuite 	<ul style="list-style-type: none"> Check the PowerSuite connecting cable Check the time-out
S L F 3	[HMI com.]	<ul style="list-style-type: none"> Fault communicating with the graphic display terminal 	<ul style="list-style-type: none"> Check the terminal connection Check the time-out
S r F	[Torque time-out]	<ul style="list-style-type: none"> The time-out of the torque control function is attained 	<ul style="list-style-type: none"> Check the function's settings Check the state of the mechanism
S S F	[Torque/current lim]	<ul style="list-style-type: none"> Switch to torque limitation 	<ul style="list-style-type: none"> Check if there are any mechanical problems Check the parameters of [TORQUE LIMITATION] (tLA-) page 171 and the parameters of fault [TORQUE OR I LIM. DETECT.] (tld-), page 210
t J F	[IGBT overheat]	<ul style="list-style-type: none"> Drive overheated 	<ul style="list-style-type: none"> Check the size of the load/motor/drive Reduce the switching frequency Wait for the motor to cool before restarting

Fault	Name	Probable cause	Remedy
C F F	[Incorrect config.]	<ul style="list-style-type: none"> Option card changed or removed Control card replaced by a control card configured on a drive with a different rating The current configuration is inconsistent 	<ul style="list-style-type: none"> Check that there are no card errors In the event of the option card being changed/removed deliberately, see the remarks below Check that there are no card errors In the event of the control card being changed deliberately, see the remarks below Return to factory settings or retrieve the backup configuration, if it is valid (see page 223)
C F I	[Invalid config.]	<ul style="list-style-type: none"> Invalid configuration The configuration loaded in the drive via the bus or communication network is inconsistent 	<ul style="list-style-type: none"> Check the configuration loaded previously Load a compatible configuration
H C F	[Cards pairing]	<ul style="list-style-type: none"> The [CARDS PAIRING] (PPI-) function, page 212, has been configured and a drive card has been changed 	<ul style="list-style-type: none"> In the event of a card error, reinsert the original card Confirm the configuration by entering the [Pairing password] (PPI) if the card was changed deliberately
P H F	[Input phase loss]	<ul style="list-style-type: none"> Drive incorrectly supplied or a fuse blown Failure of one phase 3-phase ATV71 used on a single-phase line supply Unbalanced load <p>This protection only operates with the drive on load</p>	<ul style="list-style-type: none"> Check the power connection and the fuses Use a 3-phase mains supply Disable the fault by [Input phase loss] (IPL) = [No] (nO) (page 202)
U S F	[Undervoltage]	<ul style="list-style-type: none"> Line supply too low Transient voltage dip Damaged pre-charge resistor 	<ul style="list-style-type: none"> Check the voltage and the parameters of [UNDERVOLTAGE MGT] (USb-), page 205 Replace the pre-charge resistor Inspect/repair the drive



**Headquarter
Blastrac The Netherlands**

Utrechthaven 12
NL – 3433 PN Nieuwegein
Tel – 0031 30 601 88 66
Fax – 0031 30 601 83 33
Info@blastrac.nl

Blastrac Poland

Golina, Dworcowa 47a
PL – 63-200 Jarocin
Tel – 0048 627 40 41 50
Fax – 0048 627 40 41 51
Info@blastrac.pl

Blastrac Italy

S.S. 10 Padana Inferiore, 41
IT – 29012 Caorso (PC)
Tel – 0039 0523 81 42 41
Fax – 0039 0523 81 42 45
Info@blastrac.it

Blastrac United Kingdom

Unit 2, Outgang Lane, Dinnington
Sheffield, South Yorkshire
GB – S25 3QY, England
Tel – 0044 1909 56 91 18
Fax – 0044 1909 56 75 70
Info@blastrac.co.uk

Blastrac Germany

Richard Byrd Straße 15
D – 50829 Köln (Ossendorf)
Tel – 0049 221 70 90 32 0
Fax – 0049 221 70 90 32 22
Info@blastrac.de

Blastrac Spain

Calle Copernico, 16
Nave 2
E – 28820 Coslada
Tel – 0034 91 660 10 65
Fax – 0034 91 672 72 11
Info@blastrac.com.es

Blastrac France (ZI)

29, Avenue des Temps Modernes
F – 86360 Chasseneuil du Poitou
Tel – 0033 549 00 49 20
Fax – 0033 549 00 49 21
Info@blastrac.fr

Blastrac Ukraine

Nezalezhnosti 14, of. 21
UA – 07400 Brovary
Tel – 0038 44 222 51 28
Fax – 0038 44 277 98 29
Info@blastrac.com.ua