



ORIGINAL in English
OPERATING INSTRUCTIONS
BMP-4000E BMP-400RC
VERSION 1.9





Inspection comments

Inspection before initial operation on:	_____
By:	_____
Date of initial operation:	_____
Serial number & Year of manufacture:	_____

Recurring inspections / maintenance log

Date / Hour counter	Findings	Repairs / Cleaning	Test on	By*

*Competent person

Table of contents

Inspection comments	2
Table of contents	3
1. Introduction	4
2. Machine description	4
Applications.....	4
3. Safety	7
3.1 Work area safety	7
3.2 Electrical safety	7
3.3 Personal safety.....	8
3.4 Machine safety general.....	8
3.5 Maintenance safety	8
3.7 Dust collector safety	9
3.8 Hydraulic safety	9
3.9 Transport safety.....	10
3.10 Signs on the machine.....	12
4. Initial operation	13
4.1 Checkpoints of electrical safety	13
4.2 Checkpoints of machine safety	13
Work area	13
4.3 Removing the drum	14
4.4 Changing picks on the drum.....	15
4.5 Mounting the drum	15
5. Operating BMP-4000	16
Main screen.....	16
Settings screen.....	17
Alarm screen	18
IO pages.....	19
Controls.....	20
5.1 Switching on the machine.....	21
5.2 Leveling the machine (without milling)	21
5.3 Driving the machine (without milling).....	22
5.4 Working with the machine	22
5.5 Folding in the wheels	23
5.6 Tips for milling and working with the machine	23
5.7 Remote Control	24
6. Maintenance.....	26
6.1 Changing of hydraulic motor and checking coupling buffer	27
6.2 Maintenance of bearings	27
6.3 Replacing the shock absorbers	28
7. Troubleshooting	30
8. Technical data.....	31
Vibration level:	32
Noise level: (under load).....	32



1. Introduction

Before use, operators shall be provided with information, instruction and training for the use of the machine and the substances for which it is to be used, including the safe method of removal and disposal of the material collected. All persons who are working with or maintaining this machine must read the manual carefully and understand it fully. In case you sell the unit, hand the operating instructions on to the next owner. Keep this manual always with the machine, to enable it to be referred to at any time. Any other work not covered by this operating manual must not be carried out. Always use common sense when working with machines.

This machine is designed for industrial use by professionals. **Only authorized and trained personnel may operate this machine.** This machine is not intended for use by persons (including children) with reduced physical, sensory or mental capabilities, or lack of experience and knowledge. **Blastrac BV** offers a course on the use of the machine in order to make the operating and maintenance personnel familiar with all elements of the machine.

2. Machine description

The Blastrac self ride scarifier BMP-4000 is an electric machine for indoor use only. The BMP-4000 can be used for milling concrete, asphalt, for removing of coatings or for sawing concrete.

Because of the heavy weight of the machine, you can remove a lot of material at once and in combination with a suitable Blastrac dust collector, which is obliged, the machine works almost dust free.

Due to the fine adjustment of both legs and the integrated height levelling system, you can adjust the work depth of the machine up to the millimetre accurate.

Because of the accurate adjustment it is possible to give the surface a light or heavy treatment.

The milling picks are positioned in a way to create a very nice and fine milling pattern.

Applications

The scarifier is a very versatile machine and with the appropriate picks on the drum or with the sawing drum it may be used for the following applications:

- Remove layers of concrete or asphalt
- To roughen concrete or asphalt
- To clean most horizontal surfaces
- To remove coatings
- To remove road markings
- To make non-slip surfaces
- To make lines in concrete
- To shave off thin layers of concrete

The force of impact of a cutter is controlled by the depth adjustment. With the right depth adjustment, the best performance is obtained to give a desired result.

The use of a suitable Blastrac dust collector ensures dust-free operation of the machine, clean air at the workspace and raises the life span of the machine.

Due to the dust collector the picks will keep turning in the drum and this will help the picks to wear off even.

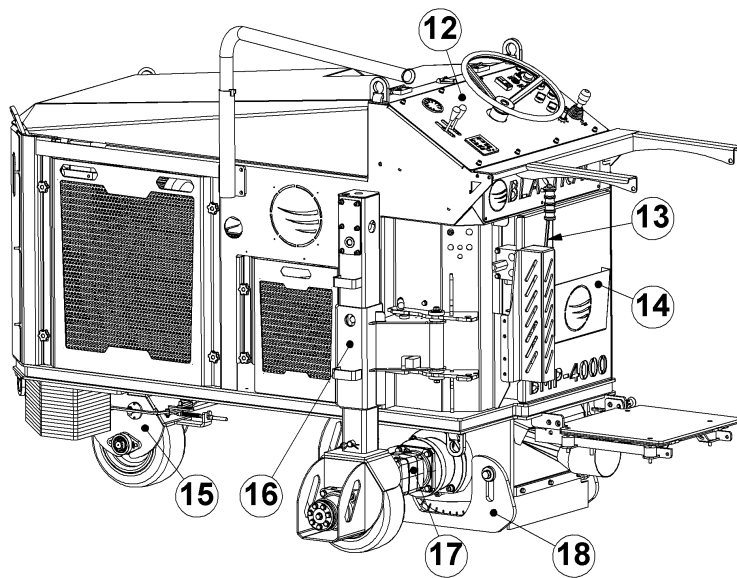
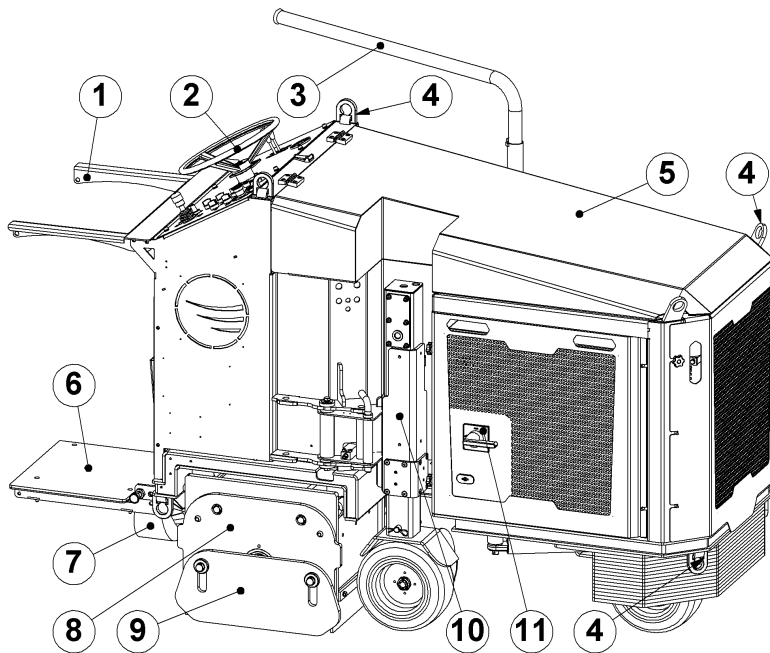

1	Operator support bracket	10	Right Hand back wheel (measuring system optional)
2	Steering wheel	11	Electro box with main switch (E-version)
3	Electric cable guide (E-version)	12	Control panel
4	Lifting points	13	Hand brake
5	Bonnet	14	Manual storage compartment
6	Operator platform with safety switch	15	Front steering wheel
7	Dust hose connection 150mm	16	Left Hand back wheel with measuring system
8	Side plate drum housing	17	Hydraulic milling motor
9	Right Hand slide plate	18	Left Hand slide plate

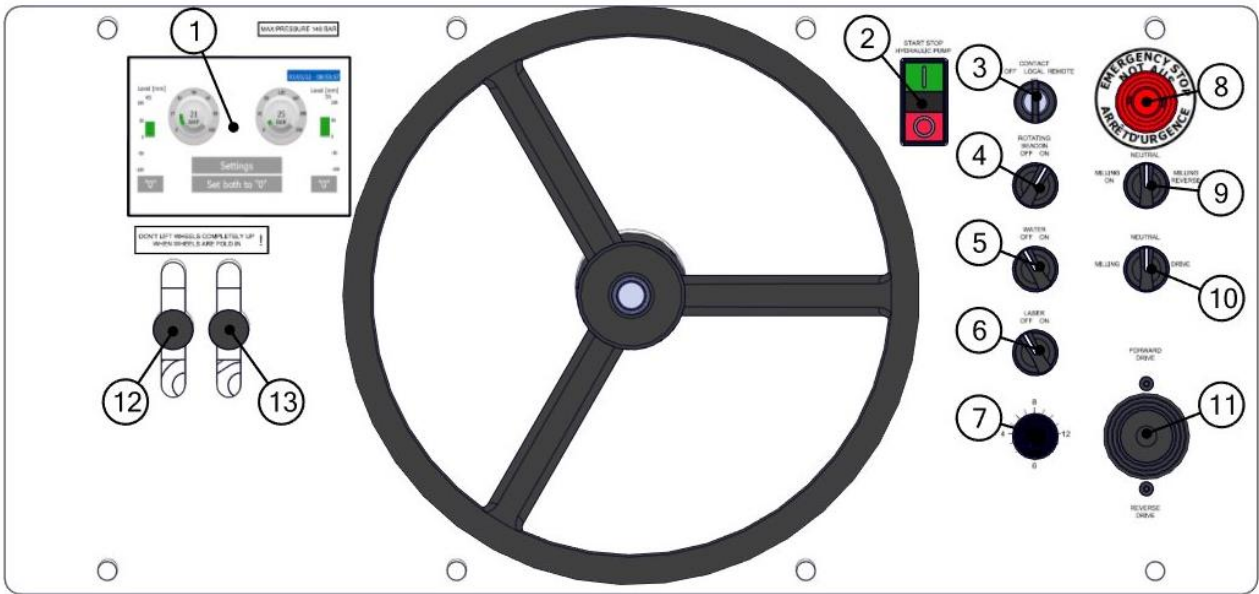

Control elements			
1	Control panel	8	Emergency stop button
2	Hydraulic motor ON/OFF	9	Switch for milling motor: MILLING ON/NEUTRAL/MILLING REVERSE
3	Contact with key OFF / LOCAL / REMOTE	10	Switch for operating mode: MILLING/NEUTRAL/DRIVE
4	Switch for rotating beacon ON/OFF (optional)	11	Joystick for driving forward/backwards
5	Worklight ON/OFF (optional)	12	Left Hand back wheel UP/DOWN
6	Water pump ON/OFF (optional)	13	Right Hand back wheel UP/DOWN
7	Driving speed selection button (1-10)		

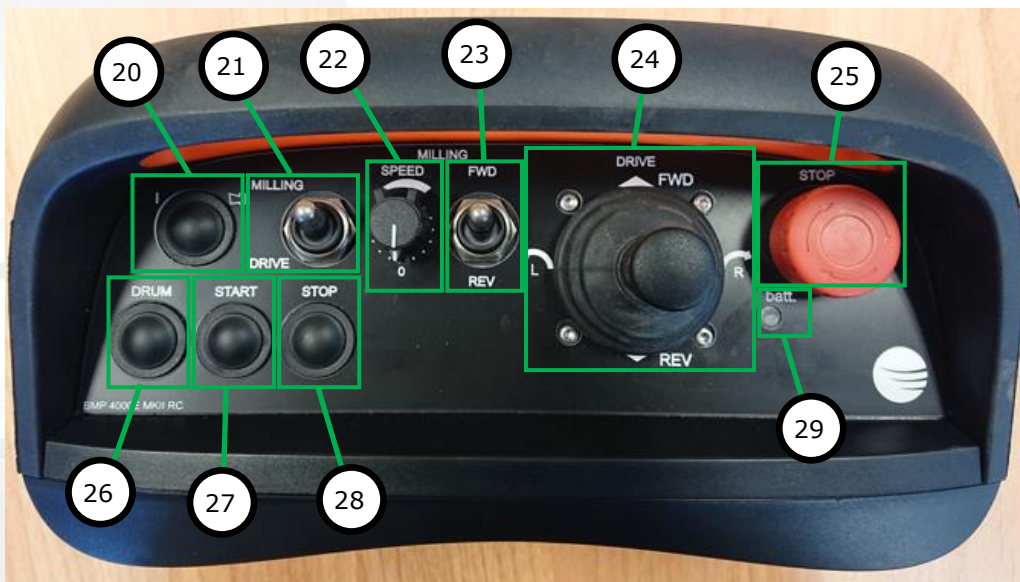

Remote Control elements			
20	Connect remote control	25	Emergency stop button
21	Switch for operating mode: MILLING/NEUTRAL/DRIVE	26	Drum ON/OFF
22	Driving speed selection button (1-10)	27	Start hydraulic system
23	Switch for working direction MILLING forward/NEUTRAL/MILLING reverse	28	Stop Hydraulic system
24	Joystick for driving	29	Battery indicator



3. Safety



Warning!

Read all safety warnings and all instructions.

Failure to follow the warnings and instructions may result in electric shock, fire, explosions and / or serious injuries.

Only authorized and trained personnel may operate this machine !

This machine is not intended for use by persons (including children) with reduced physical, sensory or mental capabilities, or lack of experience and knowledge.

It is the responsibility of the user to analyse the surface to be treated. The surface may not contain any substances which could pose a fire-, explosion- or health risk when treated. The user should make a risk assessment on the basis of the information obtained about the surface to be treated and take proper precautions for the work to be performed.

In case of any inappropriate usage, improper operation or repair, the producer shall be exempt from liability.

Maintenance work that goes beyond the scope described in this manual must only be performed by qualified technicians.

3.1 Work area safety

- a) Do not use the machine in heavy rain or very wet locations.
- b) **Avoid dangerous environments: never work in the presence of explosive atmospheres, in the presence of flammable liquids, gases or dust. Remove materials or debris that may be ignited by sparks.**
In some cases sparks could be created by milling / sawing.
- c) Keep work area clean and make sure there is enough ambient light on the work area. Cluttered or dark areas invite accidents.
- d) Keep children and bystanders away while operating the machine. They are likely not to foresee the potential dangers of the machine. Distractions could cause you to lose control of the machine.
- e) Persons who are not operating the machine must not be permitted to stay in the surrounding area of at least 15 meter from the machine.
- f) Never use the machine when the surface is not clear and if there is a risk of stumbling or tripping.
- g) Remove electrical cables and dust hoses from the surface to be treated and driving direction of the machine.
- h) Make sure that there is nothing standing or situated on the surface to be treated.
- i) Make sure the machine can travel over all inequalities on the surface.
- j) Check if there are any obstacles that can snag the cables or dusthoses when the machine is moving.
- k) Remove reinforcing steel or other objects protruding from the surface in order to prevent damage to the machine.
- l) **Warning! Make sure that the surface to be treated does not contain dangerous materials such as: - combustible or explosive dusts or substances.
- carcinogenic or pathogenic dusts or substances.**
In these cases, additional safety measures should be used. Always mind the local safety requirements. Contact your dealer for additional options.
- m) Effective organizational measures must be taken to prevent that employees are present in the work area of this machine. If this is not possible, effective traffic rules must be adopted.
- n) If the proper execution of the work requires the presence of workers in the work zone, it is mandatory to take effective measures to prevent them from being injured by the machine.
- o) It is forbidden to use/drive the machine on public roads, pavements, etc. unless they are closed off from the general public and other traffic.
- p) Only work on locations which are adequately ventilated.

3.2 Electrical safety

- a) Use only extension cables for extending the main cable that are sized and marked in accordance with the overall power consumption of the machine. Do not use damaged extension cables.
- b) Electrical cables must be rolled entirely off of the reels before use.
- c) Any damages to the electric cables and/or electrical components is not permitted.
- d) The voltage on the identification plate must comply with the power supply.
- e) Use an electrical power supply connection with earth connection and earth leakage circuit breaker.



- f) The circuit breaker of the power supply must have a "D" characteristic. Circuit breakers with a "C" or "B" characteristic can give problems when switching the motor on.
- g) **Keep the machine original; The machine is always equipped with an earthed connection, do not change this** and always use earthed cables with an earthed plug.
- h) Inspect and test the electrical components regularly. The electrical components have to satisfy with the requirements set out in the harmonised norm EN60204-1.
- i) Always call a skilled electrician or your distributor when you have questions about the safety of the electrical components.
- j) Work on electrical equipment or operating materials may only be undertaken by a skilled electrician or by trained persons under the guidance and supervision of a skilled electrician as well as in accordance with the electrical engineering regulations.
- k) Do not abuse the cord. Never use the cord for unplugging the machine. Keep the cord away from heat, oil, sharp edges or moving parts. Damaged or entangled cords increase the risk of electric shock.
- l) Be careful with water on the treated surface. Electrical cables must not come into contact with water.
- m) The main power switch on the machine must be in the "Off" position before connecting to the power supply.
- n) During a long standstill of the machine, pull out the main plug.

3.3 Personal safety

a) Always wear Personal Protective Equipment while working with or around the machine!

- Dust mask class FFP3 or higher
- Hearing protection
- Safety glasses with lateral protection
- Protecting gloves
- Safety shoes
- b) Always wear close-fitting protective clothing. Do not wear loose clothing or jewellery. Keep your hair, clothing and gloves away from moving parts.
- c) Stay alert, watch what you are doing and use common sense when operating the machine.
- d) The cord of the deadman switch key should always be fastened on your arm or on to your clothing.
- e) Pull out the key of the deadman switch before any inspections, adjustments and/or maintenance work is started.
- f) Always use the operator support bracket for your own safety.
- g) Always seek professional medical attention immediately in case of injury.

3.4 Machine safety general

- a) Safety functions and operating functions must work correct.
- b) No loose bolts and nuts permitted.
- c) Never operate machine without the guards and/or safety devices in place.
- d) Never change anything on the safety devices on the machine!
- e) The machine, specially the handle grips and operator platform must be free of fats/oils and have to be dry.
- f) All repair work has to be done by qualified Blastrac personnel, this guarantees a safe and reliable machine.
- g) Always use original Blastrac spare parts, cutters, sawing blades and picks. Otherwise Blastrac BV cannot guarantee the safety of the machine. Only original Blastrac parts meet the factory specifications and quality. This will ensure the best performance. The part numbers can be found in the Service Manual.
- h) Make sure the drum with picks/cutters is in good condition and the picks/cutters can turn free in the drum.
- i) Caution! The machine can heat up during milling/cutting, don't risk getting burned, always wear protective clothing and gloves.
- j) The machine contains rotating parts, which are protected with a sliding cover.
- k) Warning! Milling can create sparks under certain conditions!

3.5 Maintenance safety

- a) Pull out the main plug before starting inspections and repair on the machine. The main switch can be locked in the "OFF" position by using a padlock and placing it through the main switch.
- b) Wait for a complete standstill of all drives before any inspections, adjustments and / or maintenance work is started.
- c) Block machine in stable position before doing any maintenance work.
- d) Failures due to inadequate or incorrect maintenance may generate very **high repair costs** and long standstill periods of the machine. **Regular** maintenance therefore is imperative.
- e) Operational safety and service life of the machine depends, among other things, on proper maintenance.
- f) Prevent premature wear by keeping the machine as dust free as possible. Clean the machine for this reason regularly with a dust collector and non-aggressive materials.



Never use a high pressure water cleaner to clean the machine.

- g) It is advisable to stock all spare parts or wear parts that cannot be supplied quickly. As a rule, production standstill periods are more expensive than the cost for the corresponding spare part.
- h) To allow the user to carry out maintenance operations, the machine must be disassembled, cleaned and inspected as far as reasonably possible, without causing hazards for the maintenance staff or other people.
- i) The suitable precautions include decontamination before disassembling the machine, adequate filtered ventilation of the exhaust air from the room in which it is disassembled, cleaning of the maintenance area and suitable personal protection equipment.
- j) The external parts of the machine must be decontaminated by cleaning and vacuuming methods, de-dusted before being taken out from the hazardous zone. All parts of the machine must be considered as contaminated when they are removed from the hazardous zone and appropriate actions must be taken to prevent dust from dispersing.
- k) When maintenance or repair procedures are carried out, all the contaminated elements that cannot be properly cleaned, must be destroyed.
- l) These elements must be disposed of in sealed bags according to the applicable regulations and in accordance with the local laws governing the disposal of such material.
- m) This procedure must also be followed when the filters have to be disposed.
- n) A second person must be deployed who can disengage the hydraulics and switch off the PTO (Hydraulic unit) in an emergency if work on live parts is necessary. The work area must be sealed off using a red and white safety chain and a danger sign. For the electrical parts, use a tool that is insulated against voltages.
- o) WARNING! Do not weld, flame cut or perform grinding works on or near the machine. Danger of fire or explosion exists!**
- p) Provide adequate ventilation when working in a confined space.
- q) Secure the maintenance area if necessary.

3.7 Dust collector safety

- a) **Always use a suitable Blastrac dust cleaner** to ensure a dust-free operation of the machine and clean air at the workspace. Also the airflow helps to cool the machine and prevents overheating.
- b) Carefully read the Operating Instructions of the dust collector before use.
- c) **The dust container/bag of the dust collector must be emptied regularly.** Comply with the local waste treatment regulations considering the removed material.
- d) The dust hose must be connected properly with a hose clamp and industrial tape.
- e) The dust hose must be undamaged and free of obstructions.
- f) Always switch on the dust collector first!

3.8 Hydraulic safety

- a) Make sure all hydraulic hose connections are tightened and there is no leakage of oil.
- b) Over-tightening could damage O-rings. If a leak still persists, remove fitting and replace O-ring.
- c) Make sure the hydraulic hoses have no damages, signs of wear and tear or other defects.
- d) Hydraulic fluid under pressure is dangerous and can cause serious injury.
- e) Hoses and pipe work can be under high hydraulic pressure. The temperature can be above 37° C.
- f) The system runs at or below 170 bar. Never look for a leak when the unit is under pressure.
- g) Avoid leaks by keeping fittings and hoses tight, only check and service when not under pressure.
- h) Leaking hydraulic fluid is not only unsightly, it's dangerous. It could make workplace floors slippery, contaminate the environment and could create a possible fire/explosion hazard.
- i) Never change the oil pressure of the machine! Changing the oil pressure could cause serious damage to the machine and could result in very dangerous situations!
- j) Only work with the hydraulic oil in an area that is well-ventilated, otherwise you must wear suitable respiratory protection. Always wear Personal Protective Equipment when handling the oil:
-Protecting gloves (preferably made of nitrile or neoprene.)
-Safety goggles.
-Hydrocarbon-proof clothing and safety shoes.
- k) Avoid long and repeated contact with the skin, after contact wash thoroughly with water and soap. Contact with eyes: Immediately flush eyes with cold, fresh water for a minimum of 15 minutes. Seek professional medical attention.
- l) Do not eat, drink or smoke near the hydraulic oil.
- m) HV46 hydraulic oil holds no danger of intoxication.
- n) The hydraulic oil is stable at normal temperatures for storage, handling and use. However, the hydraulic oil is flammable when exposed to certain conditions; Empty containers may contain flammable or explosive



vapors. Rags that are soaked with the product and paper or materials which have been used for absorbing the spilled product are inflammable. Make sure that no accumulation occurs. Remove safely after use.

- o) Avoid sparks, open flames, extremely high temperatures and other sources of ignition.
- p) Please read the Safety Data Sheets for additional information regarding the hydraulic oil.
- q) Level should be half the glass of the level indicator. If you don't see the oil in the indicator, the level is too low. If the level is above the glass, the level is too high.
- r) Only use HV46 hydraulic oil (Part nr. E00481), non-compatible fluids could cause damage to the unit or serious injury.
- s) The hydraulic oil and the filter should be replaced at least annually.
- t) Work on hydraulic equipment or operating materials may only be undertaken by a skilled hydraulic engineer or by trained persons under the guidance and supervision of a skilled hydraulic engineer as well as in accordance with the hydraulic engineering regulations

3.9 Transport safety

- a) Be aware of your surroundings and machine operating level. Do not side hill, do not run on steep incline, this could cause machine to tip over.
- b) The weight of the BMP-4000 is between 1550 and 2000 kg. Use a crane or lift when transporting the machine, use the existing lifting eyes / lugs of the machine.
- c) Before every use check the lifting eyes/lugs and welds for: deformation, damages, cracks, corrosion and wear.
- d) Each lifting lug has a WLL of 1500kg, only lift the machine as shown in the picture below.
- e) When lifting the machine from the ground, always use the lowest lifting speed. The cables must first be tensioned at this speed; they must not be slack when the machine is lifted from the ground.
- f) During hoisting make sure to be at a safe distance from the machine with the most optimal view on the machine and working environment.
- g) Never stand directly below or behind the machine.
- h) When transporting the machine do so in such a manner that damage due to the effects of the use of force or incorrect loading and unloading is avoided.
- i) The lifting eyes/lugs can also be used to fasten the machine on a pallet or during transport.
- j) Always drive backwards when driving up to a ramp or grade, and forwards when driving of the ramp.
- k) Chock wheels for transport and keep control handles in neutral position.
- l) Don't leave the machine unsecured on jobsites.
- m) Always use the handbrake when machine is parked.
- n) Always park the machine on a flat horizontal and levelled surface.
- o) Make sure the electrical cable and dust hose are disconnected between the BMP-4000 and the dust collector.
- p) Store the cleaned and dry machine in a humid free room. Protect the electrical motor from moisture, heat dust and shocks.
- q) Never use the machine for lifting persons or items.
- r) Drive preferably with the wheels folded out, this provides the most stability.



Never allow other persons besides the operator to be transported by the machine.

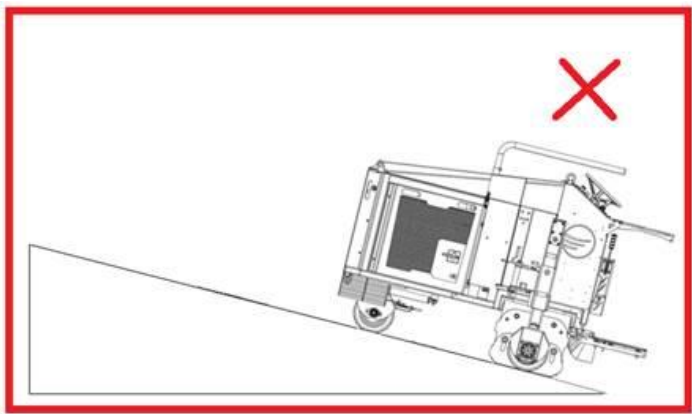
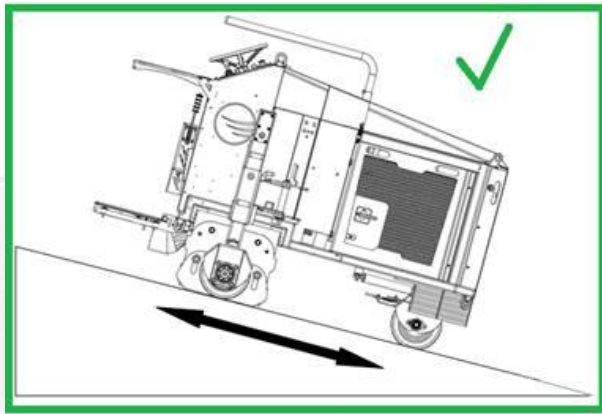
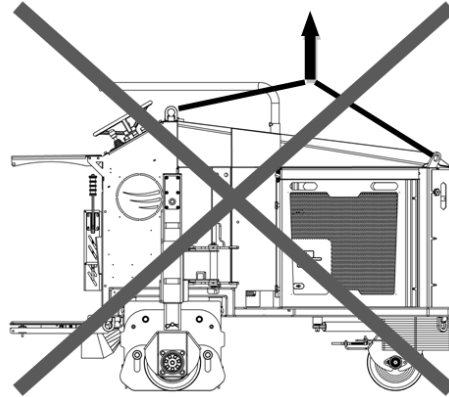
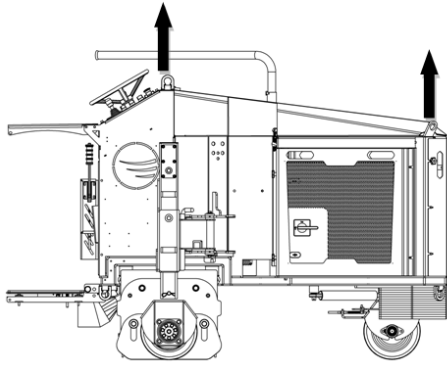



3.10 Signs on the machine

The following stickers are placed on the machine. Meanings of these symbols are:



! Danger Hazardous voltage in motor even when solid state controller is OFF. Disconnect main power before servicing motor, controller or associated wiring.



Lifting point.



No lifting point.



DANGER Rotating parts inside. Keep hands clear. Lock-out / shut down before servicing.



Warning! Hot surface.



Hearing protection and safety glasses are obliged.



Wear a dust mask class FFP3 or higher.



Hearing protection is obliged.



Safety glasses with lateral protection are obliged.



CE-mark on this machine.



Wear protecting gloves.



Safety shoes obliged.



Consult the manual before operating the machine.



No unauthorised person may operate this machine

No unauthorised person may operate this machine.

Type plate:

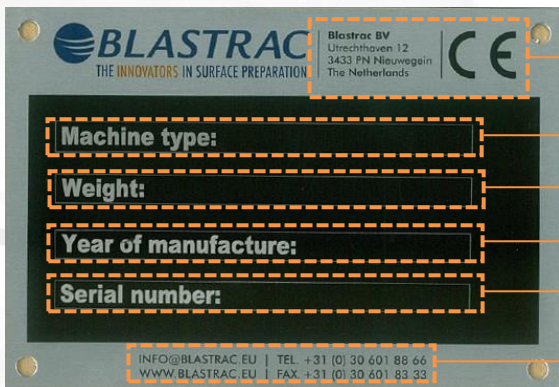

Name, address and CE mark.

The machine type.

The net weight of the machine in kilogram.

The year of manufacture.

The serial number of the machine.

Email address, Website, Telephone & fax number.

EU Declaration of Conformity:





4. Initial operation

Before using the machine it is of great importance to inspect the machine every day. It is not permitted to use the machine if the machine safety is not according the checkpoints below.

4.1 Checkpoints of electrical safety

- Use only extension cables for extending the main cable that are sized and marked in accordance with the overall power consumption of the machine.
- Any damage to electric cables is not permitted and they must be rolled entirely off of the reels.
- Check the cable and plug of the dust collector.
- The main power switch on the machine must be in the "Off" position before connecting to the power supply.
- Always use an electrical power supply connection with earth connection.

4.2 Checkpoints of machine safety

Check if:

- All hydraulic hose connections are tightened and there is no leakage of oil.
- The safety functions and operating functions work correct.
- The drum with picks is in good condition and the picks can turn free in the drum.
- The rubber seals around the drum housing are not damaged.
- There are not any loose nuts or bolts.
- There is not any damage to the dust hose and if it is connected correctly with a hoseclamp and industrial tape.

Work area

- Check the surface to be treated for loose parts (stones, screws, etc.) The surface must be swept if necessary. Make sure the machine can travel over all inequalities on the surface. Small inequalities like weld seams or floor joints are no barriers for the machine.
- Secure the work area around the machine providing an adequate safety distance from the machine. Use a red and white safety chain and danger sign to enclose the work area.
- Remove reinforcing steel or other objects protruding from the surface in order to prevent damage to the machine.
- **Warning! Make sure that the surface to be treated does not contain dangerous materials such as:**
 - combustible or explosive dusts or substances.
 - carcinogenic or pathogenic substances.

In these cases, additional safety measures should be used. Always mind the local safety requirements. Contact your dealer for additional options.

4.3 Removing the drum

- Pull out the main plug before starting removing the drum.
- Always wear protecting gloves and a **dustmask** of at least **class FFP3**.
- Use an additional vacuum cleaner in order to work as dust free as possible.

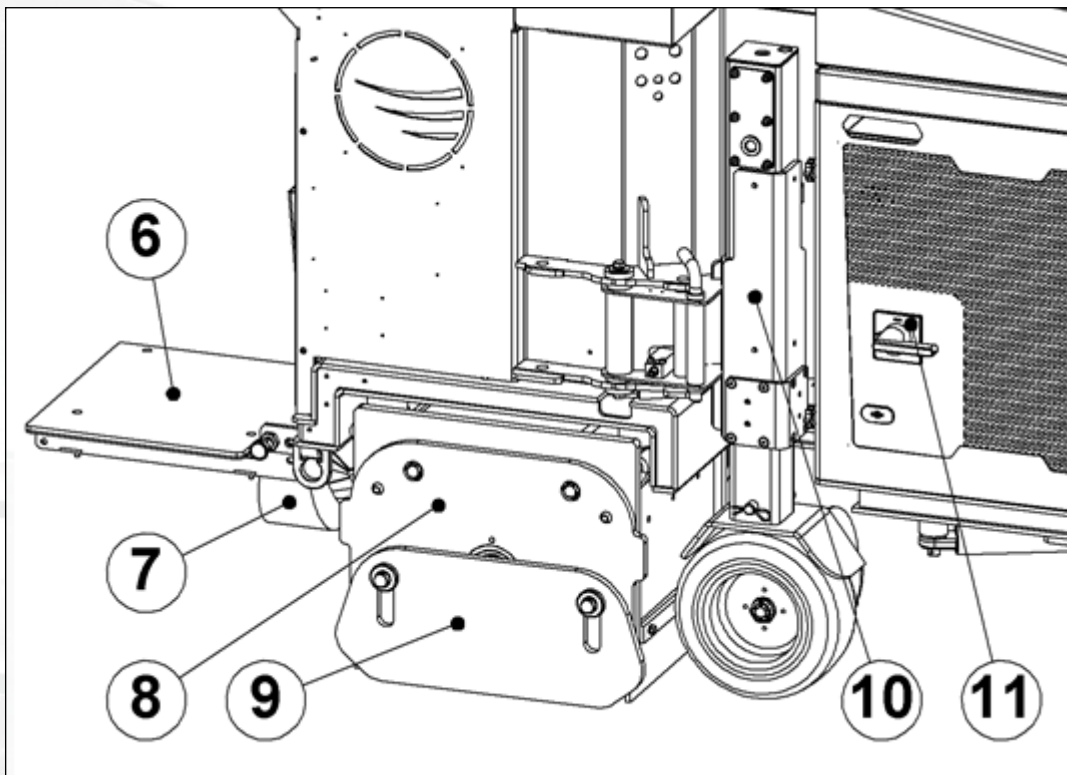

- Always wear a dust mask during these operations, class FFP3 or higher.
- Fold the right wheel (10) in. (see chapter 5.5 how to fold in the wheels)
- Remove the right hand slide plate (9).
- Loosen the bolts of the side plate (8) and remove it.
- Use a pallet truck with the metal plate of the E08965 – Drum changing kit, and position it underneath the drum.

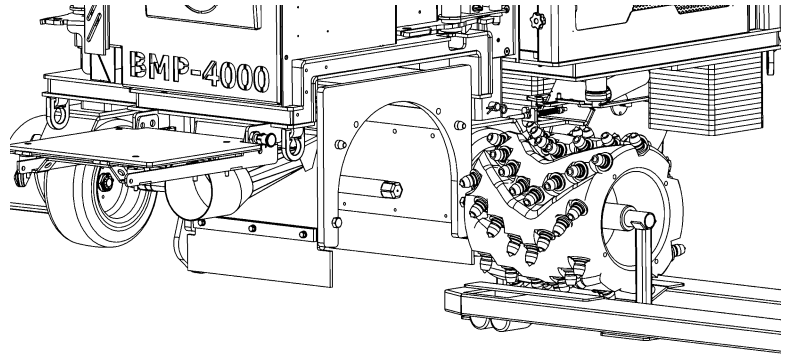
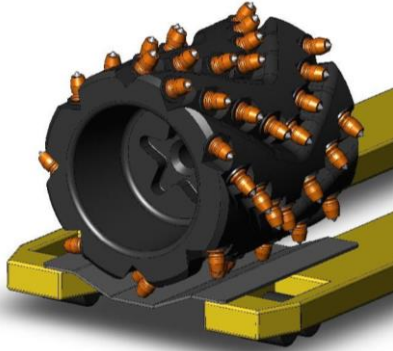

- Lift the pallet truck so the drum will be supported by the pallet truck.
- Mount a rope on the two eyes which are mounted inside the drum.
- Pull the drum from the axle, and support the drum.

4.4 Changing picks on the drum

- Lift the pallet truck up and put the drum on the drum supports.
- Use the pick tool to take out the picks and use a (bronze) hammer to put in the new picks.
 - Clean the pick holes with a vacuum cleaner if necessary.
- It is important that the picks can keep turning around their axles inside the drum, this helps the picks to wear off even. If the picks wear off uneven they will have to be replaced sooner.
- The picks for concrete E07777 have a round point and
- The picks for asphalt E07766 have a hexagon point.



Pick changing tool

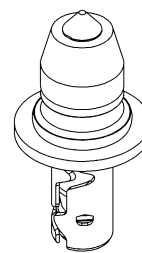

E07777

Concrete

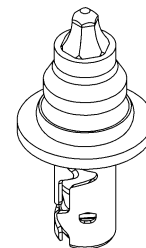

E07766

Asphalt

4.5 Mounting the drum

- Clean the hexagon axle and the hexagon support inside the side plate.
- Position the drum in front of the axle.
- Make sure the axle and drum are at the correct height and slide it back in the machine.
- Mount the side plate and right hand slide plate.

Warning! Never use the machine without a side plate or with an incorrect mounted side plate!

5. Operating BMP-4000

Main screen

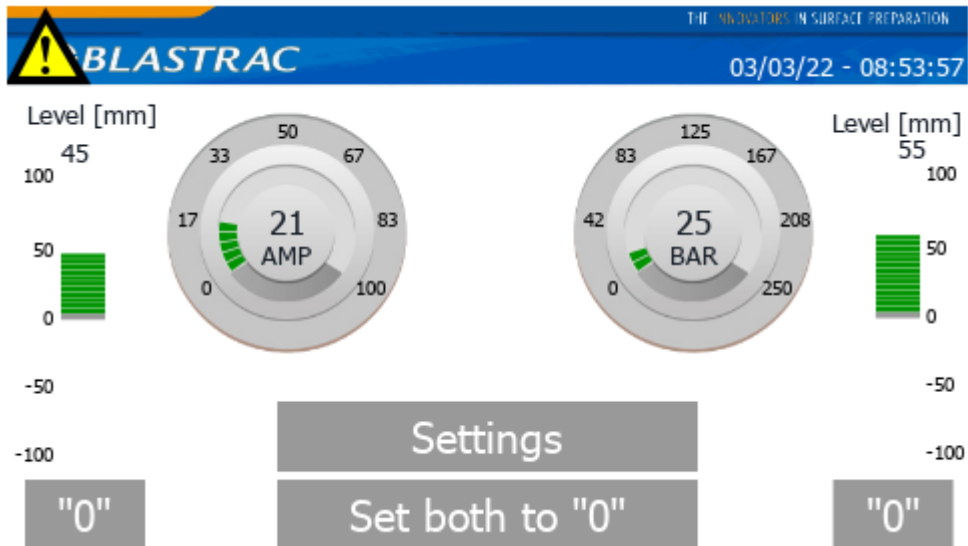

The main screen is showing on the sides the level meters (the relative height of the legs) below this is a button to set a leg to "0".

The two gauges are showing the main motor current and pressure.

With the "Set both to 0" button both the leg level meters are set to 0.

With the Settings button the settings page opens.

The alarm triangle in the left top is showing if there is an alarm or warning, by pressing it an alarm page is loaded.

The right top is showing the date and time.



Settings screen

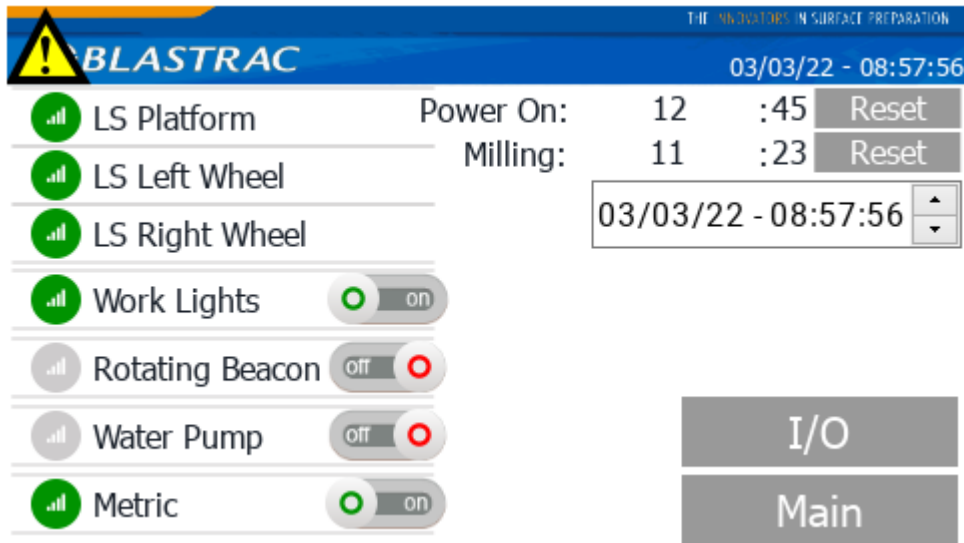

On the left side top down:

- LS platform (switch on the man platform, green when person is present)
- LS Left wheel (switch on the left wheel, green in working position)
- LS right wheel (Switch on the right wheel, green in working position)
- Work lights indicator and switch
- Rotating beacon indicator and switch (this is only a relay switching)
- Water pump indicator and switch (this is only a relay switching)
- Metric indicator and switch (to switch between metric and imperial units and notations)

On the right side top down:

- Power on timer with hours and minutes shown, with the reset button the timer can be set to 0
- Milling timer with hours and minutes shown, with the reset button the timer can be set to 0
- Date time editor, here can the date and time be edited.
- I/O button, with this button the main In- output page is loaded
- Main Button, with this button to the main screen



Alarm screen

BLASTRAC		
Select	Description	Time
<input type="checkbox"/>	Emergency stop active	3-3-2022 09:26:16

Check/Uncheck All Acknowledge Main

This page is showing the alarms every alarm is shown as follows:

- Select box, the alarm can be selected in order to acknowledge. An alarm can be selected by pressing the box or the Check/Uncheck all button
- Description, the name of the alarm
- Time, the date and time this alarm occurs.

With the acknowledge button the selected alarms are acknowledged.
The main button loads the main page.

Most common alarms:

Thermal Failure Motor will light up red when the thermal protection of the motor is activated.

Thermal Failure Fan will light up red when the thermal protection of the fan is activated.

E-Stop Active will light up red when: the emergency stop button is pushed in, or when the contact key is turned in the OFF-position, or when the dead man's switch is pulled out.

Oil Level too Low will light up when the hydraulic oil level is too low.

Oil Temp. too High will light up when the temperature of the hydraulic oil is too high for safe operation.

Phase Seq. Fault will light up red when the phase sequence of the power supply is not correct.

PhotoCell Error / LS platform will light up red when there is no one on the platform. Driving and/or milling will not be possible.



IO pages

THE INNOVATORS IN SURFACE PREPARATION
03/03/22 - 09:42:26

Thermal failure main motor <input type="checkbox"/> Main Motor running <input type="checkbox"/> Level alarm <input type="checkbox"/> Temp end alarm <input type="checkbox"/> Thermal failure motor cooler <input type="checkbox"/> EM-stop activated <input type="checkbox"/> Phase failure <input type="checkbox"/> Limit switch man <input type="checkbox"/> LS left wheel <input type="checkbox"/> LS right wheel <input type="checkbox"/> Spare <input type="checkbox"/> Spare <input type="checkbox"/> Spare <input type="checkbox"/> Spare <input type="checkbox"/> Spare <input type="checkbox"/> HCX drive speed 0 <input type="checkbox"/> Spare 0 <input type="checkbox"/>	HCX drive forward <input type="checkbox"/> HCX drive reverse <input type="checkbox"/> HCX milling forward <input type="checkbox"/> HCX milling reverse <input type="checkbox"/> Start 11M1 <input type="checkbox"/> Start 12M1 <input type="checkbox"/> Spare <input type="checkbox"/> Bridge EM-stop <input type="checkbox"/> Spare <input type="checkbox"/> Spare <input type="checkbox"/> Lenght measurement left 0 <input type="checkbox"/> Lenght measurement right 0 <input type="checkbox"/> Main motor current 0 <input type="checkbox"/> Main pump pressure 0 <input type="checkbox"/>	Water pump <input type="checkbox"/> Rotarie beacon <input type="checkbox"/> Work lights <input type="checkbox"/> Horn <input type="checkbox"/> Invert left wheel <input type="checkbox"/> Takeover steering <input type="checkbox"/> Steer left <input type="checkbox"/> Steer right <input type="checkbox"/> Spare <input type="checkbox"/> Spare <input type="checkbox"/> Spare <input type="checkbox"/> Spare <input type="checkbox"/> Spare <input type="checkbox"/> BlastSense power on <input type="checkbox"/> BlastSense working <input type="checkbox"/> BlastSense Error <input type="checkbox"/>
--	--	--

Console IO Remote Settings

THE INNOVATORS IN SURFACE PREPARATION
03/03/22 - 09:43:13

Switch local <input type="checkbox"/> Switch remote <input type="checkbox"/> Joystick forward <input type="checkbox"/> Joystick reverse <input type="checkbox"/> Milling <input type="checkbox"/> Drive <input type="checkbox"/> Milling forward <input type="checkbox"/> Milling reverse <input type="checkbox"/>	Milling speed 1 <input type="checkbox"/> Milling speed 2 <input type="checkbox"/> Milling speed 4 <input type="checkbox"/> Milling speed 8 <input type="checkbox"/> Joystick 0 <input type="checkbox"/> Start <input type="checkbox"/> Stop <input type="checkbox"/> Pump Running <input type="checkbox"/>
---	---

Remote Cabinet Settings

THE INNOVATORS IN SURFACE PREPARATION
03/03/22 - 09:43:47

Start <input type="checkbox"/> Stop <input type="checkbox"/> Milling forward <input type="checkbox"/> Milling reverse <input type="checkbox"/> Drum <input type="checkbox"/> Milling <input type="checkbox"/> Drive <input type="checkbox"/> Spare <input type="checkbox"/> Milling speed 1 <input type="checkbox"/> Milling speed 2 <input type="checkbox"/> Milling speed 4 <input type="checkbox"/> Milling speed 8 <input type="checkbox"/> Joystick forward <input type="checkbox"/> Joystick reverse <input type="checkbox"/> Joystick left <input type="checkbox"/> Joystick right <input type="checkbox"/>	Remote on <input type="checkbox"/> Remote hold <input type="checkbox"/> Remote horn <input type="checkbox"/> Remote pairing <input type="checkbox"/> Remote watchdog <input type="checkbox"/> Remote Tilt <input type="checkbox"/> Remote led 1 <input type="checkbox"/> Remote led 2 <input type="checkbox"/> Remote buzzer 1 <input type="checkbox"/> Remote Buzzer 2 <input type="checkbox"/> Remote vibrator <input type="checkbox"/> Remote red screen <input type="checkbox"/> Remote paring <input type="checkbox"/> Remote drive active <input type="checkbox"/>	Joystick Fwd/Rev 0 <input type="checkbox"/> Joystick Left/Right 0 <input type="checkbox"/> Spare 0 <input type="checkbox"/> Spare 0 <input type="checkbox"/> Oil pressure 0 <input type="checkbox"/> Motor current 0 <input type="checkbox"/>
---	---	--

Console IO Cabinet Settings

The IO pages are showing the in- and outputs in the cabinet (1st figure) the Console (2nd figure) and the remote (3th page).



Controls

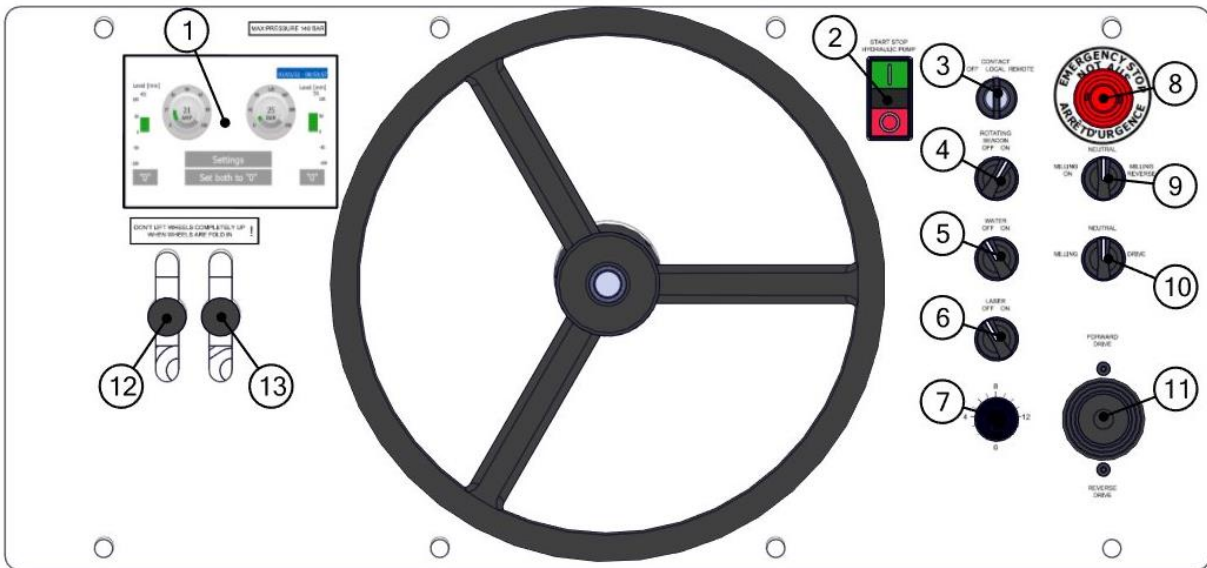

1	Control panel
2	Hydraulic motor ON/OFF
3	Contact with key OFF / LOCAL / REMOTE
4	Switch for rotating beacon ON/OFF (optional)
5	Worklight ON/OFF (optional)
6	Water pump ON/OFF (optional)
7	Driving speed selection button (1-10)
8	Emergency stop button
9	Switch for milling motor: MILLING ON/NEUTRAL/MILLING REVERSE
10	Switch for operating mode: MILLING/NEUTRAL/DRIVE
11	Joystick for driving forward/backwards
12	Left Hand back wheel UP/DOWN
13	Right Hand back wheel UP/DOWN
14	Electric cable guide
15	Electro box with main switch
16	Operator platform with safety switch
17	Dead mans switch
18	Leveller

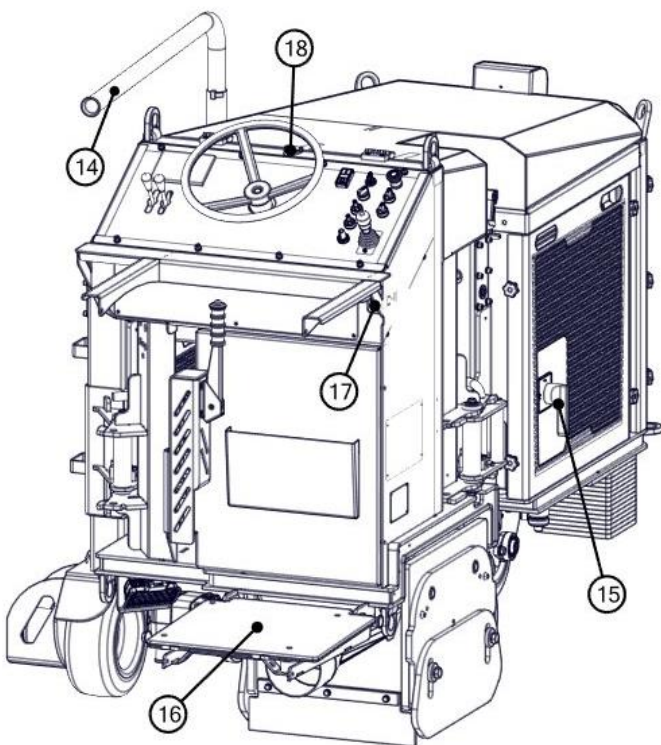



During operating the BMP-4000, the following additional safety instructions must be followed closely.

5.1 Switching on the machine

- Connect the machine with the power supply. (14)
- Turn on the main switch (15) on the side of the machine.
Check the display (1) on the control panel for alarms.
-The machine won't start if the line "Phase Seq. Fault" is indicated red.
- If there is a phase incorrect, make sure this will be changed.
-Never change anything on the plug, cable or electrical box of the BMP-4000.

- If there is no "Phase Seq. Fault" u can take place on the operator platform (16)
-The platform is fitted with a safety switch so there is no milling and driving possible when there is no one on the platform. (except in RC-mode).
- Attach the cord of the deadman switch (17) to your arm or clothing.
- Pull out the emergency switch (8)
- Turn the key contact switch (3) to the right.
- Push the green "Start" button (2)
- Wait till the motor is running at nominal speed.

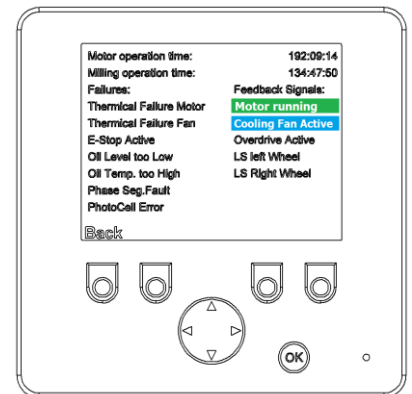

5.2 Leveling the machine (without milling)

1. Make sure the machine is always in a levelled position. You can see this by checking the leveller (18) on top of the operating panel.
2. To level the machine, you can use both handles (12) & (13).
-Always lift and lower the machine carefully and with low speed.
3. Make sure the switches (9) (10) and the joystick (11) are in the middle position.

(9) "Milling on / - / Milling Reverse"

(10) "Milling / - / Drive"

(11) "Forward / - / Reverse drive"

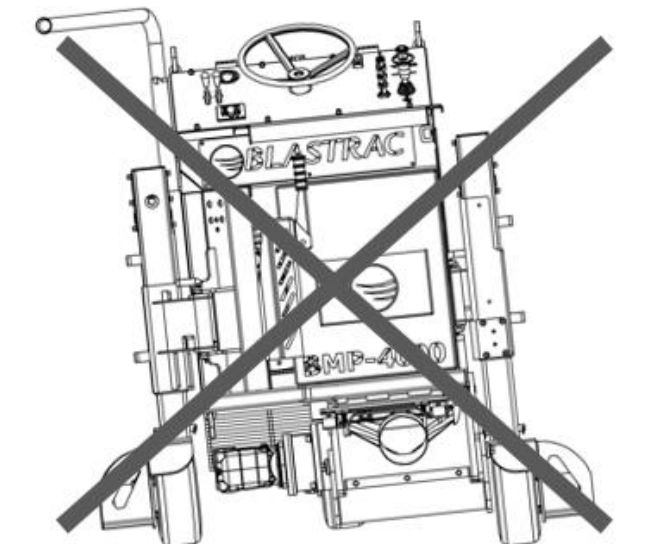



5.3 Driving the machine (without milling)

4. Make sure there are no other people in an area of 5 meters around the machine.
5. Turn switch (10) to "Drive" so you can only drive with the machine.
-In this position the milling drum cannot turn.
6. By using the joystick (11) you can drive forward and backward. Before u can use the joystick the bottom part has to be squeezed in, this is a safety device against unintentionally actuating of the machine.
 - a. Use the joystick very carefully and slowly.
7. The further the joystick is forward or backward, the faster the machines goes.
 - a. The "Speed" button (7) does not work when the machine is in "Drive" mode.



5.4 Working with the machine

- Make sure the drum is off the surface and the machine is levelled.
- Turn switch (10) from "Drive" to "Milling".
- Turn switch (9) to "Milling ON" and wait for a few seconds to start up the drum
- Set the "Speed" button (7) on "1"
 - The "Speed" button helps you to set the maximum speed. 1 is a low maximum speed and 12 is high maximum speed.

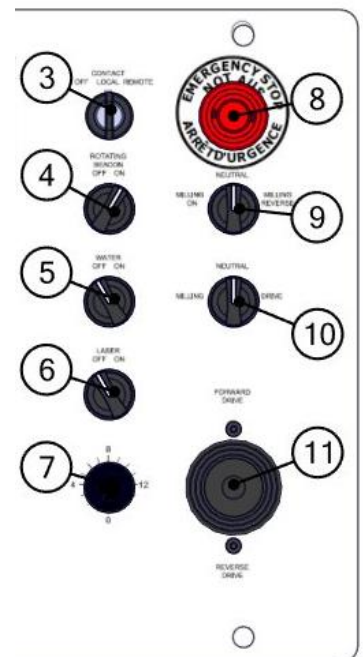

- Lower the machine carefully with both handles (12) & (13) make sure the machine stays in a levelled position.
- Lower the machine until you hear the picks hitting the floor. Make sure the machine is levelled!
- Push the left "Set both to 0" button on the display (1) to set the height measurement of the cylinders to 0.
- Now lower the machine slowly to the essential depth, use both handles (12) & (13) to keep the machine levelled.
 - Don't try to take away too much in one pass, it is better to do more passes.
- If the depth is set, push the joystick slowly to the front. The right side of the machine is in the same line as the pattern of the drum, so you can follow this line to have a good milling pattern with having just a very small overlay with your previous line.

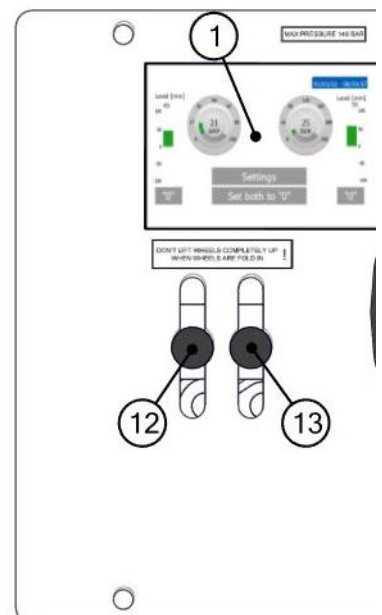



- If the driving speed is too low, you can set the "Speed" button(7) to 2, 3 or even higher.
- If you are almost at the end of your milling line, lower the driving speed.
- At the end of your line, stop driving and lift the machine with both handles (12) & (13) so the drum is lifted from the surface.
- Stop the drum by turning the "Milling" switch (9) to the middle position.
- If you can drive forward, you drive with the joystick.
- If you want to go backwards, you first have to change switch (10) from "Milling" to "Drive".
 - This is always the best and safest way to drive with the machine.

5.5 Folding in the wheels

Both wheels can be folded in. The right hand wheel, so the machine can be closer to the wall and the left hand wheel to change the hydraulic motor or to go through small passages. Milling is not possible when the left hand wheel is folded in.

Right hand wheel:

- To fold in the RH wheel, lower the machine in levelled position until the drum supports on the surface.
 - Use both handles (12) & (13)
 Lift the right wheel up till the end (handle 13)
- Take out the pin, turn the wheel inside and put the pin back in.
 - Be careful with all the hoses and check if the hoses and cables are not stuck between the frame.
- Lower the RH wheel (handle 13), so the machine will be lifted.
 - Notice that the right side will lift faster now the wheel is more to the front.

If there is no drum underneath the machine when you want to fold in the right hand wheel, you can use Support Bracket - E14207 to support the machine on.

Left hand wheel

- To fold in the left hand wheel, put Support Bracket - E14207 underneath the frame or the hydraulic motor to support the machine so the left wheel can be free of the surface.
- Lower the machine until it rests on Support Bracket - E14207.
 - Use both handles (12) & (13)
 Lift the left wheel up till the end (handle 12)
- Take out the pin, turn the wheel inside and put the pin back in.
 - Be careful with all the hoses and check if the hoses and cables are not stuck between the frame.
- Lower the LH wheel (handle 12), so the machine will be lifted.

5.6 Tips for milling and working with the machine

- The best way to work is to start at the right side and then work from right to left, so you can use the side of the machine with your previous line.
- Put the dust hose and electric cable to one of the legs with a small chain or rope, this will help to guide the hose and cable away from the wheels of the machine during work.
- Start every job with milling off just a few mm, this to check the surface and the way the machine responds to it.
- Try to stay with one of the wheels on a flat surface, so you only have to adjust one side of the machine to stay levelled during milling.
- If possible, always work with both wheels folded out.
- When the left wheel is folded in, there is no possibility to mill with the machine. This option is only there to easily change the drum motor and to go through small passages.
- Check if the picks in the drum still can rotate around their own axle. If the picks are stuck in the housing, the picks wear off uneven. Which means they will have to be replaced sooner.
- Make sure the pressure during milling is not higher than 100 bar. When the machine is turning free, 30 bar is a normal pressure.



5.7 Remote Control

Working the BMP 4000E with the Radio Remote:

1. Turn on the machine with the main switch located in the door of the electrical cabinet



2. Pull the emergency stop when pressed (located on the dashboard).



3. Turn the key switch to the position "remote" (located on the dashboard)



4. Now the system is ready to enable the remote control



5. To enable the remote you need to pull the emergency stop and after that push twice the horn button, a buzzer will sound. Now the system is enabled. When you now push the start button you start the hydraulic system.



Emergency stop Enable remote Start/stop Hydraulics

6. Driving the machine without the drum on.
Set the selector switch
To "DRIVE"



Now you can drive the machine with the Joy-stick





7. Operating the machine with the drum on.
Set the selector switch to "MILLING"



Start the drum by pressing the Button "DRUM" a second push of the button will stop the drum.



Choose with the selector switch if you want to go "FWD" or "REV" (also possible during milling)



With the pot. meter you can choose the driving speed. The machine will start driving only when the switch is started from 0 or passes the 0.

This to prevent that the machine starts an uncontrolled drive.



Ready for speed setting



For start driving first go to 0 and then the system is ready for speed setting

8. When ready with work push the button "STOP" and then the EM-stop on the remote.



Start/stop Hydraulics Emergency stop

9. Turn the key switch to the position "OFF" (located on the dashboard)



10. Push the emergency stop (located on the dashboard).



11. Turn off the machine with the main switch located in the door of the electrical cabinet





6. Maintenance

Pay attention to Chapter 3 "**Safety**" during maintenance and repair works.

Failures due to inadequate or incorrect maintenance may generate very **high repair costs** and long standstill periods of the machine. **Regular** maintenance therefore is imperative.

Operational safety and service life of the machine depends, among other things, on proper maintenance.

Prevent premature wear by keeping the machine as dust free as possible. Clean the machine for this reason regularly with a dust collector.

The following table shows recommendations about time, inspection and maintenance for the normal use of the machine.

Operating hours/ time period	Inspection points, maintenance instructions
12 h after repairing	Check all accessible screw connections for tight seat.
Daily and prior to starting work	Check that all safety devices working adequate. Check for loose bolts and loose hydraulic connections. Check the cables and hoses for leakage, wear and tear. Check the electric connections for sediments of dirt or foreign bodies. Check the seals around the drum housing.
After each workday	Protect the ignition lock against dirt and moisture. When the starting key is pulled out, seal the ignition lock with the protective cap.
Monthly	Greasing the bearings in the drum house
Annually	Full overhaul and cleaning of the complete machine.

Due to different working conditions it can't be foreseen how frequently inspections for wear, check's, inspection, maintenance and repair works ought to be carried out. Prepare a suitable maintenance schedule considering your own working conditions and experience. However a full overhaul must be carried out at least once a year.

Our specialists will be happy to assist you with more advice.

Prior to any repair works on the machine and its drives, secure the machine against unintentional switching on. Put the machine to its safety off position.

Follow additional operating and maintenance instructions of Original Equipment Manufacturer during your service and maintenance work. (For example the laser-levelling system)

Further is advised:

Clean the machine with a dust collector and non-aggressive materials. Never use a high pressure water cleaner to clean the machine.

Store the cleaned and dry machine in a dry and humid free room. Protect the electrical motors from moisture, heat, dust and shocks.

All repair work must to be done by qualified Blastrac personnel, this to guarantee a safe and reliable machine.

Any guarantee on the machine is expired when:

- Non original Blastrac parts have been used
- Repair work is not done by qualified Blastrac personnel
- Changes, add on's or conversions are undertaken without written permission of Blastrac BV



6.1 Changing of hydraulic motor and checking coupling buffer

To check the buffer of the milling axle coupling, the hydro motor should be taken off.

- Fold the left wheel in (1) and loosen the hydraulic hoses from the motor (3)
- Unscrew the 4 bolts (2) so the motor with flange and coupling can be taken off.
- Check the buffer (4) and replace if necessary. (Part number E07782)
- Check the seals (5) around the drum housing for any damages.

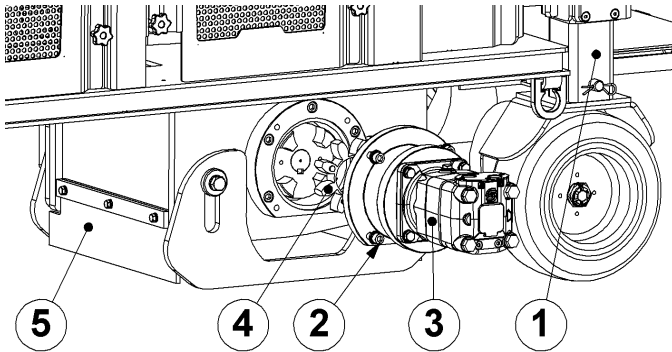

Coupling buffer
Part number E07782

6.2 Maintenance of bearings

Both bearings in the drum housing are open bearings which are covered by special designed shaft seals.

These bearings should be greased to keep the dust out of the bearings.

By normal daily use the bearings should be greased once a month.

The quantity of used grease should be 5-10 gram. This is equal with 2-6 pumps of grease (on points 6 & 7)
Be careful! Too much grease is not good for the bearings!

Only use the grease which is recommended by Blastrac, this is E08729 – bearing grease.
This grease is specially made for this kind of application. Using other grease will damage the bearing.

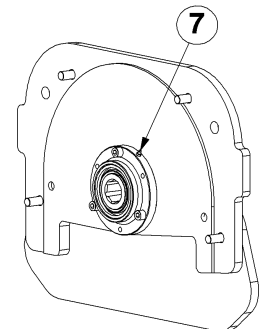
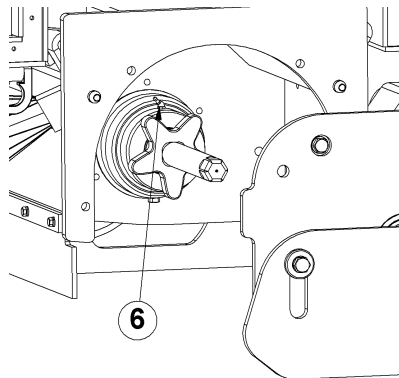



6.3 Replacing the shock absorbers

The drum housing has 6 shock absorbers designed for heavy duty operation. Excessive vibrations could indicate worn out shock absorbers. The replacement interval depends on the work that has been carried out, as a rule we advise to replace them at least annually.

Use the handles (1.) to let the machine down as far as possible so it will stand on the **drum** and the 3 wheels (2).
Remove the back cover (3).

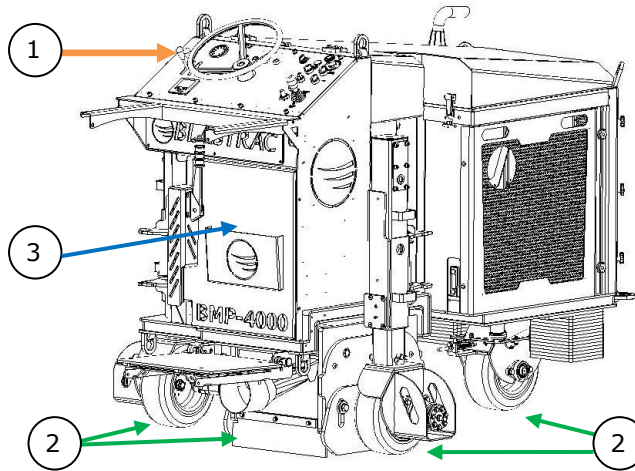

Use a socket wrench with flexible extension (4) to remove the six nuts of the shock absorbers on the inside of the frame (5).

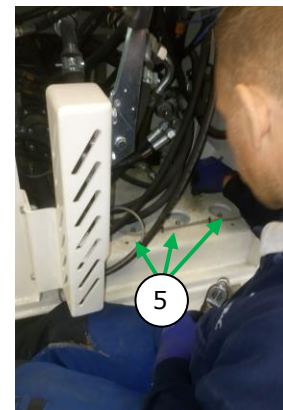

Slowly lift the machine up to its maximum horizontal position.
Now the old shock absorbers can easily be replaced for six new shock absorbers (6).

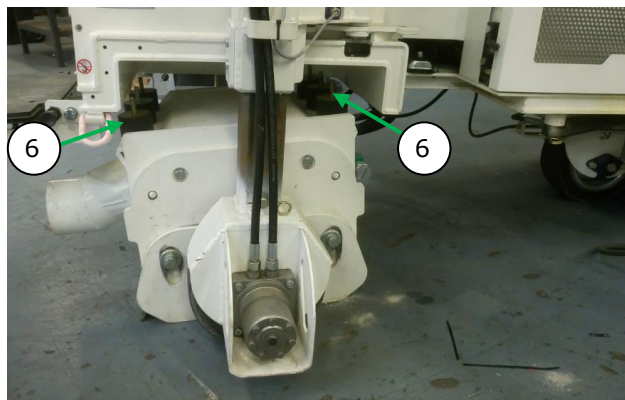

Partnumber	Item
RB270A/9	Shock absorber



Slowly and carefully let the machine down.

Use a pallet truck (7) and crowbar (8) to align the shock absorbers with the holes in the frame.

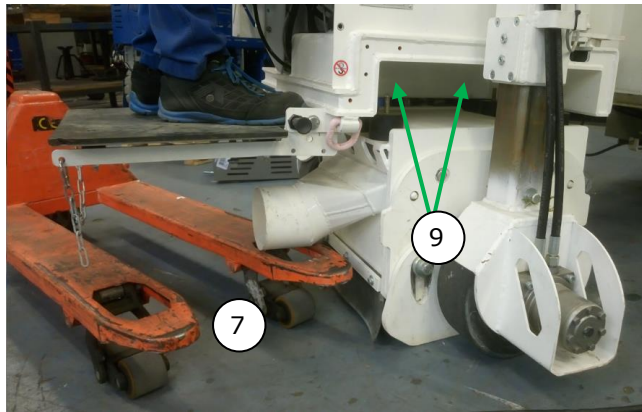

Make sure all nuts + spring washers + washers are tightened properly.



7. Troubleshooting

Fault	Possible cause	Remedy
Excessive vibration or/and Unusual noises	Imbalance due to worn or broken tools. Defective bearing. Wrong tension of the belt. Defective motor. The scarifying setting is too deep.	Replace all worn or broken parts. Check the bearing on the axle drive shaft and replace if necessary. Check the tension of the belt, replace the belt if necessary. Replace the motor. Reduce the scarifying depth.
Reduced or no scarifying performance	Tools have reached the maximum permissible wear. Inappropriate tools for the application.	Replace the worn parts. Replace the tools with appropriate tools for the surface to be treated.
Motor does not switch on	Missed phase. Wrong phase. Defective Component. Dead man's switch is activated.	Check the mains power supply and try to switch on again. Adjust phase. Find fault and replace defective component. Put the key of the dead man's switch in.
Motor protection switch triggers while running	Motor protections switch triggered because of overload . Motor has a defect.	Reduce the scarifying depth. Check the motor.

8. Technical data

	BMP-4000E RC 3x400V		
Power consumption	30 kW		
Electrical connection / fuel	3x 400 volt		
Frequency	50Hz		
Power connection	5 pole / 63 ampere		
Working width	390 mm		
Rotation speed drum	300 min ⁻¹		
Working speed	0-45 m/min		
Drive speed	0-2,7 km/h		
Length	1995 mm		
Width	840/1190/1512 mm		
Height	1660 mm		
Weight	1550 kg (excl. drum)		
Noise level	Up to 98,5dB(A)		
Dust hose connection	Ø150 mm		
Power generator	52 KVA		

Design and specifications are subject to change without notice by Blastrac BV.
The electrical diagrams of the electrical system are placed inside of the control panel.

**Vibration level:**

Measured; 2,15 RMS (ISO 5349) (Hand-arm vibration on steering wheel)

This measure allows working continuously with the mentioned equipment without having to use anti vibration precaution measures for 10,8 hours.

Measured; 0,284 RMS (ISO 2631) (Whole-body vibration on standing platform)

This measure allows working continuously with the mentioned equipment without having to use anti vibration precaution measures for 24,8 hours.

IMPORTANT NOTE:

Vibration levels can vary in different circumstances. The indicated value was measured on a new machine. The surface to be treated, the depth of milling, the speed of driving etc. will give different values at all time.

Noise level: (under load)

98,5dBa

IMPORTANT NOTE:

Sound levels can vary in different circumstances.

The indicated value was measured on a new machine.

Area influences like open outside or closed inside space, the surface to be treated etc. will give different values at all time.

Hearing protection is required with the use of this equipment.

Old equipment contains valuable materials which are valuable for re-processing. The machine parts must not be thrown away in the normal household waste, but should be disposed of at a suitable proper collection system, e. g. via your communal disposal location. This way the materials can be re-used in an environmentally responsible manner.

Dispose of the machine (including machine parts, engine oil and fuel) according to the local disposal regulations and the environmental laws in the country of use.

Because of the danger of possible environmental damage, only permit an approved specialist company to dispose of the machine.

The original operating instructions are in the English language, any other language is a translation of the original version.

Despite the fact that this guide is made with care, Blastrac takes no liability for errors in the manual and the possible consequences. We are naturally very interested in your findings and additions.

No part of this publication may be reproduced and / or published in print, photocopy, or other form without prior permission by Blastrac.



Headquarter

Blastrac The Netherlands

Utrechthaven 12
 NL – 3433 PN Nieuwegein
 Tel – 0031 30 601 88 66
 Fax – 0031 30 601 83 33
 Info@blastrac.nl

Blastrac Poland

Golina, Dworcowa 47a
 PL – 63-200 Jarocin
 Tel – 0048 627 40 41 50
 Fax – 0048 627 40 41 51
 Info@blastrac.pl

Blastrac Italy

S.S. 10 Padana Inferiore, 41
 IT – 29012 Caorso (PC)
 Tel – 0039 0523 81 42 41
 Fax – 0039 0523 81 42 45
 Info@blastrac.it

Blastrac United Kingdom

Unit 2, Outgang Lane, Dinnington
 Sheffield, South Yorkshire
 GB – S25 3QY, England
 Tel – 0044 1909 56 91 18
 Fax – 0044 1909 56 75 70
 Info@blastrac.co.uk

Blastrac Germany

Richard Byrd Straße 15
 D – 50829 Köln (Ossendorf)
 Tel – 0049 221 70 90 32 0
 Fax – 0049 221 70 90 32 22
 Info@blastrac.de

Blastrac Spain

Calle Copernico, 16
 Nave 2
 E – 28820 Coslada
 Tel – 0034 91 660 10 65
 Fax – 0034 91 672 72 11
 Info@blastrac.com.es

Blastrac France (ZI)

29, Avenue des Temps Modernes
 F – 86360 Chasseneuil du Poitou
 Tel – 0033 549 00 49 20
 Fax – 0033 549 00 49 21
 Info@blastrac.fr

Blastrac Ukraine

Nezalezhnosti 14, of. 21
 UA – 07400 Brovary
 Tel – 0038 44 222 51 28
 Fax – 0038 44 277 98 29
 Info@blastrac.com.ua