

K1250 Active, 2008-01

SPARE PARTS LIST

L K1250

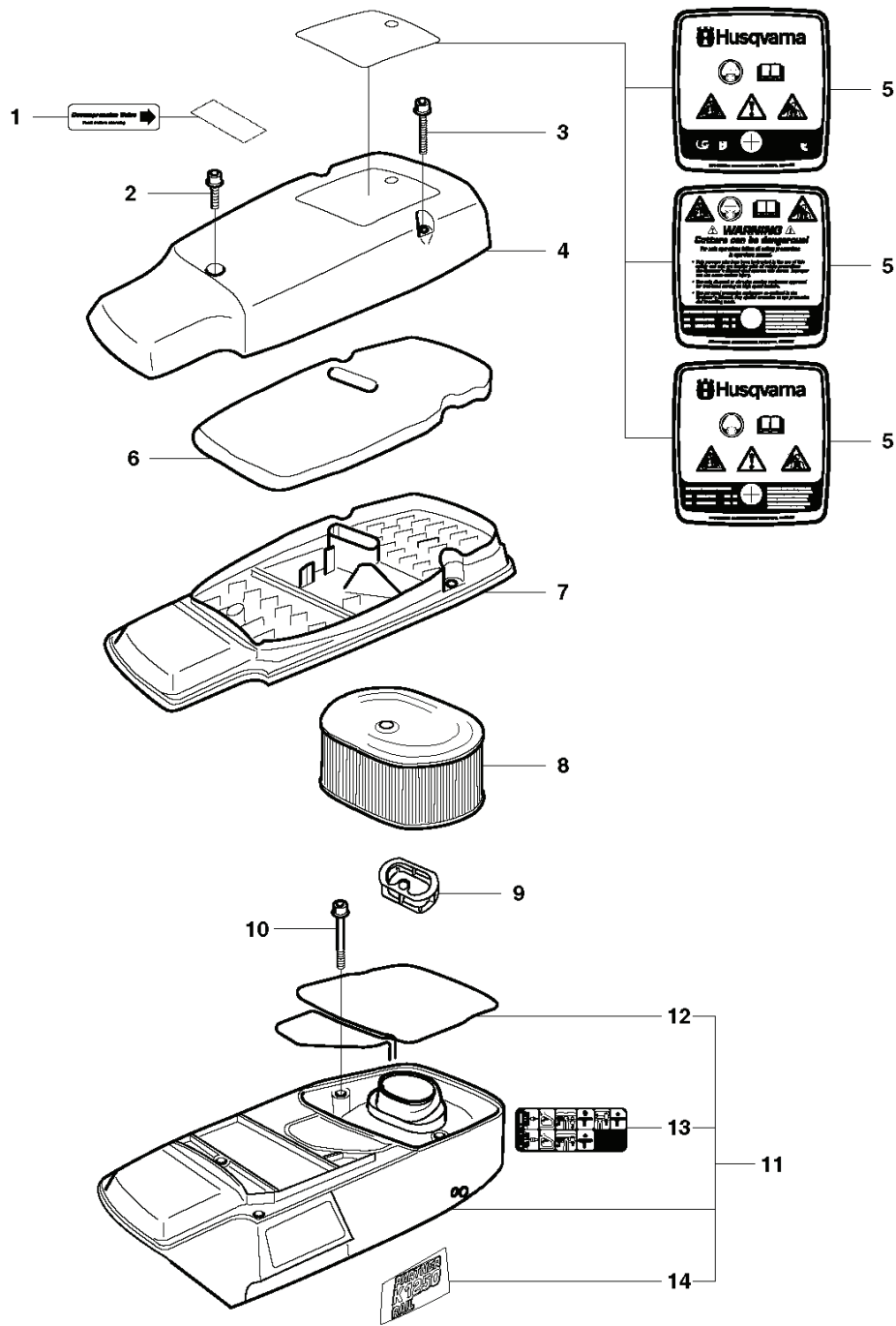

REF.	PART NO.	DESCRIPTION	REMARK	QTY.	KIT
1	544874602	LABEL		1	
2	503203425	SCREW CCRPANMO		1	
3	503203455	SCREW CCRPANMO		2	
4	506255602	FILTER COVER		1	
5	544874402	LABEL		1	
5	544874403	LABEL		1	
5	544874404	LABEL		1	
6	506268701	PREFILTER		1	
7	506255702	FILTER BOTTOM		1	
8	506231803	LUFTFILTER PAPPER		1	
9	506250301	INSERT		1	
10	503200230	SCREW IHSCFM		4	
11	506275402	CYLINDER COVER		1	
12	506283930	SEALING		1	
13	544873801	LABEL		1	
14	544873901	LABEL		1	
14	544873902	LABEL		1	

C K1250

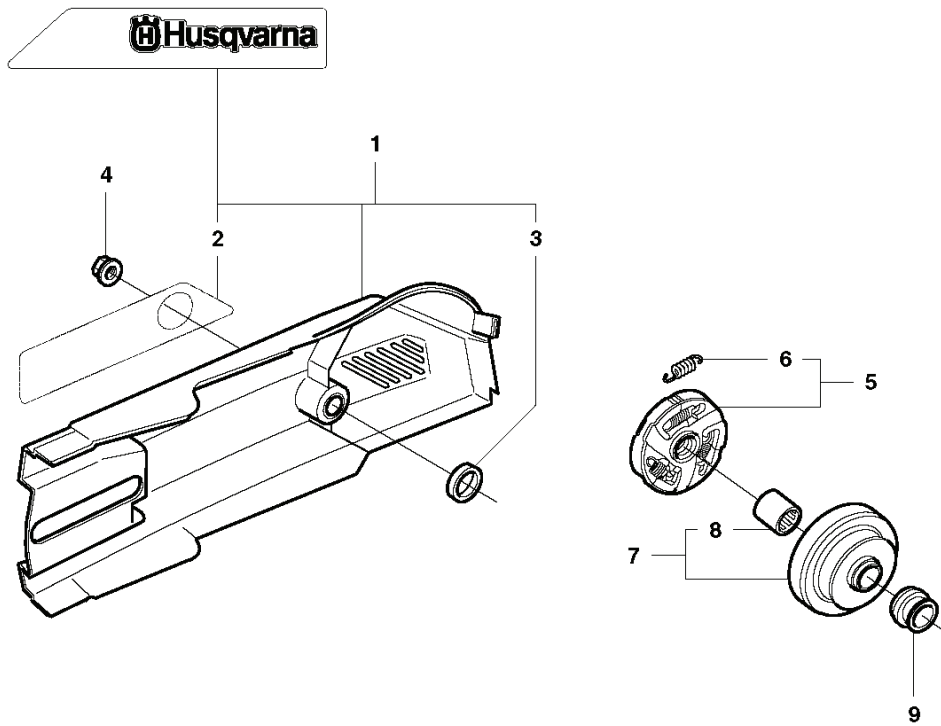

REF.	PART NO.	DESCRIPTION	REMARK	QTY.	KIT
1	506271703	BELT GUARD	Incl. 2, 3	1	
2	544873601	LABEL		1	
3	506268401	SPACING SLEEVE		1	
4	503220001	HEXAGON NUT		1	
5	503144901	CLUTCH ASSY	Incl. 6	1	
6	503145101	CLUTCH SPRING		3	
7	540052801	DRIVING PULLEY ASSY	"14". Incl. 8"	1	
7	540052803	DRIVE SPROCKET	"16". Incl. 8"	1	
7	506254901	GEAR WHEEL ASSY	"Rail 16". Incl. 8"	1	
7	506254903	GEAR WHEEL ASSY	"Rail 14". Incl. 8"	1	
8	503253801	NEEDLE BEARING		1	
9	506285901	SPACING SLEEVE		1	

R K1250
K1250 Rail

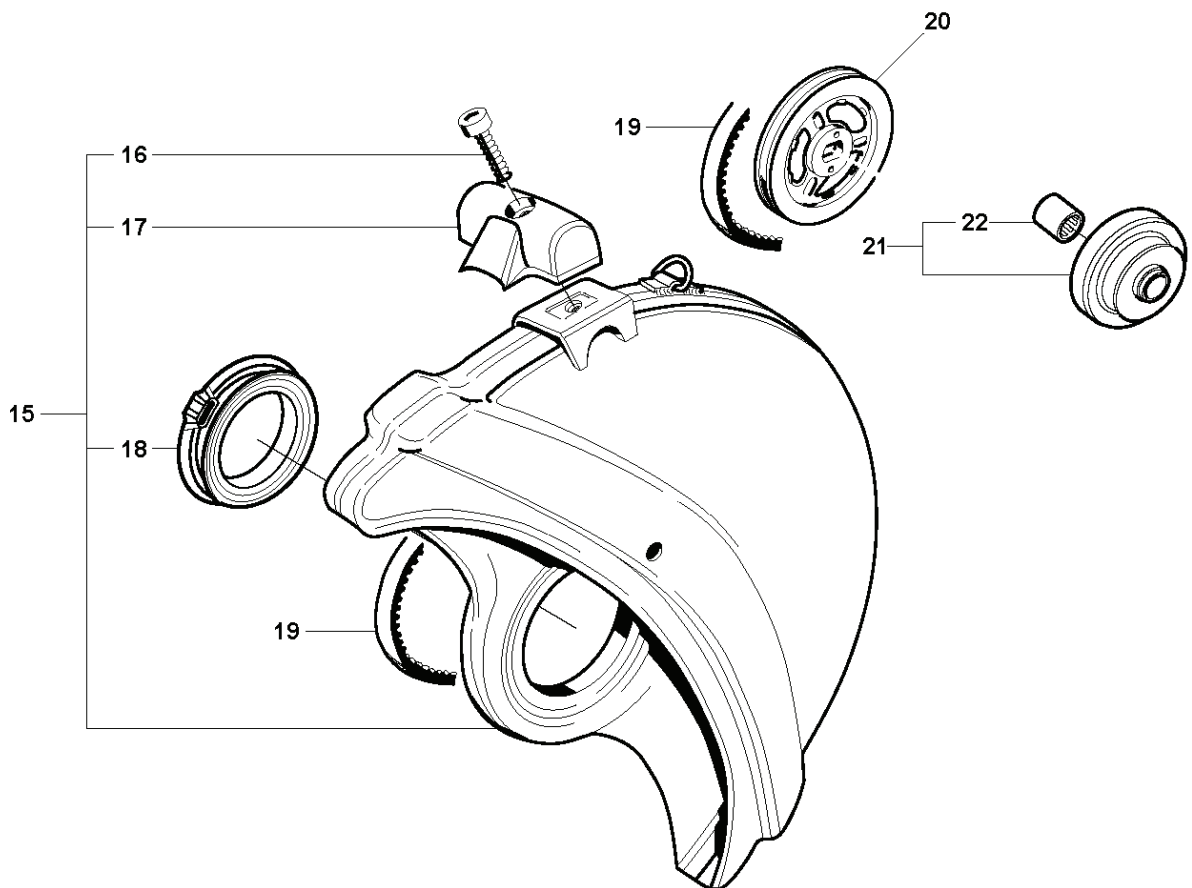
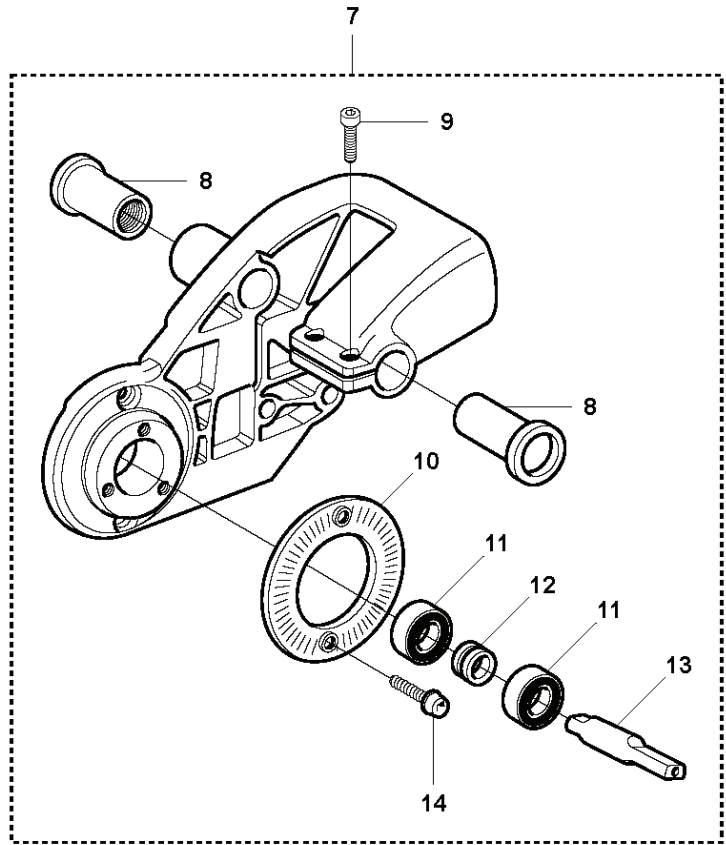
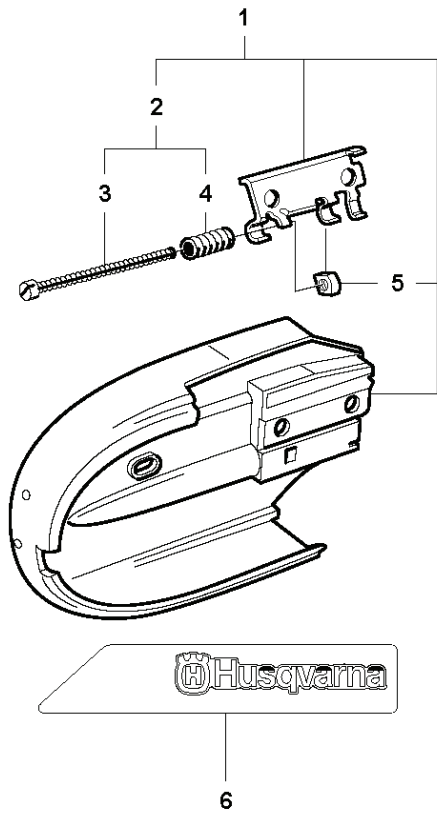

REF.	PART NO.	DESCRIPTION	REMARK	QTY.	KIT
1	506279203	BELT GUARD	"Rail 14", Incl. 2, 5"	1	
1	506279204	BELT GUARD	"Rail 16", Incl. 2, 5"	1	
2	506266603	BELT TENSIONER ASSY	Incl. 3, 4	1	
3	503203011	SCREW SLCHM		1	
4	506266801	COMPRESSION SPRING		1	
5	503226601	SQUARE NUT		1	
6	544873601	LABEL		1	
7	544887501	BEARING HOUSING	"Rail 14", Incl. 8 - 14"	1	
7	544887503	BEARING HOUSING	"Rail 16", Incl. 8 - 14"	1	
7	544887505	BEARING HOUSING	"Rail 16" USA, Incl. 8 - 14"	1	
8	506227501	SLEEVE		2	
9	503200216	SCREW IHSCFM		2	
10	506288401	SCREEN		1	
11	503252101	BALL BEARING		2	
14	503200712	SCREW IHSCFM		2	
12	506070801	SPACING SLEEVE		1	
13	506298363	SHAFT		1	
15	506340524	WHEEL GUARD ASSY	"Rail 14", Incl. 16 - 18"	1	
15	506340526	WHEEL GUARD	"Rail 16", Incl. 16 - 18"	1	
16	725533155	SCREW IHSCM		1	
17	506344602	HANDLE		1	
18	506266302	LINING		1	
19	506372721	BELT	"Rail 14""	1	
19	506372728	BELT	"Rail 16""	1	
20	506071802	PULLEY		1	
21	506254901	GEAR WHEEL ASSY	"Rail 16". Diam 41 mm. Incl. 22"	1	
21	506254903	GEAR WHEEL ASSY	"Rail 14". Diam 50 mm. Incl. 22"	1	
22	503253801	NEEDLE BEARING		1	

A K1250
K1250 Rail

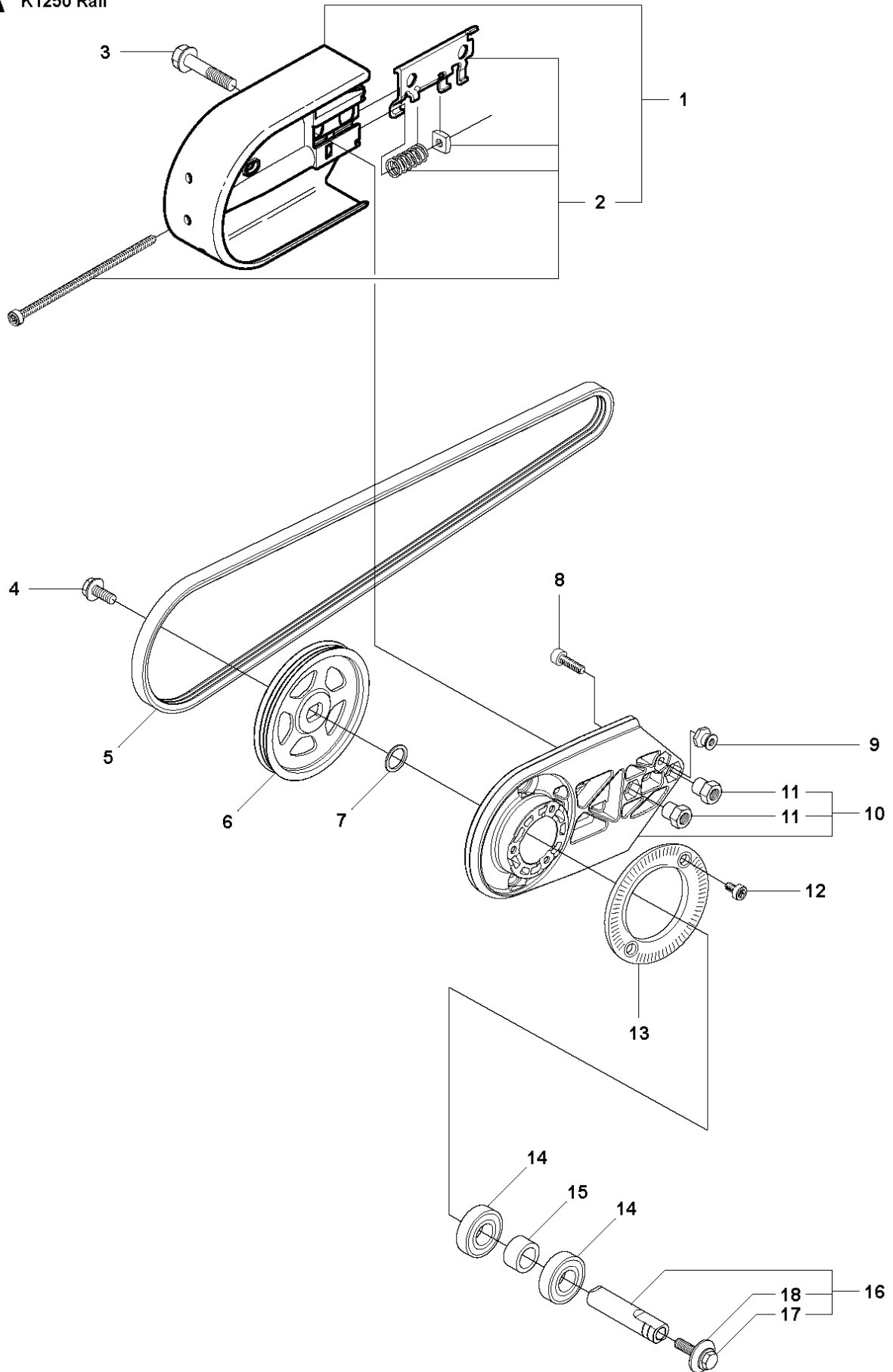

REF.	PART NO.	DESCRIPTION	REMARK	QTY.	KIT
1	506279202	BELT GUARD	Incl. 2	1	
2	506266603	BELT TENSIONER ASSY		1	
3	506284401	SCREW EHIHFM		2	
4	503200045	SCREW EHIHFM		1	
5	544976301	BELT		1	
5	506372721	BELT	"Rail 14""	1	
5	506372728	BELT	"Rail 16""	1	
6	544985001	PULLEY		1	
6	506071802	PULLEY	Rail	2	
7	503230104	WASHER		1	
8	725532955	SCREW IHSCM		1	
9	506143201	NUT CAP		1	
10	506394206	BEARING HOUSING	Incl. 11	1	
11	506287301	NUT		2	
12	503200712	SCREW IHSCFM		2	
13	506288401	SCREEN		1	
14	503252101	BALL BEARING		2	
15	506070801	SPACING SLEEVE		1	
16	506298363	SHAFT	Incl. 17, 18	1	
17	506139601	SCREW EHIHFM		1	
18	506139511	WASHER		1	

M K1250

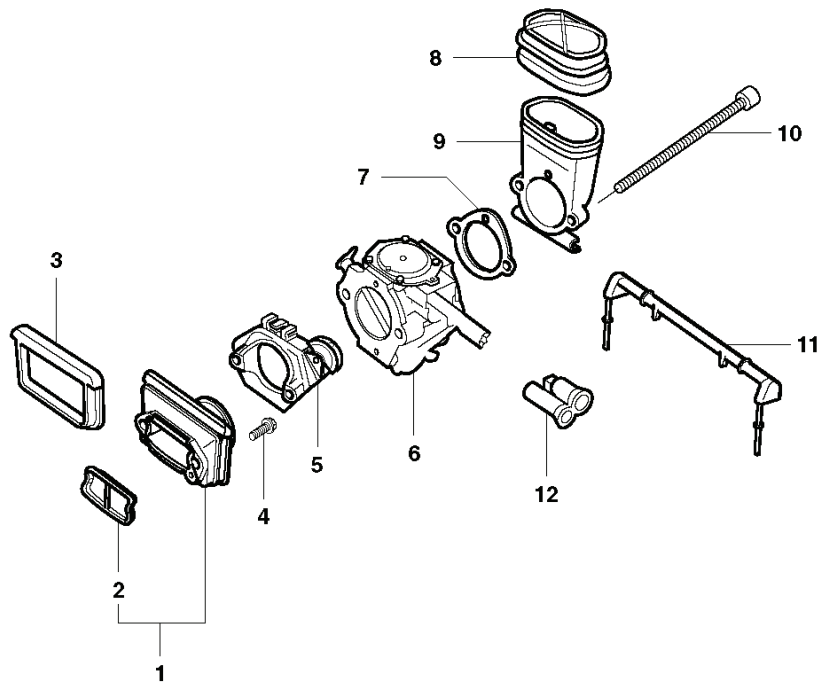

13

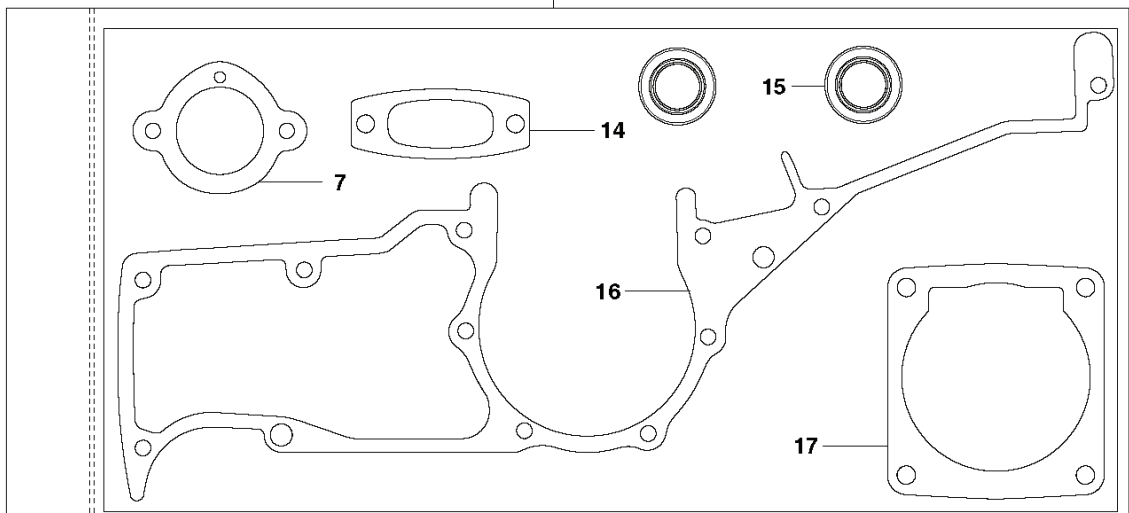

REF.	PART NO.	DESCRIPTION	REMARK	QTY.	KIT
1	506241071	INLET PIPE	Incl. 2	1	
2	506313801	INSERT		1	
3	503143701	SEALING		1	
4	503200220	SCREW IHSCFM		1	
5	506289701	FLANGE		1	
6	503281217	CARBURETTOR		1	
7	506274301	GASKET	Gasket kit 13	1	
8	506250201	BELLOWS		1	
9	506241301	INLET BEND		1	
10	503217565	SCREW IHSCFT		2	
11	506250401	SUPPORT		1	
12	506254601	CHISEL GUIDE		1	
13	506292402	GASKET KIT		1	
14	503131304	GASKET		1	
15	503260205	SEALING RING		2	
16	503134501	CRANKCASE		1	
17	503134601	GASKET		1	

N K1250
K1250 Rail

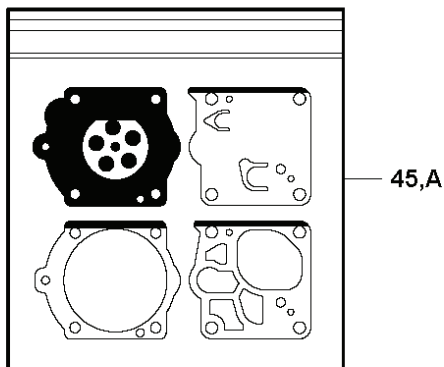
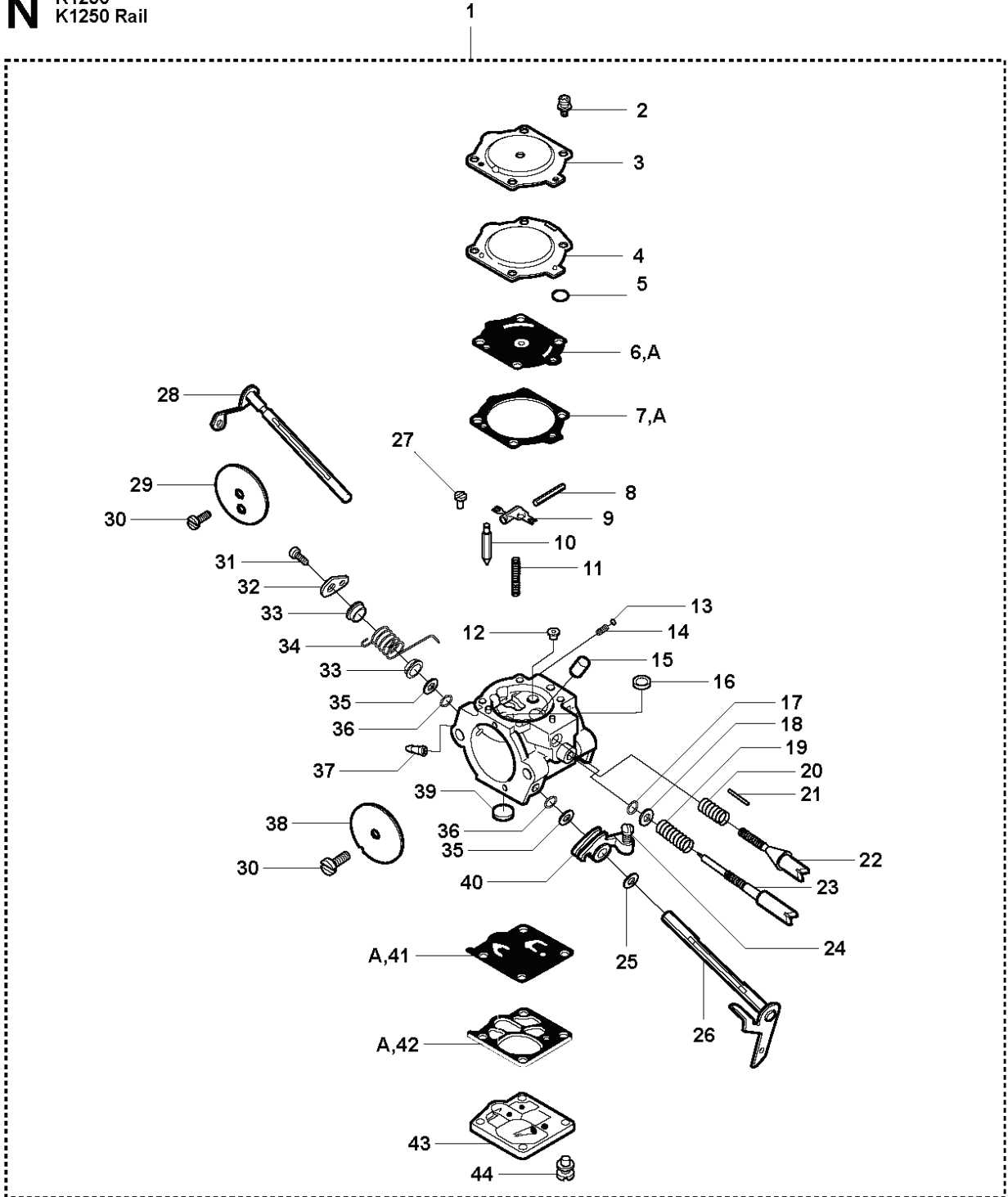

REF.	PART NO.	DESCRIPTION	REMARK	QTY.	KIT
1	503281217	CARBURETTOR		1	
2	537003101	SCREW		1	
3	501692801	COVER		1	
4	537002901	COVER		1	
5	537002801	RING		1	
6	503632801	DIAPHRAGM ASSY	Kit 45	1	
7	501467501	GASKET		1	
8	505316731	PIN		1	
9	505316734	LEVER		1	
10	503563401	NEEDLE VALVE		1	
11	505316723	SPRING		1	
12	537153401	JET		1	
13	501468501	BALL		1	
14	501468401	SPRING		1	
15	503976601	NOZZLE ASSY		1	
16	503574201	PLUG		1	
17	503595501	O-RING		1	
18	503597201	WASHER		1	
19	505316737	SPRING		1	
20	503633101	SPRING		1	
21	503526001	PIN THROTTLE STOP		1	
22	503632901	SCREW IDLE SPEED		1	
23	503633201	NEEDLE IDLE SPEED		1	
24	503596501	SCREW		1	
25	506028301	WASHER		1	
26	503595901	SHAFT ASSY		1	
27	505316717	SCREW		1	
28	537003001	SHAFT ASSY		1	
29	503525801	VALVE CHOKE		1	
30	530035015	SCREW		2	
31	503192201	SCREW PAN HD(M2.5X5)		1	
32	503595601	LEVER		1	
33	502103101	BUSHING		2	
34	503525901	SPRING THROTT RETURN		1	
35	505316748	WASHER		2	
36	503564501	SEAL		2	
37	503598401	FITTING		1	
38	503632401	VALVE THROTTLE		1	
39	501666101	SCREEN		1	
40	503595701	LEVER		1	
41	503117301	DIAPHRAGM PUMP	Kit 45	1	
42	503117201	GASKET	Kit 45	1	
43	503595801	COVER		1	
44	503117501	SCREW		1	
45	503597402	GASKET KIT		1	

F K1250
K1250 Rail

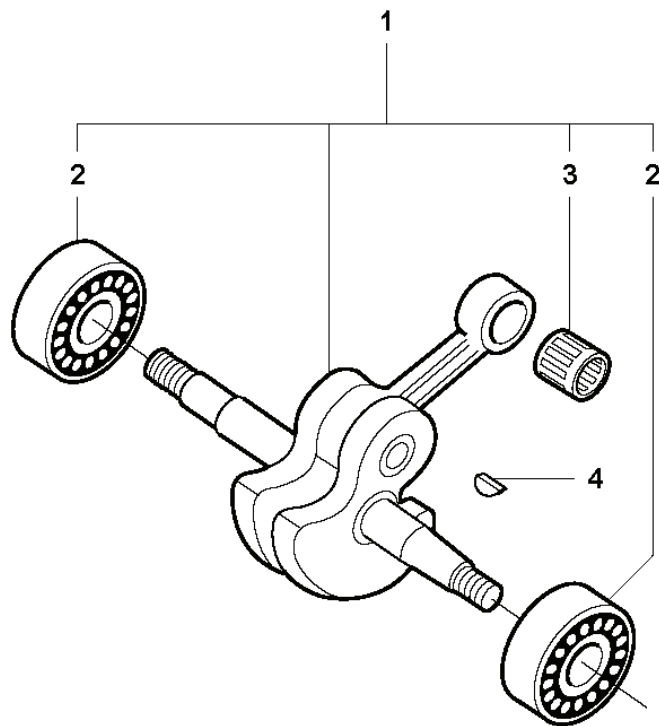

REF.	PART NO.	DESCRIPTION	REMARK	QTY.	KIT
1	503142073	CRANKSHAFT ASSY	Incl. 2, 3	1	
2	503250002	BALL BEARING		2	
3	503132901	NEEDLE HOLDER		1	
4	735880600	WOODRUFF KEY		1	

D K1250

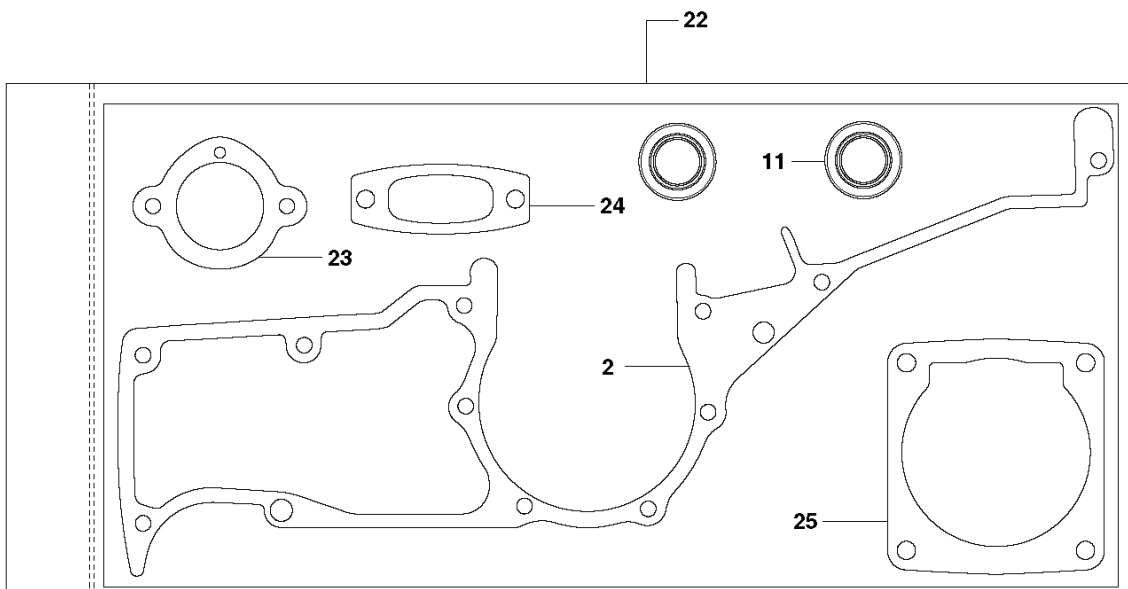
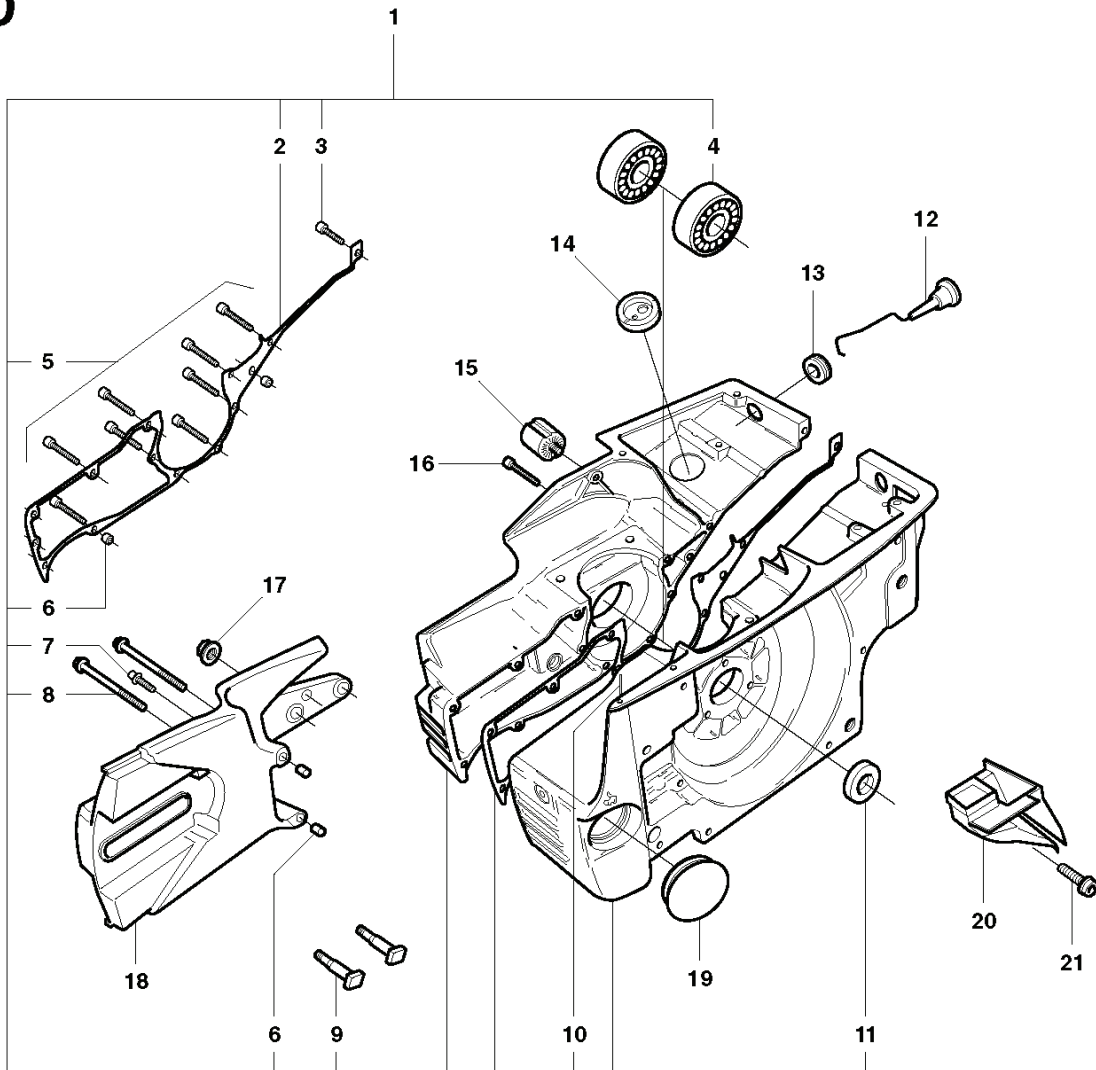

REF.	PART NO.	DESCRIPTION	REMARK	QTY.	KIT
1	501892572	CRANKCASE	Incl. 2-11	1	
2	503134501	CRANKCASE	Gasket kit 22	1	
3	725533155	SCREW IHSCM		3	
4	503250002	BALL BEARING		2	
5	725533955	SCREW IHSCM		9	
6	501270801	GUIDE BUSHING		4	
7	503200220	SCREW IHSCFM		1	
8	503200265	SCREW IHSCFM		2	
9	501815701	BAR BOLT		2	
10	721420600	SPRING PIN		1	
11	503260205	SEALING RING	Gasket kit 22	2	
12	506254301	CHOKE CONTROL		1	
13	503145402	GROMMET		1	
14	503132001	GROMMET		1	
15	501269704	ANTIVIBRATION ELEMENT		1	
16	725537055	SCREW IHSCM		1	
17	503220001	HEXAGON NUT		1	
18	506241402	CUTTER ARM		1	
19	506269702	PLUG		1	
20	506237001	AIR NOZZLE		1	
21	503200212	SCREW IHSCFM		1	
22	506292402	GASKET KIT		1	
23	506274301	GASKET		1	
24	503131304	GASKET		1	
25	503134601	GASKET		1	

E K1250

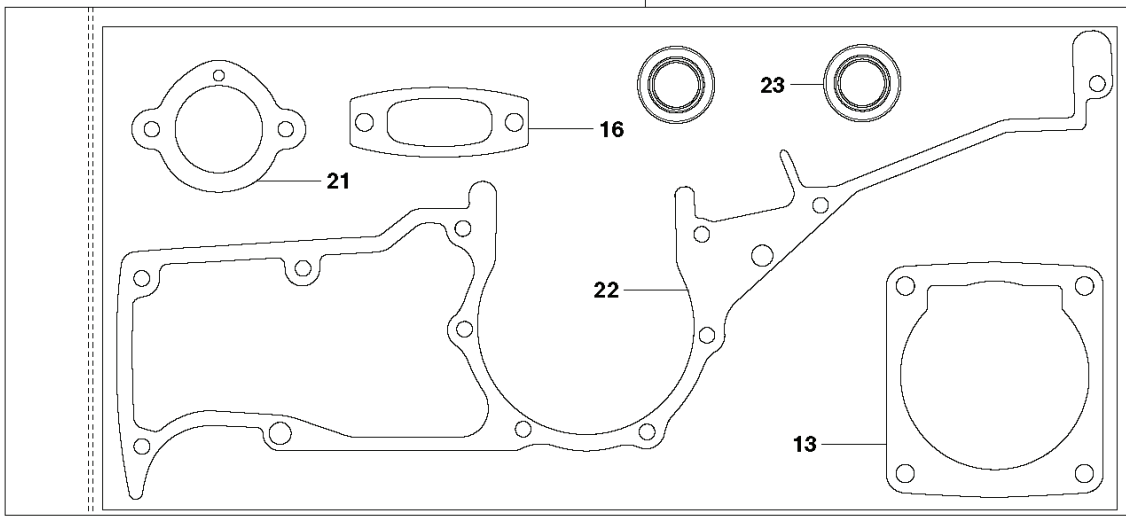
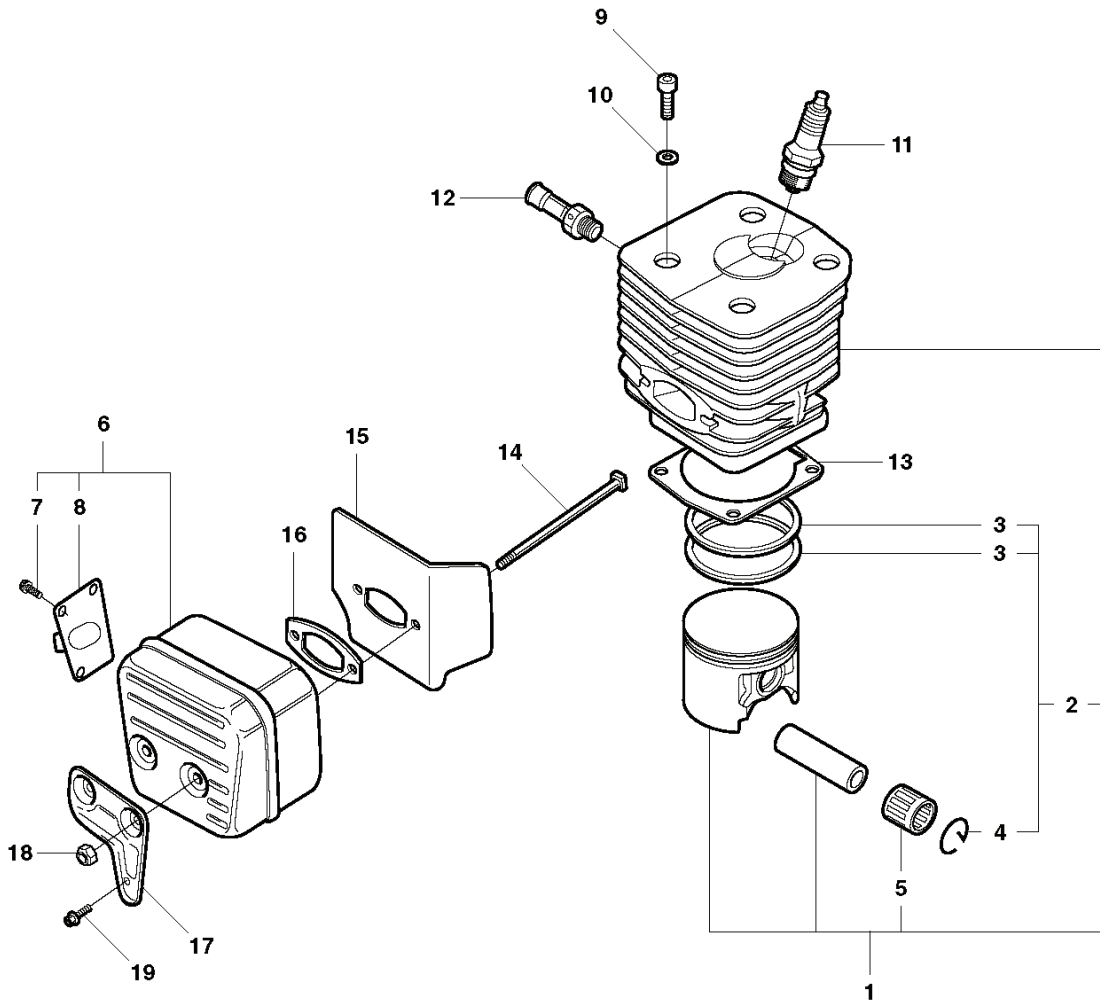

REF.	PART NO.	DESCRIPTION	REMARK	QTY.	KIT
1	506294271	CYLINDER ASSY	Incl. 2, 3, 4, 5	1	
2	501894103	PISTON ASSY	Incl. 3, 4,	1	
3	503289026	PISTON RING		2	
4	737441300	CIRCLIP		2	
5	503132901	NEEDLE HOLDER		1	
6	503130004	MUFFLER ASSY	Incl. 7, 8	1	
7	729534001	SCREW CCRPANT		4	
8	506274901	EXHAUST DUCT		1	
9	503216025	SCREW		4	
10	503230005	WASHER		4	
11	503235111	SPARK PLUG	RCJ 6Y	1	
12	503665601	DECOMPRESSION VALVE		1	
13	503134601	GASKET	Gasket kit 20	1	
14	503216401	SCREW		2	
15	506341401	COOLING AIR CONDUCTOR		1	
16	503131304	GASKET	Gasket kit 20	1	
17	506278701	SUPPORT		1	
18	503222007	LOCK NUT		2	
19	725536855	SCREW IHSCM		1	
20	506292402	GASKET KIT		1	
21	506274301	GASKET		1	
22	503134501	CRANKCASE		1	
23	503260205	SEALING RING		2	

H K1250
K1250 Rail

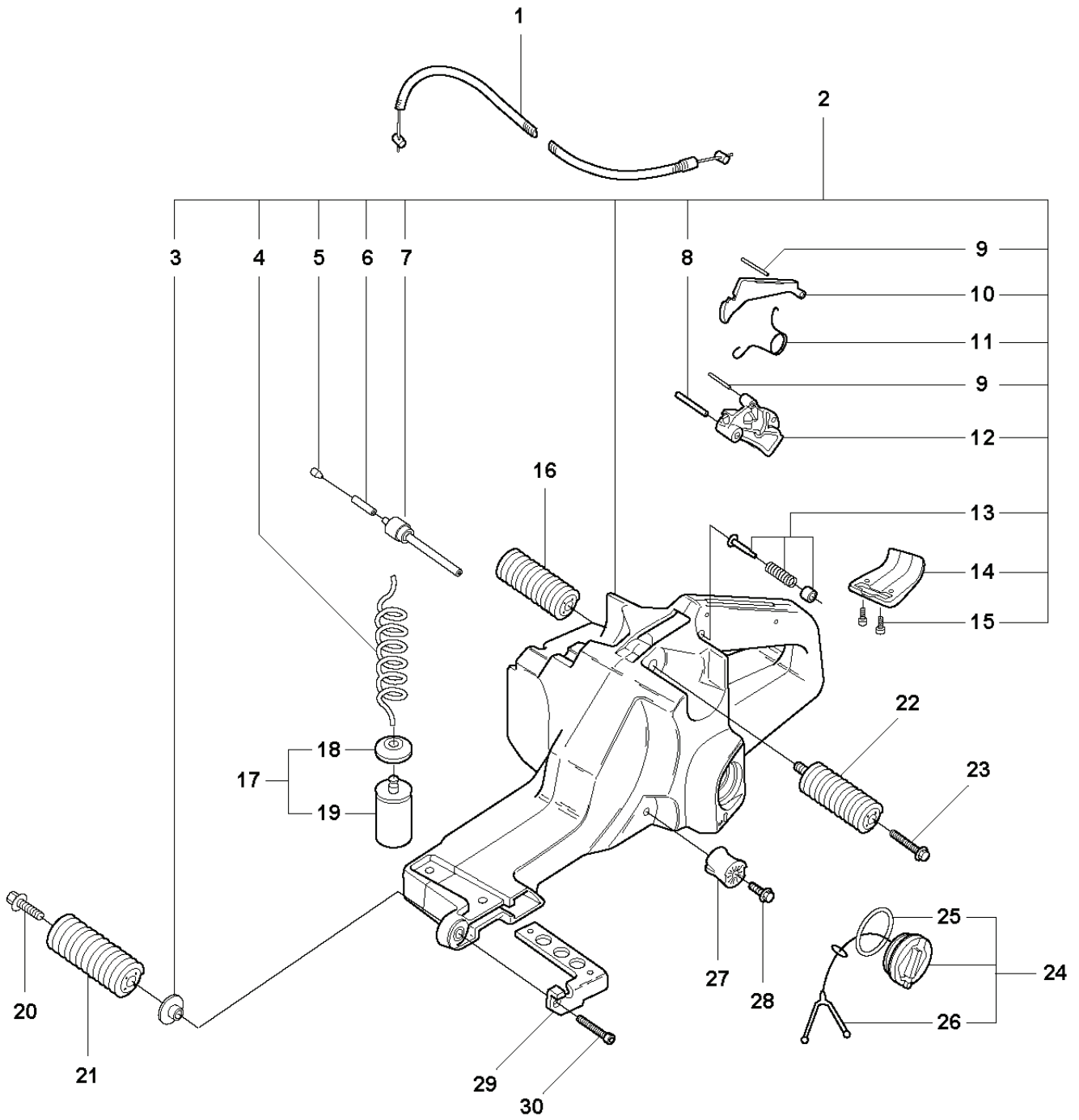

REF.	PART NO.	DESCRIPTION	REMARK	QTY.	KIT
1	506289801	THROTTLE CABLE ASSY		1	
2	503142106	TANK UNIT ASSY		1	
3	503140801	BUSHING		1	
4	503577602	FUEL HOSE		1	
5	504357201	PLUG		1	
6	501768304	FUEL HOSE		1	
7	506293901	TANK VENT		1	
8	720127806	PARALLEL PIN		1	
9	720124020	PARALLEL PIN		1	
10	503131601	THROTTLE LOCKOUT		1	
11	503131801	SPRING		1	
12	503133601	THROTTLE CONTROL ASSY		1	
13	503142301	PIN		1	
14	506233401	SUPPORT		1	
15	503214516	SCREW CRCSFT		2	
16	503132601	ANTIVIBRATION ELEMENT		1	
17	506264111	FUEL FILTER		1	
18	506271101	HOSE CLAMP		1	
19	506264101	FUEL FILTER		1	
20	503200225	SCREW IHSCFM		1	
21	503132701	ANTIVIBRATION ELEMENT		1	
22	503132501	ANTIVIBRATION ELEMENT		1	
23	725536855	SCREW IHSCM		2	
24	506255903	TANK CAP ASSY		1	
25	506292101	GASKET		1	
26	503578901	HOLDER		1	
27	501814701	ANTIVIBRATION ELEMENT		1	
28	503200212	SCREW IHSCFM		1	
29	503140501	BRACKET		1	
30	503200230	SCREW IHSCFM		1	

G K1250
K1250 Rail

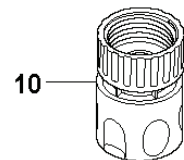
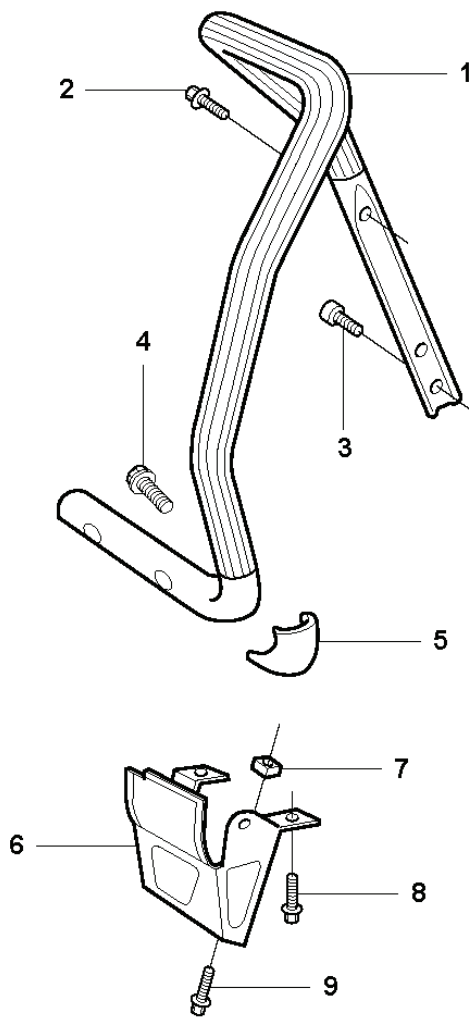

REF.	PART NO.	DESCRIPTION	REMARK	QTY.	KIT
1	506255302	HANDLE		1	
2	503200210	SCREW IHSCFM		1	
3	503210525	SCREW IHST		2	
4	503210632	SCREW IHST		4	
5	506149001	SUPPORT		1	
6	506250101	GROUND SUPPORT		1	
7	503226504	SQUARE NUT		2	
8	725537055	SCREW IHSCM		2	
9	503200312	SCREW IHSCFM		2	
10	503266002	COUPLER		1	

S K1250
K1250 Rail

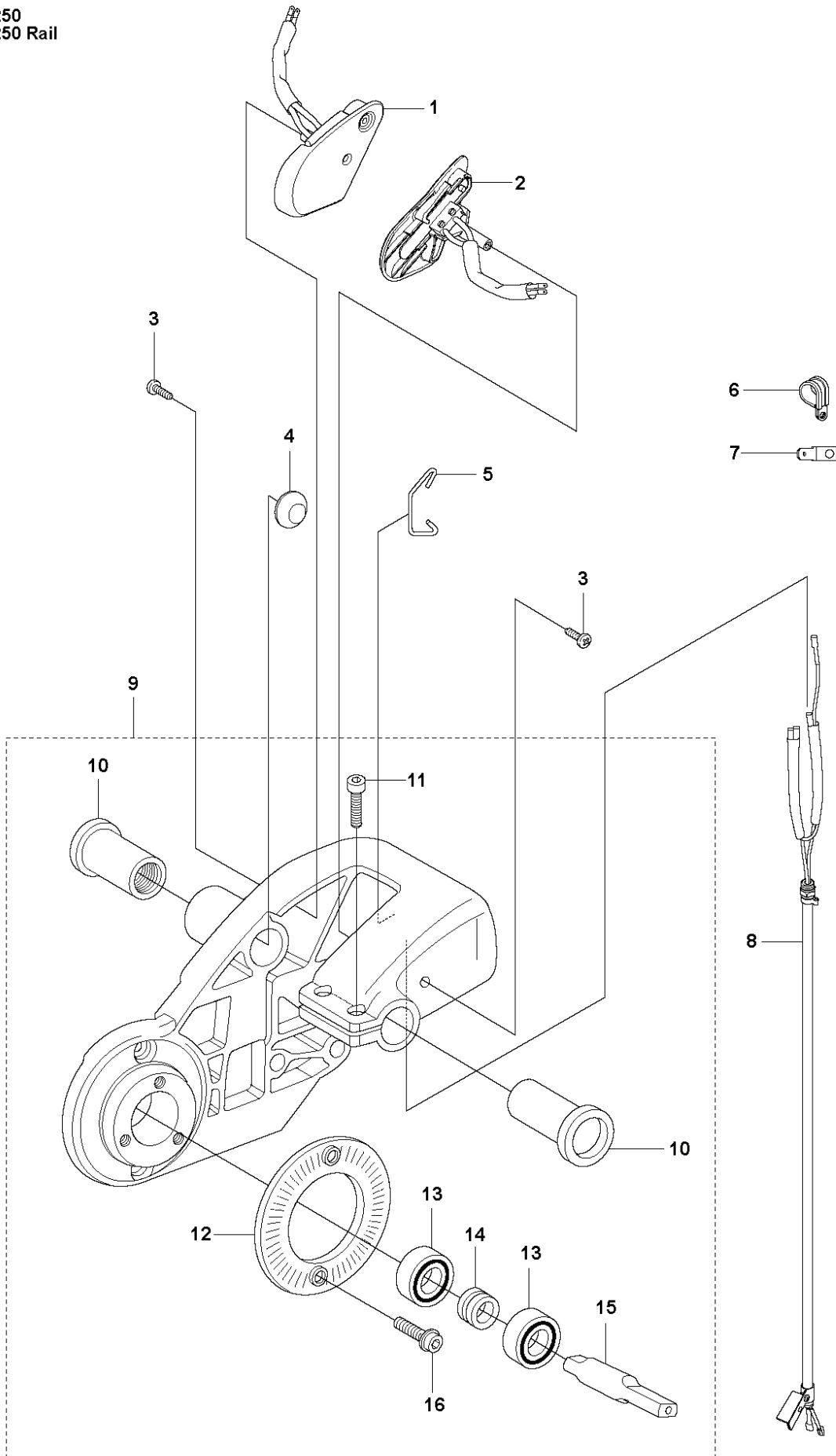

REF.	PART NO.	DESCRIPTION	REMARK	QTY.	KIT
1	506359104	STOP SWITCH	RH	1	
2	506359103	STOP SWITCH	LH	1	
3	729532771	SCREW CRPANT		2	
4	506359601	SPACING BLOCK		1	
6	506358001	BRACKET		1	
7	535039401	CONNECTION		1	
8	506359001	WIRING		1	
9	544887502	BEARING HOUSING	"K1250 Rail 14". Stop, Incl. 10 - 16"	1	
9	544887504	BEARING HOUSING	"K1250 Rail 16". Stop, Incl. 10 - 16"	1	
10	506227501	SLEEVE		2	
11	503200216	SCREW IHSCFM		2	
12	506288401	SCREEN		1	
13	503252101	BALL BEARING		2	
14	506070801	SPACING SLEEVE		1	
15	506298363	SHAFT		1	
16	503200712	SCREW IHSCFM		2	

K K1250
K1250 Rail

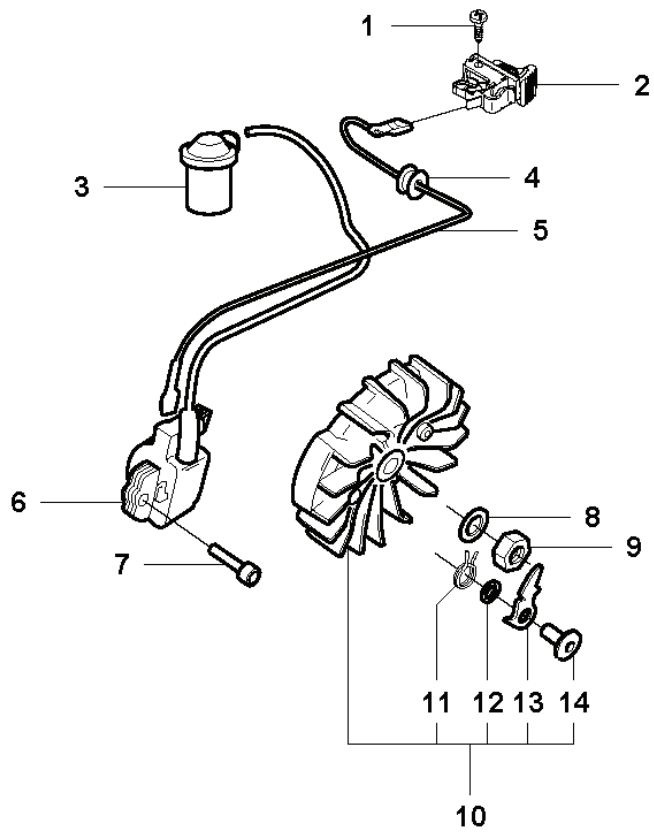

REF.	PART NO.	DESCRIPTION	REMARK	QTY.	KIT
1	503219008	SCREW CCRPANM		1	
2	506318602	STOP SWITCH		1	
3	501485402	SPARK PLUG CAP		1	
4	503132401	CABLE GROMMET		1	
5	501839803	CABLE		1	
6	544018801	IGNITION SYSTEM		1	
7	503202520	SCREW IHSCM		1	
8	735117350	SPRING WASHER		1	
9	503221003	HEXAGON NUT		1	
10	501895003	FLYWHEEL ASSY	Incl. 2-5	1	
11	501634801	SPRING		2	
12	503230042	WASHER		2	
13	501673203	PAWL		2	
14	501819901	SCREW		2	

T K1250
K1250 Rail

1

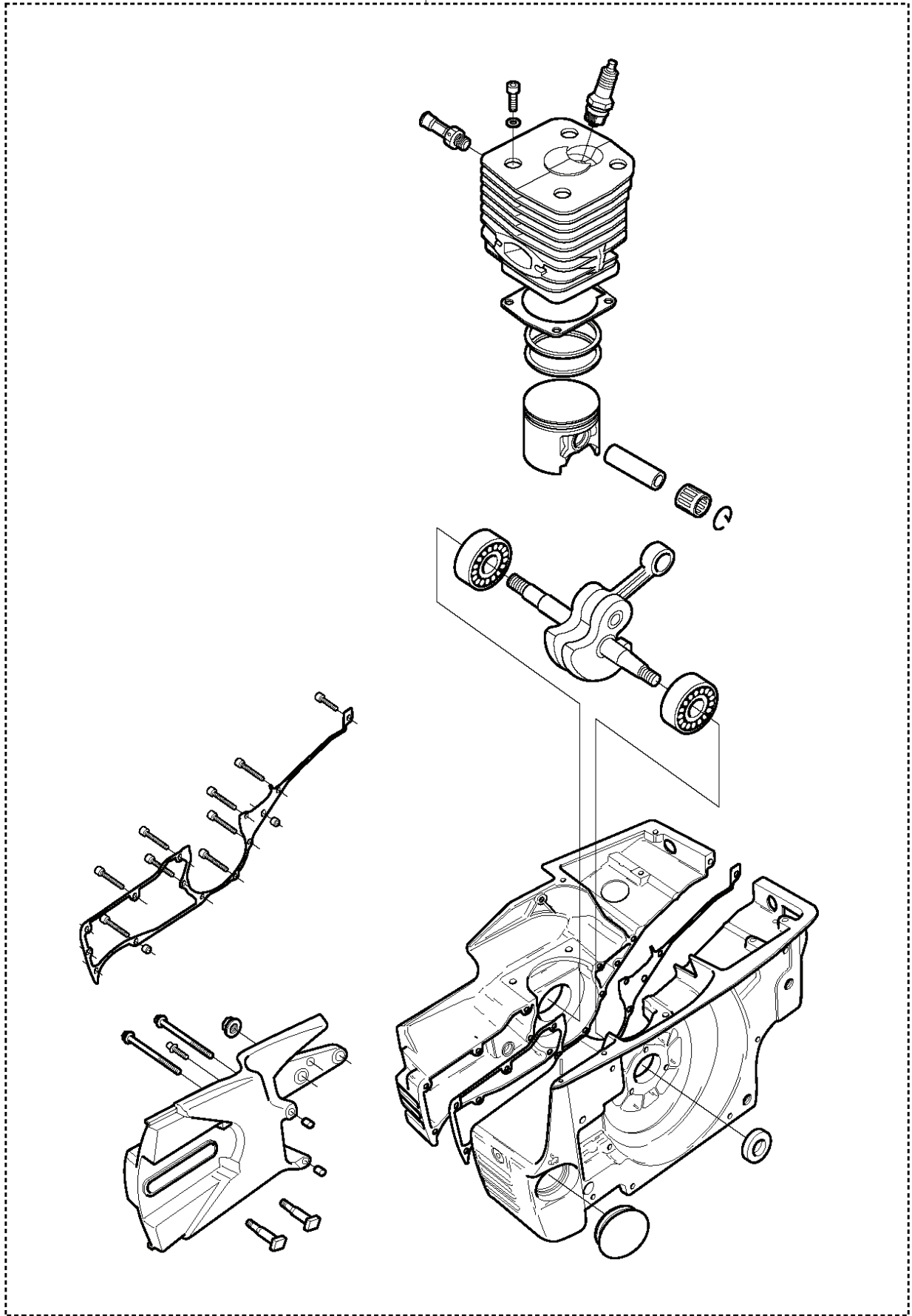

REF.	PART NO.	DESCRIPTION	REMARK	QTY.	KIT
1	544904403	CRANKCASE ASSY		1	

J K1250

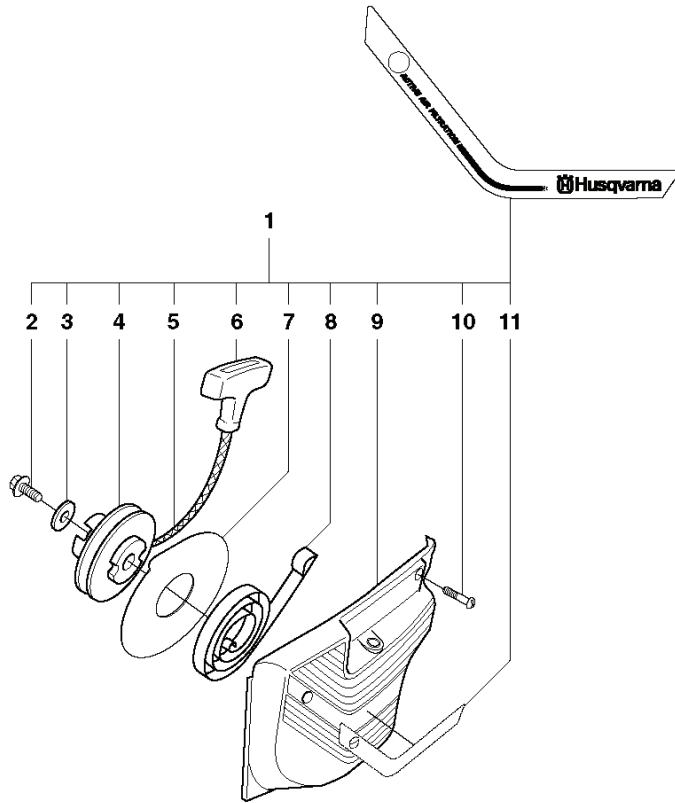
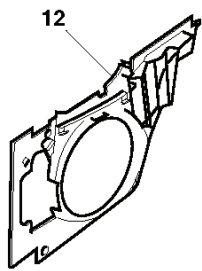

REF.	PART NO.	DESCRIPTION	REMARK	QTY.	KIT
1	506275502	STARTER	Incl. 2-11	1	
2	503210616	SCREW IHST		1	
3	503234302	WASHER		1	
4	501896701	STARTER PULLEY		1	
5	506335625	STARTER ROPE		1	
6	503127901	STARTER HANDLE		1	
7	503743601	DISC		1	
8	503135001	RECOIL SPRING		1	
9	506255802	STARTER COVER		1	
10	503203425	SCREW CCRPANMO		4	
11	544873501	LABEL		1	
12	501895902	AIR CONDUCTOR	K1250 A	1	
12	501895903	AIR CONDUCTOR	K1250 Rail	1	

Q K1250
K1250 Rail

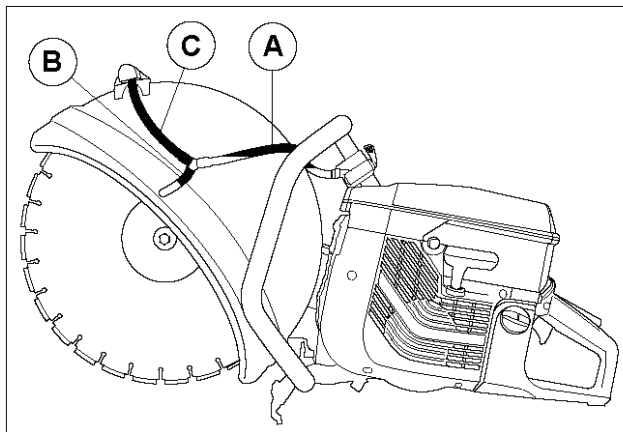
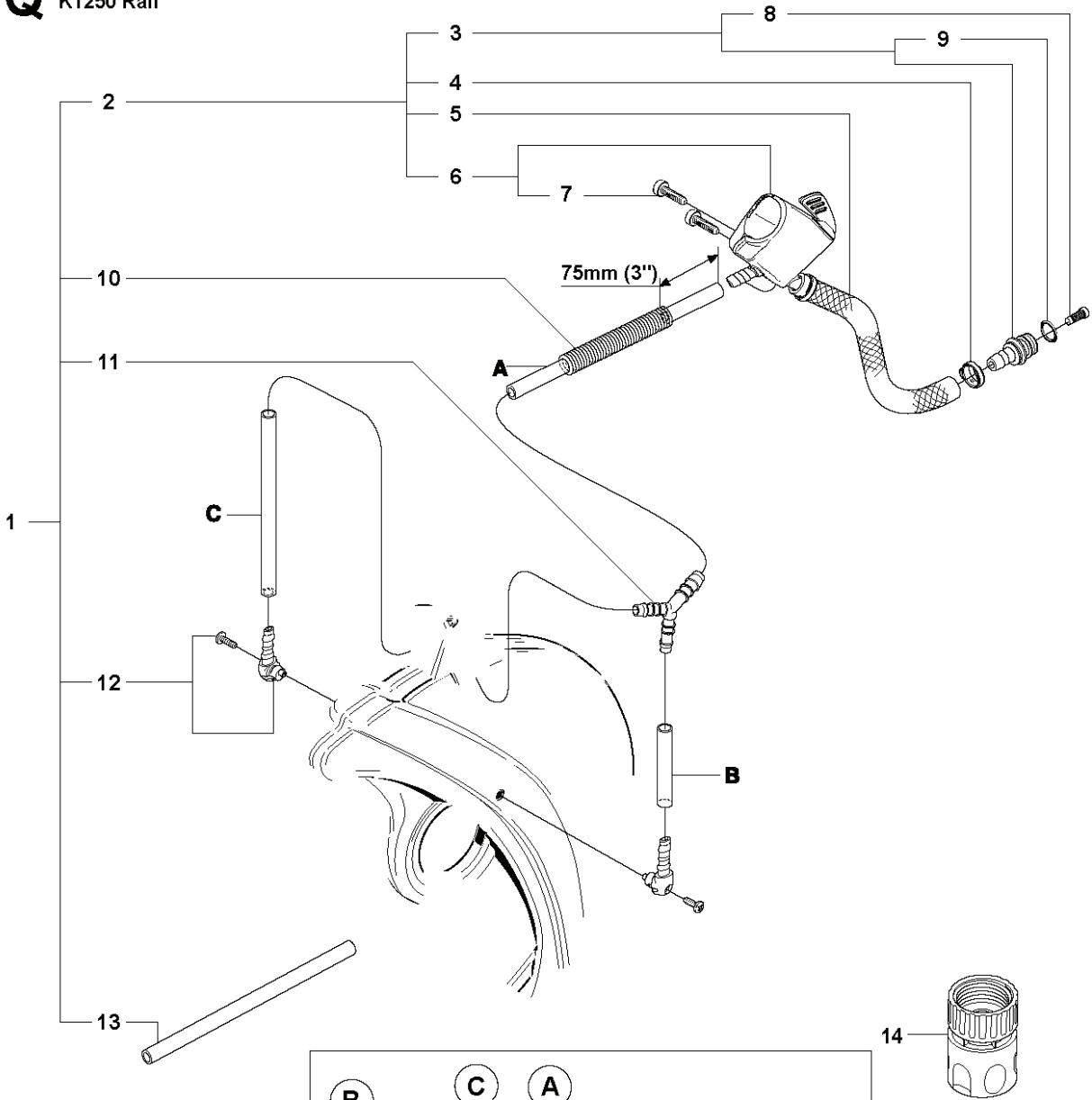

Product		A (mm)	B (mm)	C (mm)
K1250A	14"	280	45	280
	16"	270	45	360

REF.	PART NO.	DESCRIPTION	REMARK	QTY.	KIT
1	544003103	HOSE KIT	Incl. 2, 10-13	1	
2	506329021	VALVE ASSY	Incl. 3-6	1	
3	506295702	NIPPLE	Incl. 8	1	
4	506095602	HOSE CLAMP		2	
5	506097502	HOSE	L=230mm	1	
6	506317731	VALVE ASSY	Incl. 7	1	
7	503210619	SCREW IHSCT		2	
8	506298801	FILTER		1	
9	503263021	O-RING		1	
10	506352701	PROTECTIVE SPRING		1	
11	506328701	Y-TUBE		1	
12	506295601	NIPPLE		2	
13	506095824	HOSE	L=800mm	1	
14	503266002	COUPLER		1	

B K1250
K1250 Rail

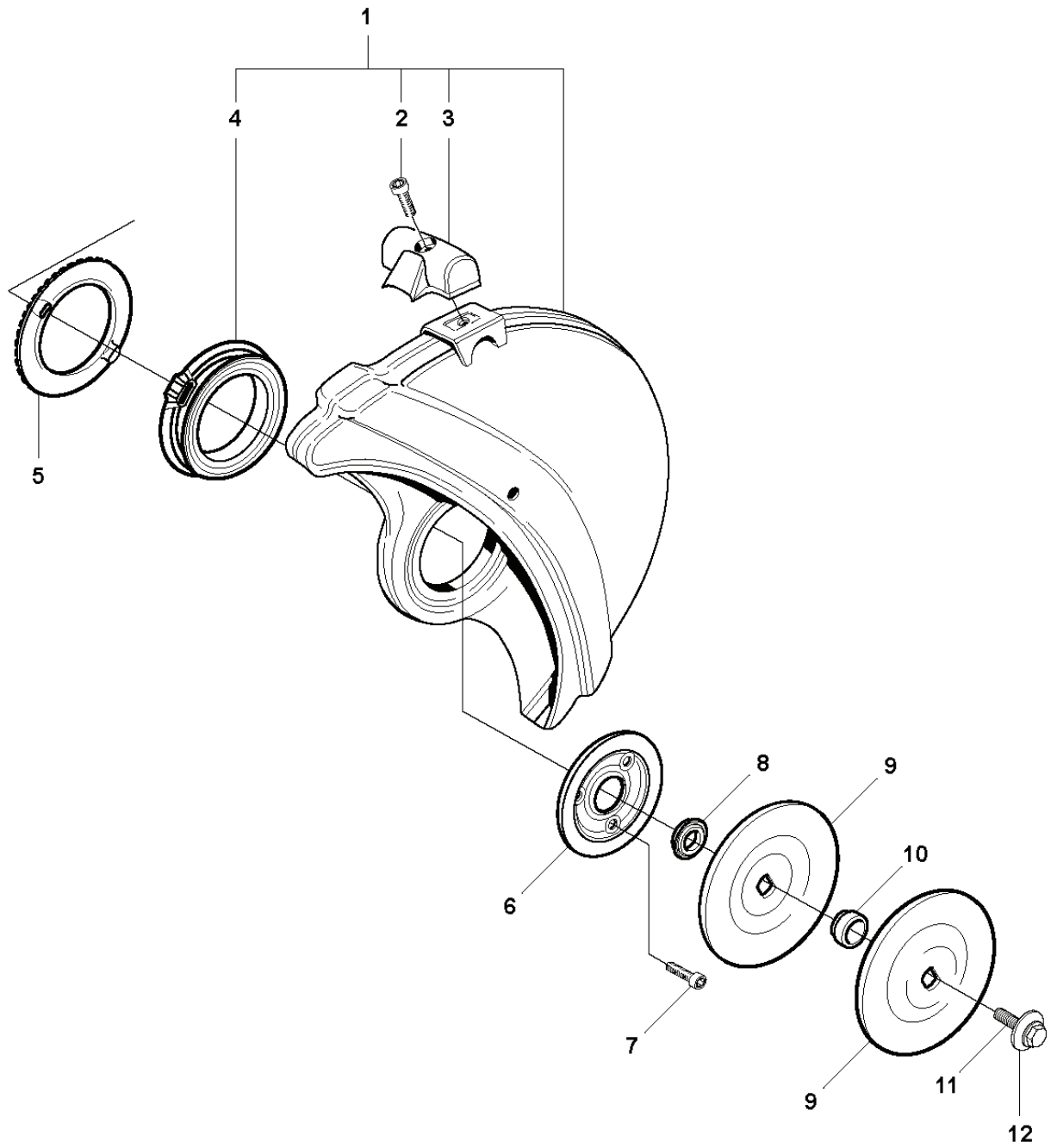

REF.	PART NO.	DESCRIPTION	REMARK	QTY.	KIT
1	506340504	WHEEL GUARD	"14"	1	
1	506340506	GUARD	"16"	1	
1	506340524	WHEEL GUARD ASSY	"Rail 14"	1	
1	506340526	WHEEL GUARD	"Rail 16"	1	
2	725533155	SCREW IHSCM		1	
3	506344602	HANDLE		1	
4	506266302	LINING		1	
5	506266401	SCREEN		1	
6	506266501	FLANGE		1	
7	725532955	SCREW IHSCM		3	
8	506324801	SUPPORT FLANGE	K1250 A	1	
8	506267101	SUPPORT FLANGE	K1250 Rail	1	
9	506028701	FLANGE WASHER	Diam 105 mm	1	
9	506070901	FLANGE WASHER	Diam 119 mm	1	
10	506379620	KIT	Diam 20 mm	1	
10	506379622	BUSHING	Diam 22,2 mm	1	
10	506379625	KIT	Diam 25 mm	1	
10	506028830	BUSHING	Diam 30,5 mm	1	
11	506139511	WASHER		1	
12	506139601	SCREW EHIHFM		1	
13	506284112	LABEL	"14". Diam 20mm"	1	
13	506284111	LABEL	"14". Diam 22,2 mm"	1	
13	506284114	LABEL	"14". Diam 25,4mm"	1	
13	506284122	LABEL	"16". Diam 20mm"	1	
13	506284121	LABEL	"16". Diam 22,2mm"	1	
13	506284124	LABEL	"16". Diam 25,4mm"	1	

P K1250
Accessories
Zubehöre
Accessoires
Accesorios
Tillbehör

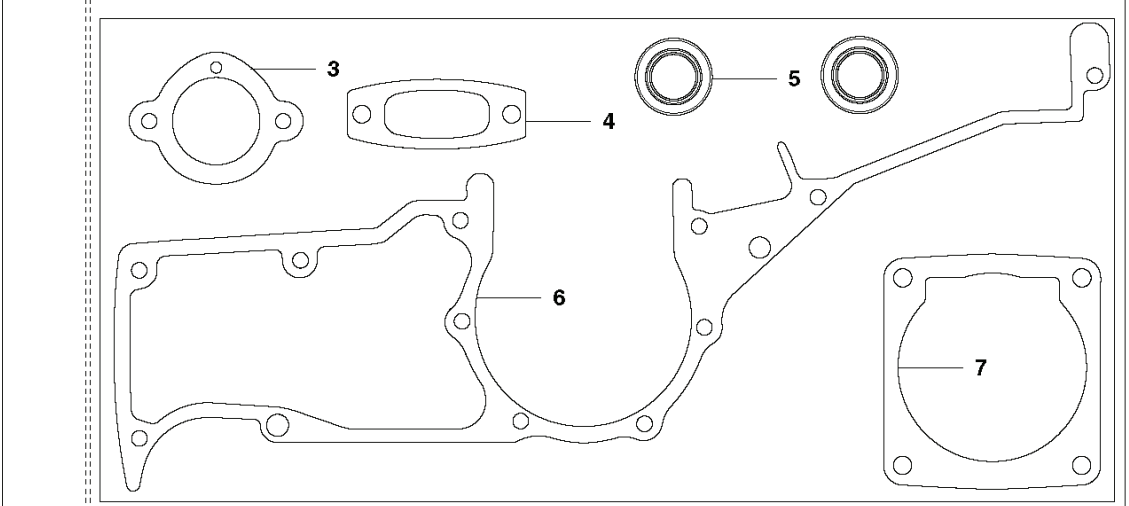
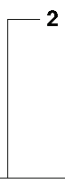
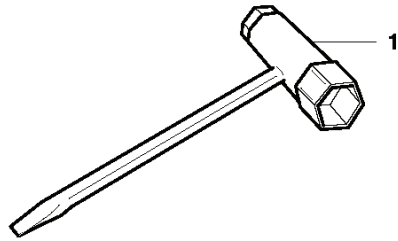

REF.	PART NO.	DESCRIPTION	REMARK	QTY.	KIT
1	501691702	COMBINATION WRENCH		1	
2	506292402	GASKET KIT		1	
3	506274301	GASKET		1	
4	503131304	GASKET		1	
5	503260205	SEALING RING		2	
6	503134501	CRANKCASE		1	
7	503134601	GASKET		1	